

Job Name: 24-4112 - Ohio River Service Area Rehab
 Job Location: Louisville, KY 40222
 Contractor: TRC, LLC

Plant: Beaver Dam, KY
 1/22/2026 5:59:09 AM

Tech: K. Cardwell
 PC: A. Wells



Structure ID: 960

P1 MH048BA24

MH BASE T/n

P6) 24" - CASTING HEIGHT - 7"	0 lb
P5) 24" - GRADE RING F/F - 4"	270 lb
P4) 48" - ECC CONE w/ 24" HOLE F/G - 36"	3000 lb
P3) 48" - MH RISER T/G - 36"	2515 lb
P2) 48" - MH RISER T/G - 60"	4192 lb
P1) 48" - MH BASE T/n - 24"	2911 lb
1) JOINT WRAP PRIMER - CONSEAL CS-75 (1 gal.)	0 lb
1) JOINT WRAP - 0.065"x6"x50" CONSEAL CS212	0 lb
1) 48" - SAN. INV. CHANNEL - FULL HEIGHT	1440 lb
3) 48" - Conseal CS-102 1.00" (Double)	0 lb
2) PSX - 12-08 NYLO	16 lb
12) MH Step ML-10-TDS-NCR - 10"	0 lb
Structure Total:	14343 lb

Structure Notes:
 STATION: 0+11.88 CARDINAL HARBOUR 2
 1. PER MSD & ASTM C-478 SPECS
 2. CONCRETE: 5,000 PSI AT 28 DAYS
 3. REINFORCEMENT: PER ASTM A615
 4. INVERT CHANNEL REQUIRED
 5. 7" CASTING SUPPLIED BY OTHERS
 6. STEPS AT 235 DEGREES

Rim: 450.3' Rim to Invert: 13.83' Slack: 1.96" Sump: 3" Step Position: 235°

Position	Elev	Angle	Ext. (cw)	Pipe	Pipe OD	Connector	Hole	Horz Size	Up ()	Offset
Invert 1	436.47'	0°	0"	8" PVC SDR35	8.5"	PSX 12-08 NYLO	12"	12.129"	1"	0"
Invert 2	436.57'	110°	55.676"	8" PVC SDR35	8.5"	PSX 12-08 NYLO	12"	12.129"	2.2"	0"
Invert 3										
Invert 4										
Invert 5										
Invert 6										
Invert 7										
Invert 8										

RIGHT-SIDE UP VIEW (int. dimensions)

UPSIDE-DOWN VIEW (int. dimensions)

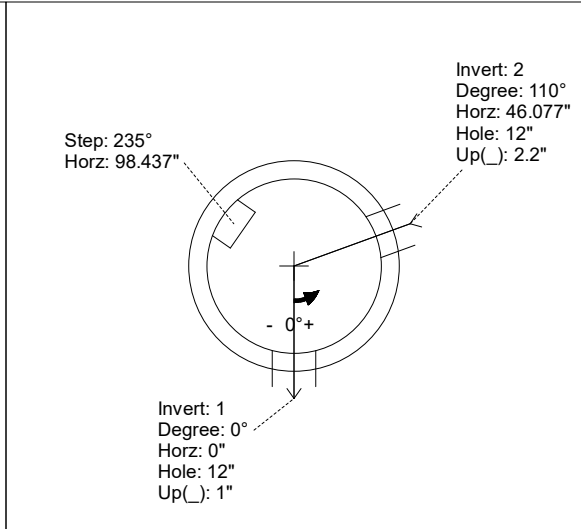
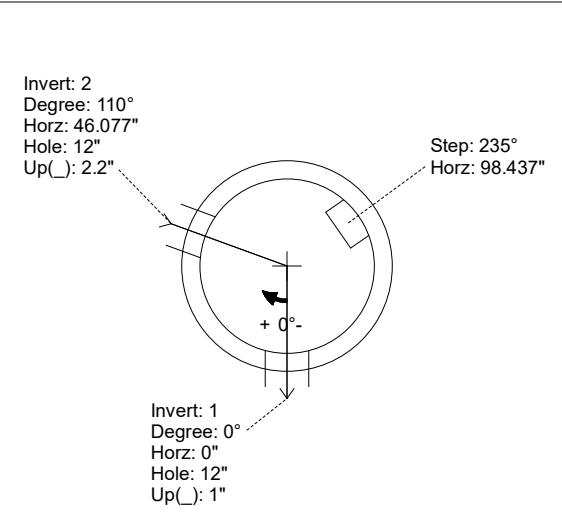
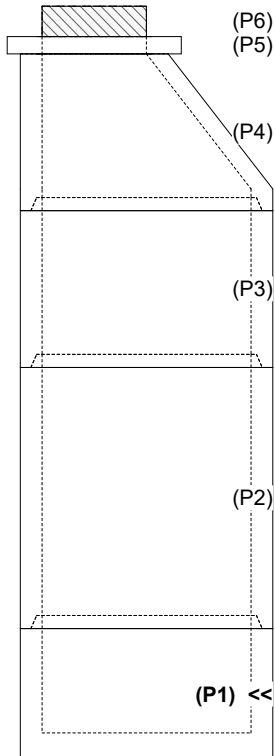

INSIDE WALL DIMENSIONS

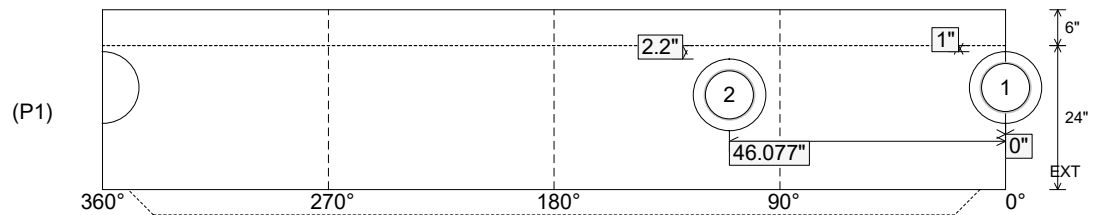

Coating (Int):
 Coating (Ext):

Seam Up: Tongue
 Seam Dn: n/a

Wall Thickness: 5"
 Floor Height: 6"

Height (Int): 24"
 Height (Ext): 30"

Weight (Net): 2911 lb
 Volume (Net): 0.74cu.yd

Job Name: 24-4112 - Ohio River Service Area Rehab
 Job Location: Louisville, KY 40222
 Contractor: TRC, LLC

Plant: Beaver Dam, KY
 1/22/2026 5:59:09 AM

Tech: K. Cardwell
 PC: A. Wells



Structure ID: 960

P1 MH048BA24

MH BASE T/n

P6) 24" - CASTING HEIGHT - 7"	0 lb
P5) 24" - GRADE RING F/F - 4"	270 lb
P4) 48" - ECC CONE w/ 24" HOLE F/G - 36"	3000 lb
P3) 48" - MH RISER T/G - 36"	2515 lb
P2) 48" - MH RISER T/G - 60"	4192 lb
P1) 48" - MH BASE T/n - 24"	2911 lb
1) JOINT WRAP PRIMER - CONSEAL CS-75 (1 gal.)	0 lb
1) JOINT WRAP - 0.065"x6"x50" CONSEAL CS212	0 lb
1) 48" - SAN. INV. CHANNEL - FULL HEIGHT	1440 lb
3) 48" - Conseal CS-102 1.00" (Double)	0 lb
2) PSX - 12-08 NYLO	16 lb
12) MH Step ML-10-TDS-NCR - 10"	0 lb
Structure Total:	14343 lb

Structure Notes:
 STATION: 0+11.88 CARDINAL HARBOUR 2
 1. PER MSD & ASTM C-478 SPECS
 2. CONCRETE: 5,000 PSI AT 28 DAYS
 3. REINFORCEMENT: PER ASTM A615
 4. INVERT CHANNEL REQUIRED
 5. 7" CASTING SUPPLIED BY OTHERS
 6. STEPS AT 235 DEGREES

Rim: 450.3' Rim to Invert: 13.83' Slack: 1.96" Sump: 3" Step Position: 235°

Position	Elev	Angle	Ext. (cw)	Pipe	Pipe OD	Connector	Hole	Horz Size	Up ()	Offset
Invert 1	436.47'	0°	0"	8" PVC SDR35	8.5"	PSX 12-08 NYLO	12"	12.129"	1"	0"
Invert 2	436.57'	110°	55.676"	8" PVC SDR35	8.5"	PSX 12-08 NYLO	12"	12.129"	2.2"	0"
Invert 3										
Invert 4										
Invert 5										
Invert 6										
Invert 7										
Invert 8										

RIGHT-SIDE UP VIEW (int. dimensions)

UPSIDE-DOWN VIEW (int. dimenions)

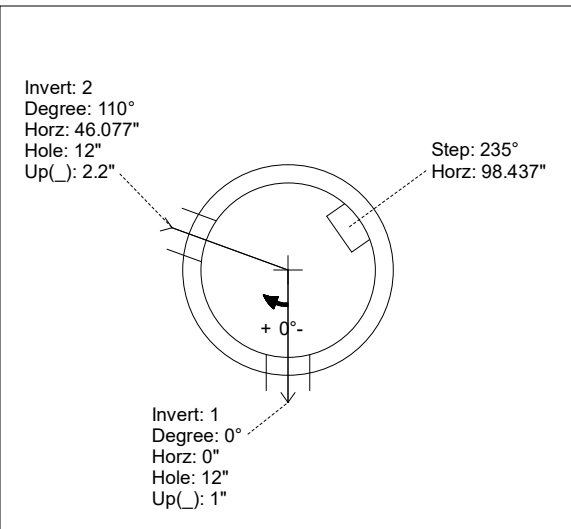
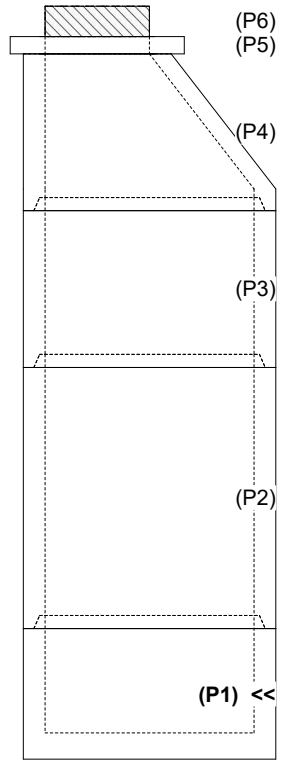

INVERT CHANNEL
DRAWING

INSIDE WALL DIMENSIONS

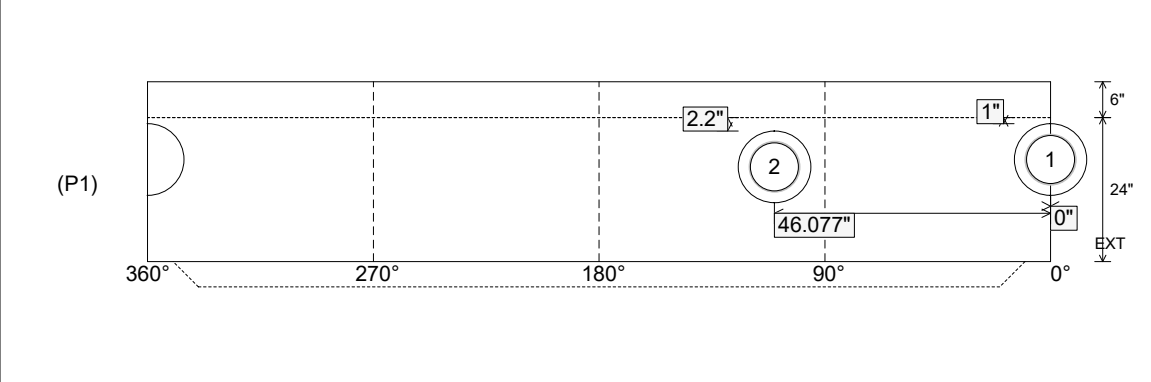

Coating (Int): Coating (Ext):	Seam Up: Tongue Seam Dn: n/a	Wall Thickness: 5" Floor Height: 6"	Height (Int): 24" Height (Ext): 30"	Weight (Net): 2911 lb Volume (Net): 0.74cu.yd
----------------------------------	---------------------------------	--	--	--