

Job Name: 24-3925 Heritage Meadows
 Job Location: Elizabethtown, KY
 Contractor: Phillips Bros. Construction, LLC

Plant: Beaver Dam

Tech: J. Horsley

10/15/2025 12:30:34 PM

PC: T. Ryan



Structure ID: ARV 04 (48in) 6in FM 35+26

P2 MH048DHVF

MH DH RISER Custom Ht T/F

- P4) 24" - CASTING HEIGHT - 7"
- P3) 48" - MH FLAT TOP w/ 24" ECC Hole F/G - 12"
- P2) 48" - MH DH RISER Custom Ht T/F - 47"
- P1) 48" - P.I.P. BY OTHERS - BTM SLAB F/n - 0"
- 1) JOINT WRAP - 0.065"x6"x50' CONSEAL CS212
- 1) JOINT WRAP PRIMER - CONSEAL CS-75 (1 gal.)
- 2) 48" - Conseal CS-102 1.00" (Double)
- 2) DOGHOUSE - 10"x10"
- 4) MH Step ML-10-TDS-NCR - 10"

0 lb
 1561 lb
 3191 lb
 0 lb
 0 lb
 0 lb
 0 lb
 0 lb
 0 lb
 0 lb
 0 lb
 Structure Total: 4752 lb

Structure Notes:
 1. PER ASTM C478 SPECIFICATIONS.
 2. CONCRETE = 4,000 PSI AT 28 DAYS.
 3. CASTING SUPPLIED BY OTHERS (HOE MC-375 F/C).

 REINFORCING PER ASTM A615 (GRADE 60).
 - CONE (As .12)
 - RISER (As .12)
 - FLOOR (As .31) #5 BARS AT 12" C.C.E.W.

Rim: 827.7' Rim to Invert: 5.22' Slack: 0.636" Sump: 3.996" Step Position: 90°

Position	Elev	Angle	Ext. (cw)	Pipe	Pipe OD	Connector	Hole	Horz Size	Up (↓)	Offset
Invert 1	822.48'	0°	0"	6" C900 DR18	6.9"	DOGHOUSE 10"x10"	10" x 10"	10.074"	2"	0"
Invert 2	822.48'	180°	91.125"	6" C900 DR18	6.9"	DOGHOUSE 10"x10"	10" x 10"	10.074"	2"	0"
Invert 3										
Invert 4										
Invert 5										
Invert 6										
Invert 7										
Invert 8										

RIGHT-SIDE UP VIEW (int. dimensions)

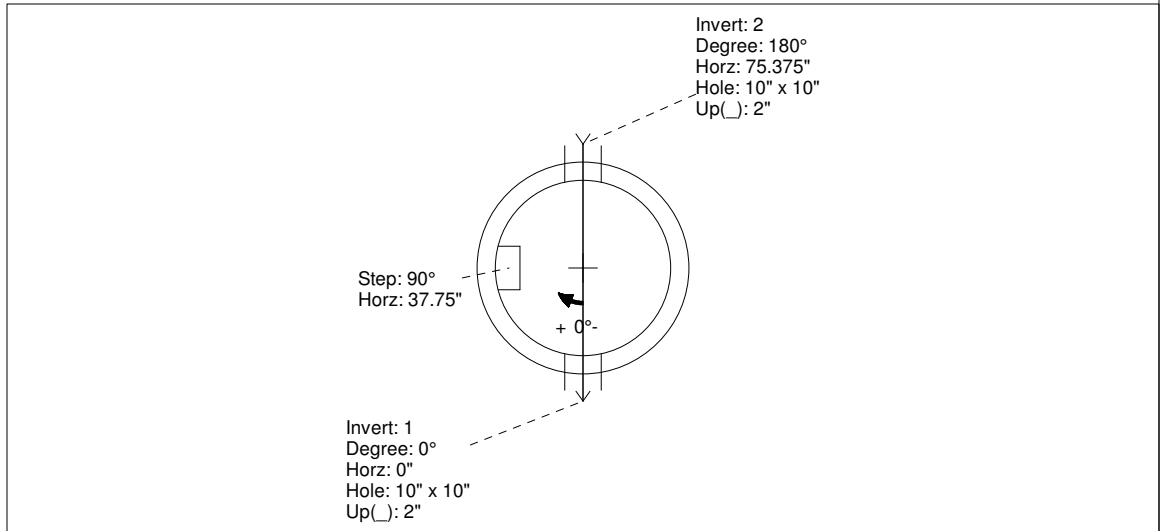
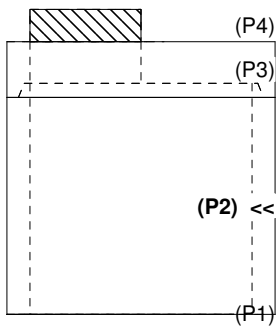

INSIDE WALL DIMENSIONS

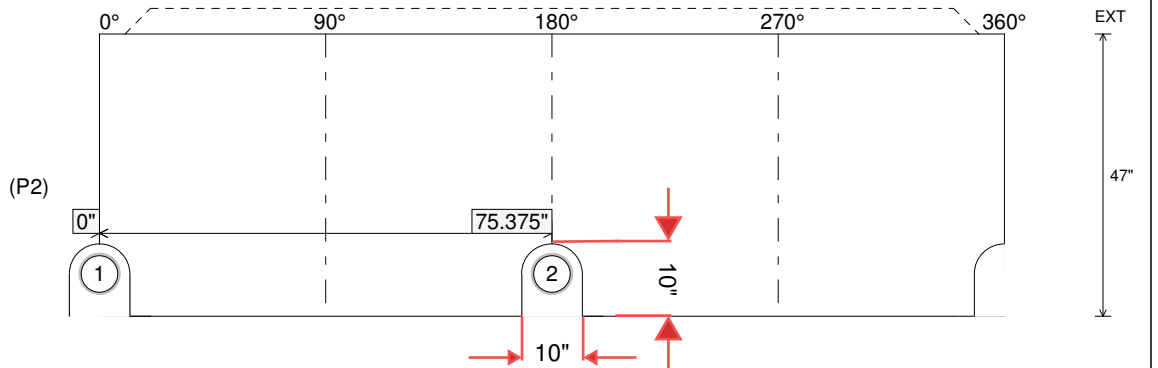

Coating (Int): Coating (Ext):	Seam Up: Tongue Seam Dn: Flat	Wall Thickness: 5" Floor Height: 0"	Height (Int): 47" Height (Ext): 47"	Weight (Net): 3191 lb Volume (Net): 0.82cu.yd
----------------------------------	----------------------------------	--	--	--