

Job Name: 24-3781 Anderson Park At Indian Lake
 Job Location: Hendersonville, TN
 Contractor: Apex

Plant: Beaver Dam

Tech: J. Coppage

1/7/2026 2:04:24 PM

PC: A. Chambers



Structure ID: MH G2

P1 MH048BA36CDARED

MH BASE w/ConBlock-CDA Red

- P3) 24" - CASTING HEIGHT - 6"
- P2) 48" - ECC CONE w/ 24" HOLE, w/ConBlock-CDA Red - 42"
- P1) 48" - MH BASE w/ConBlock-CDA Red - 36"
- 1) JOINT WRAP - 0.065"x6"x50' CONSEAL CS212
- 1) JOINT WRAP PRIMER - CONSEAL CS-75 (1 gal.)
- 1) 48" - MH INVERT CHANNEL w/ConBlock-CDA Red - FULL HEIGHT
- 1) 48" - Conseal CS-102 1.00" (Double)
- 1) PSX - 12-08 NYLO
- 7) MH Step ML-10-TDS-NCR - 10"

- Structure Notes:**
1. JBS-1150 SANITARY PROVIDED BY ICAST.
 2. PER ASTM C478 SPECIFICATIONS.
 3. CONCRETE = 4,000 PSI AT 28 DAYS.
 4. ADMIXTURE = CONBLOCK CDA RED.
 5. REINFORCING PER ASTM A615 (GRADE 60).
- CONE (As .12)
 - RISER/WALLS (As .12)
 - FLOOR (As .31) #5 BARS AT 12" C.C.E.W.

Structure Total: 8362 lb

Rim: 535.7' Rim to Invert: 7' Slack: 2" Sump: 2" Step Position: 180°

Position	Elev	Angle	Ext. (cw)	Pipe	Pipe OD	Connector	Hole	Horz Size	Up ()	Offset
Invert 1	528.7'	0°	0"	8" PVC SDR35	8.5"	PSX 12-08 NYLO	12"	12.129"	0"	0"
Invert 2										
Invert 3										
Invert 4										
Invert 5										
Invert 6										
Invert 7										
Invert 8										

RIGHT-SIDE UP VIEW (int. dimensions)

UPSIDE-DOWN VIEW (int. dimensions)

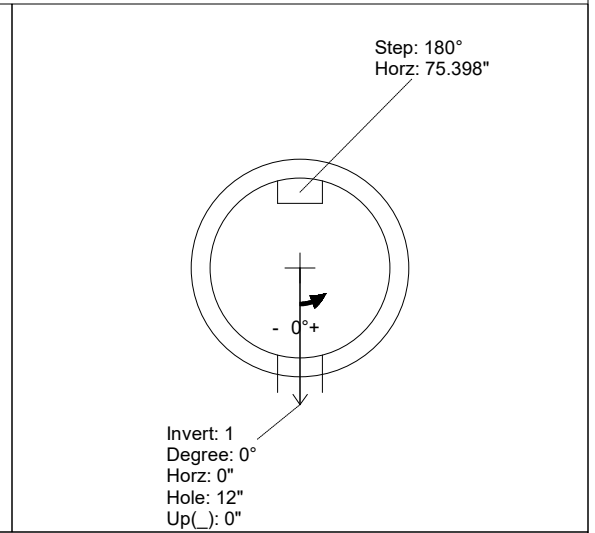
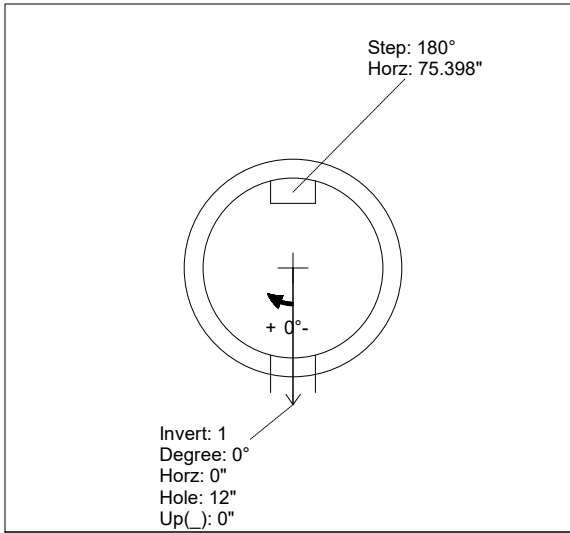
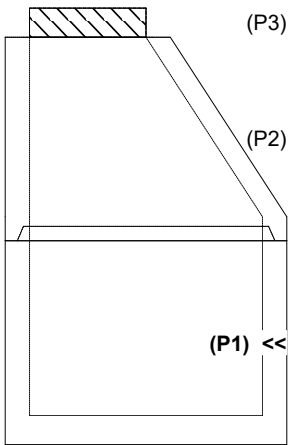

INSIDE WALL DIMENSIONS

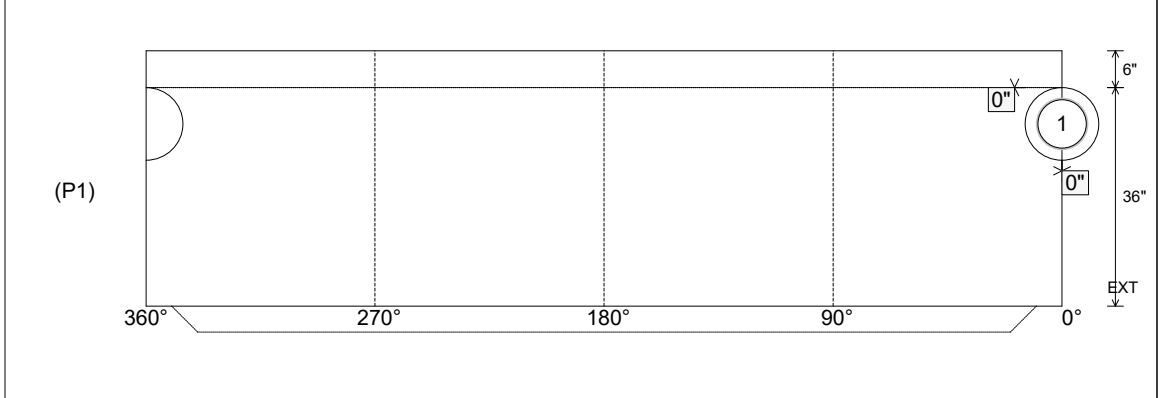

Coating (Int): Coating (Ext):	Seam Up: Tongue Seam Dn: n/a	Wall Thickness: 5" Floor Height: 6"	Height (Int): 36" Height (Ext): 42"	Weight (Net): 3797 lb Volume (Net): 0.97cu.yd
----------------------------------	---------------------------------	--	--	--

Job Name: 24-3781 Anderson Park At Indian Lake
 Job Location: Hendersonville, TN
 Contractor: Apex

Plant: Beaver Dam

Tech: J. Coppage

1/7/2026 2:04:24 PM

PC: A. Chambers



Structure ID: MH G2

P1 MH048BA36CDARED

MH BASE w/ConBlock-CDA Red

- P3) 24" - CASTING HEIGHT - 6"
- P2) 48" - ECC CONE w/ 24" HOLE, w/ConBlock-CDA Red - 42"
- P1) 48" - MH BASE w/ConBlock-CDA Red - 36"
- 1) JOINT WRAP - 0.065"x6"x50' CONSEAL CS212
- 1) JOINT WRAP PRIMER - CONSEAL CS-75 (1 gal.)
- 1) 48" - MH INVERT CHANNEL w/ConBlock-CDA Red - FULL HEIGHT
- 1) 48" - Conseal CS-102 1.00" (Double)
- 1) PSX - 12-08 NYLO
- 7) MH Step ML-10-TDS-NCR - 10"

- Structure Notes:**
1. JBS-1150 SANITARY PROVIDED BY ICAST.
 2. PER ASTM C478 SPECIFICATIONS.
 3. CONCRETE = 4,000 PSI AT 28 DAYS.
 4. ADMIXTURE = CONBLOCK CDA RED.
 5. REINFORCING PER ASTM A615 (GRADE 60).
- CONE (As .12)
 - RISER/WALLS (As .12)
 - FLOOR (As .31) #5 BARS AT 12" C.C.E.W.

Structure Total: 8362 lb

**INVERT CHANNEL DRAWING
 FULL HEIGHT INVERT**

Rim: 535.7' Rim to Invert: 7' Slack: 2" Sump: 2" Step Position: 180°

Position	Elev	Angle	Ext. (cw)	Pipe	Pipe OD	Connector	Hole	Horz Size	Up ()	Offset
Invert 1	528.7'	0°	0"	8" PVC SDR35	8.5"	PSX 12-08 NYLO	12"	12.129"	0"	0"
Invert 2										
Invert 3										
Invert 4										
Invert 5										
Invert 6										
Invert 7										
Invert 8										

RIGHT-SIDE UP VIEW (int. dimensions)

UPSIDE-DOWN VIEW (int. dimensions)

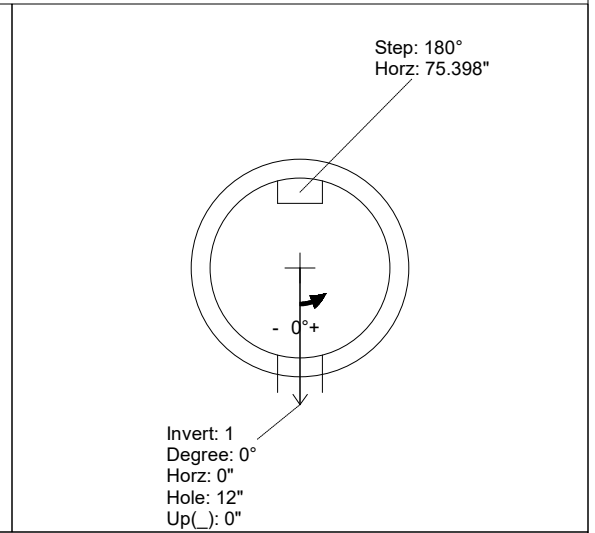
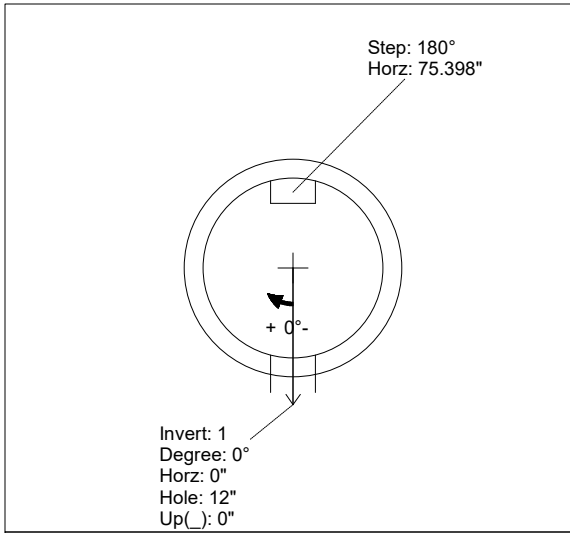
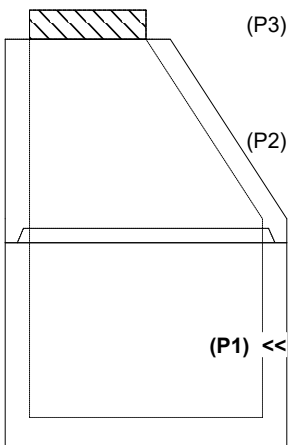

INSIDE WALL DIMENSIONS

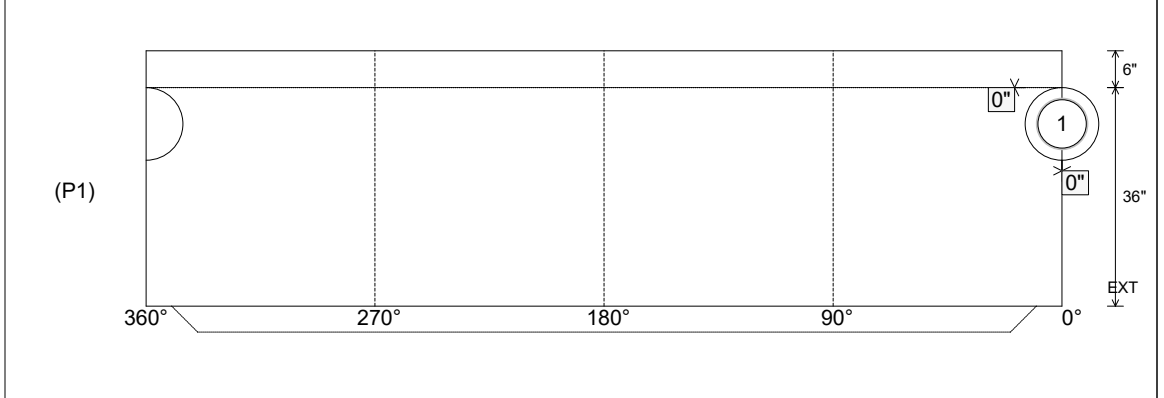

Coating (Int): Coating (Ext):	Seam Up: Tongue Seam Dn: n/a	Wall Thickness: 5" Floor Height: 6"	Height (Int): 36" Height (Ext): 42"	Weight (Net): 3797 lb Volume (Net): 0.97cu.yd
----------------------------------	---------------------------------	--	--	--