

Job Name: 24-3781 Anderson Park At Indian Lake  
 Job Location: Hendersonville, TN  
 Contractor: Apex

Plant: Beaver Dam

1/7/2026 2:04:43 PM

Tech: J. Coppage

PC: A. Chambers



**Structure ID: MH F1**

**P2 MH048CN42CDARED**

**ECC CONE w/ 24" HOLE, w/ConBlock-CDA Red**

- P4) 24" - CASTING HEIGHT - 6"
- P3) 24" - GRADE RING w/ConBlock-CDA Red - 4"
- P2) 48" - ECC CONE w/ 24" HOLE, w/ConBlock-CDA Red - 42"
- P1) 48" - MH BASE w/ConBlock-CDA Red - 36"
- 1) JOINT WRAP - 0.065"x6"x50' CONSEAL CS212
- 1) JOINT WRAP PRIMER - CONSEAL CS-75 (1 gal.)
- 1) 48" - MH INVERT CHANNEL w/ConBlock-CDA Red - FULL HEIGHT
- 1) 48" - Conseal CS-102 1.00" (Double)
- 3) PSX - 12-08 NYLO
- 7) MH Step ML-10-TDS-NCR - 10"

- Structure Notes:**
1. JBS-1150 SANITARY PROVIDED BY ICAST.
  2. PER ASTM C478 SPECIFICATIONS.
  3. CONCRETE = 4,000 PSI AT 28 DAYS.
  4. ADMIXTURE = CONBLOCK CDA RED.
  5. REINFORCING PER ASTM A615 (GRADE 60).
    - CONE (As .12)
    - RISER/WALLS (As .12)
    - FLOOR (As .31) #5 BARS AT 12" C.C.E.W.

Structure Total: 8552 lb

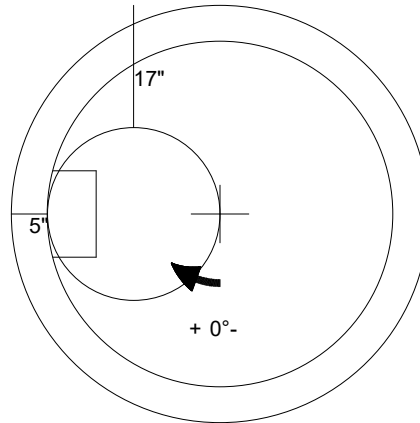

48" - ECC CONE w/ 24" HOLE, w/ConBlock-CDA Red - 42" - (P2)

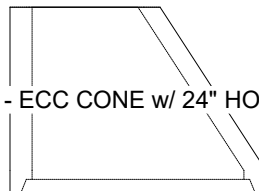

Coating (Int):  
 Coating (Ext):

Seam Up: Flat  
 Seam Dn: Groove

Wall Thickness: 5"

Height (Ext): 42"

Weight (Net): 3116 lb  
 Volume (Net): 0.8cu.yd