

**Structure ID: D6**

**P1 MH060BAVF**

**MH BASE Custom Ht T/n**

P3) 28" x 28" - CASTING HEIGHT - 7.50" P2) 60" - MH FLAT TOP w/(2) 28"x28" Holes F/G - 13" P1) 60" - MH BASE Custom Ht T/n - 67" 1) CASTING - JBS 3300 F/G/H - Double Curb Inlet 1) 60" - Conseal CS-102 1.00" 1) 28" x 28" - Conseal CS-102 1.00" 2) Hole - 26 5) MH Step ML-10-TDS-NCR - 10"	<table style="width:100%; border-collapse: collapse;"> <tr><td style="text-align: right;">0 lb</td><td></td></tr> <tr><td style="text-align: right;">1993 lb</td><td></td></tr> <tr><td style="text-align: right;">9178 lb</td><td></td></tr> <tr><td style="text-align: right;">500 lb</td><td></td></tr> <tr><td style="text-align: right;">0 lb</td><td></td></tr> <tr><td style="text-align: right;">0 lb</td><td></td></tr> <tr><td style="text-align: right;">0 lb</td><td></td></tr> <tr><td style="text-align: right;">0 lb</td><td></td></tr> <tr><td style="text-align: right;">-----</td><td></td></tr> <tr><td style="text-align: right;">11671 lb</td><td></td></tr> </table> <p style="text-align: right;">Structure Total:</p>	0 lb		1993 lb		9178 lb		500 lb		0 lb		0 lb		0 lb		0 lb		-----		11671 lb	
0 lb																					
1993 lb																					
9178 lb																					
500 lb																					
0 lb																					
0 lb																					
0 lb																					
0 lb																					
-----																					
11671 lb																					

**Structure Notes:**

1. PER ASTM C-478 SPECIFICATIONS
2. CONCRETE: 4,000 PSI AT 28 DAYS
3. REINFORCEMENT: PER ASTM A615
4. NO STORM INVERT
5. STEPS AT 180 DEGREES
6. 2 EA. JBS 3300 FRAMES, GRATES, & CURB HOODS SUPPLIED BY ICAST

Rim: 533.8'    Rim to Invert: 7.23'    Slack: 1.76"    Sump: 2.5"    Step Position: 180°

Position	Elev	Angle	Ext. (cw)	Pipe	Pipe OD	Connector	Hole	Horz Size	Up ( )	Offset
Invert 1	526.57'	0°	0"	18" RCP B WALL	23"	Hole 26	26"	26.891"	0"	0"
Invert 2	526.67'	255°	160.25"	18" RCP B WALL	23"	Hole 26	26"	26.891"	1.25"	0"
Invert 3										
Invert 4										
Invert 5										
Invert 6										
Invert 7										
Invert 8										

RIGHT-SIDE UP VIEW (int. dimensions)

UPSIDE-DOWN VIEW (int. dimenions)

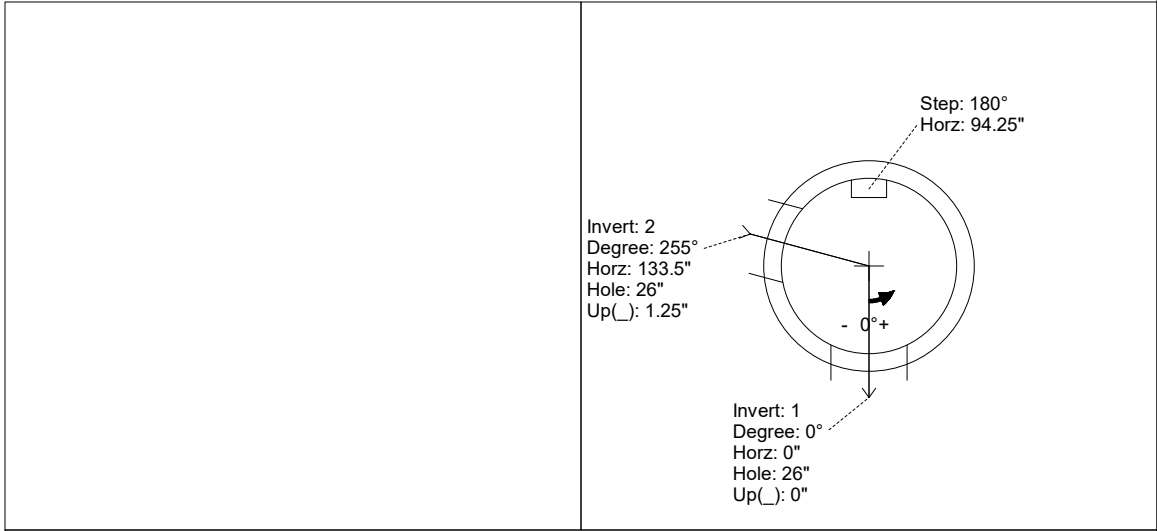
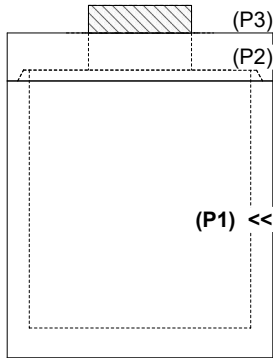

INSIDE WALL DIMENSIONS

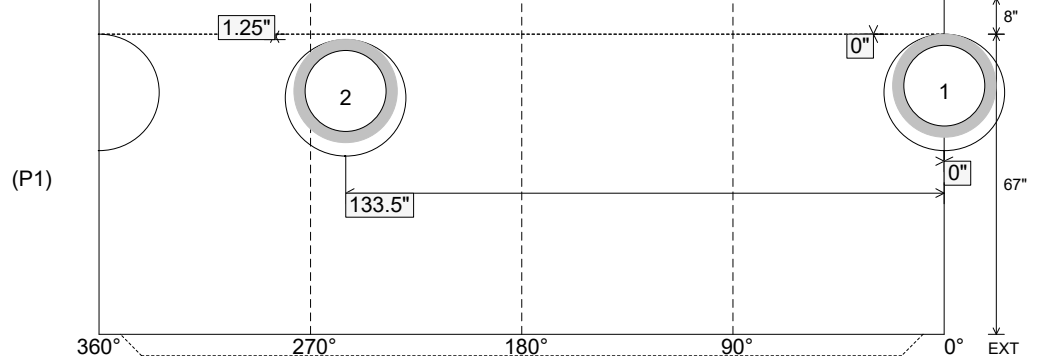

Coating (Int): Coating (Ext):	Seam Up: Tongue Seam Dn: n/a	Wall Thickness: 6" Floor Height: 8"	Height (Int): 67" Height (Ext): 75"	Weight (Net): 9178 lb Volume (Net): 2.34cu.yd
----------------------------------	---------------------------------	--	--	--