

Job Name: 24-3539 - Larkin Springs Townhomes
 Job Location: Nashville, TN
 Contractor: Apex Earthworks, LLC

Plant: 100
 2/25/2026 10:08:00 AM

Tech: J. Horsley - F
 PC: A. Chambers



Structure ID: D5

P1 MH048BA42

MH BASE T/n

- P3) 30" x 30" - CASTING HEIGHT - 7.50"
- P2) 48" - MH FLAT TOP w/30"x30" Hole F/G - 12"
- P1) 48" - MH BASE T/n - 42"
- 1) CASTING - JBS 3300 F/G/H - Single Curb Inlet
- 1) 48" - Conseal CS-102 1.00"
- 1) 30" x 30" - Conseal CS-102 1.00"
- 1) Hole - 26
- 3) MH Step ML-10-TDS-NCR - 10"

0 lb
 1350 lb
 4031 lb
 250 lb
 0 lb
 0 lb
 0 lb
 0 lb
 0 lb
 Structure Total: 5631 lb

- Structure Notes:**
1. PER ASTM C-478 SPECIFICATIONS
 2. CONCRETE: 4,000 PSI AT 28 DAYS
 3. REINFORCEMENT: PER ASTM A615
 4. NO STORM INVERT
 5. STEPS AT 270 DEGREES
 6. JBS 3300 FRAME, GRATE, & CURB HOOD SUPPLIED BY ICAST

Rim: 533.19' Rim to Invert: 5.05' Slack: 1.6" Sump: 2.5" Step Position: 270°

Position	Elev	Angle	Ext. (cw)	Pipe	Pipe OD	Connector	Hole	Horz Size	Up ()	Offset
Invert 1	528.14'	0°	0"	18" RCP B WALL	23"	Hole 26	26"	27.476"	0"	0"
Invert 2										
Invert 3										
Invert 4										
Invert 5										
Invert 6										
Invert 7										
Invert 8										

RIGHT-SIDE UP VIEW (int. dimensions)

UPSIDE-DOWN VIEW (int. dimensions)

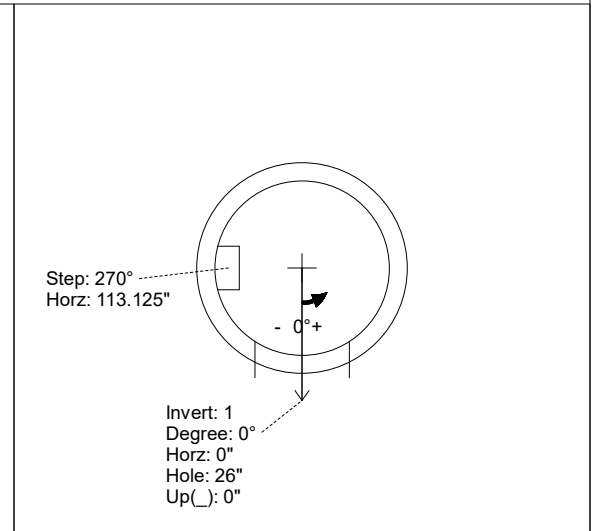
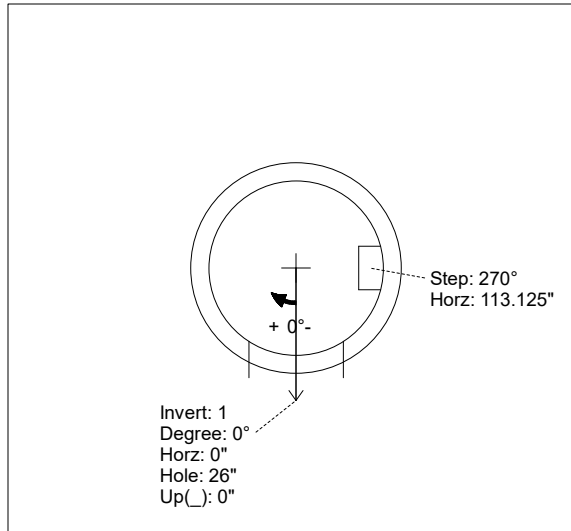
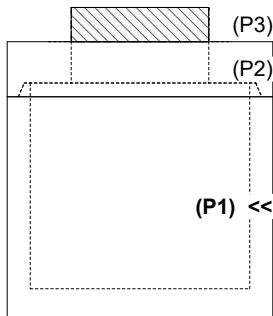

INSIDE WALL DIMENSIONS

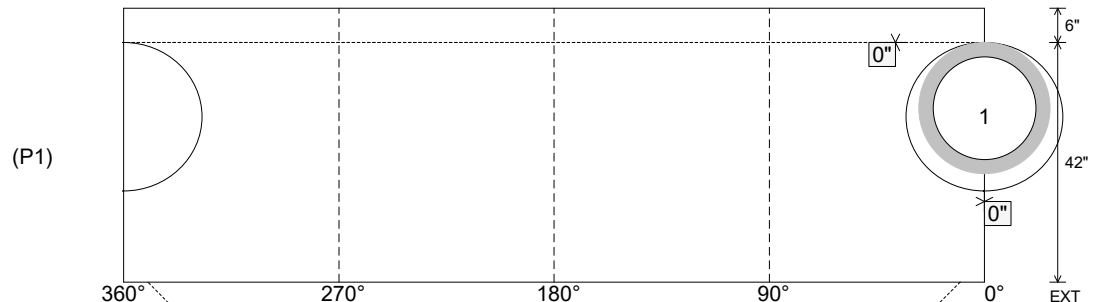

Coating (Int):
 Coating (Ext):

Seam Up: Tongue
 Seam Dn: n/a

Wall Thickness: 5"
 Floor Height: 6"

Height (Int): 42"
 Height (Ext): 48"

Weight (Net): 4031 lb
 Volume (Net): 1.03cu.yd