

**Structure ID: D18**

**P1 BX28640606-VH**

**BOX BASE 6inW, 6inF, Variable Ht F/n**

P2) 28" x 64" - CASTING HEIGHT - 7.50" P1) 28" x 64" - BOX BASE 6inW, 6inF, Variable Ht F/n - 34" 1) CASTING - JBS 3300 F/G/H - Double Curb Inlet 1) 28" x 64" - Conseal CS-102 1.00" 1) Hole - 24 2) LINTEL BAR SLOT n/n - 7"x1"	0 lb 4856 lb 500 lb 0 lb 0 lb 0 lb 0 lb	<b>Structure Notes:</b> 1. PER ASTM C-913 SPECIFICATIONS 2. CONCRETE: 4,000 PSI AT 28 DAYS 3. REINFORCEMENT: #5 BAR @ 12" C.C. E.W. (GRADE 60) - 2" MIN. REBAR CLEARANCE (TYP) 4. NO STORM INVERT 5. NO STEPS 6. 2 EA. JBS 3300 FRAMES, GRATES, & CURB HOODS SUPPLIED BY ICAST 7. LINTEL BAR SLOTS CENTERED IN EACH LONG WALL REQUIRED (7" LONG X 1" DEEP X FULL WIDTH OF WALL)
Structure Total:		5356 lb

Rim: 528'    Rim to Invert: 3.5'    Slack: 2.125"    Sump: 1.625"    Step Position:

Position	Elev	Angle	Ext. (cw)	Pipe	Pipe OD	Connector	Hole	Horz Size	Up ( )	Offset
Invert 1	524.5'	0°	20"	18" HDPE	21.2"	Hole 24	24"	24"	0"	0"
Invert 2	527.11'	90°	38"	7" x 1" LINTEL BAR SLOT	7" x 1"	LINTEL BAR SLOT 7"x1"	7" x 1"	7"	33"	0"
Invert 3	527.11'	270°	38"	7" x 1" LINTEL BAR SLOT	7" x 1"	LINTEL BAR SLOT 7"x1"	7" x 1"	7"	33"	0"
Invert 4										
Invert 5										
Invert 6										
Invert 7										
Invert 8										

RIGHT-SIDE UP VIEW (int. dimensions)

UPSIDE-DOWN VIEW (int. dimensions)

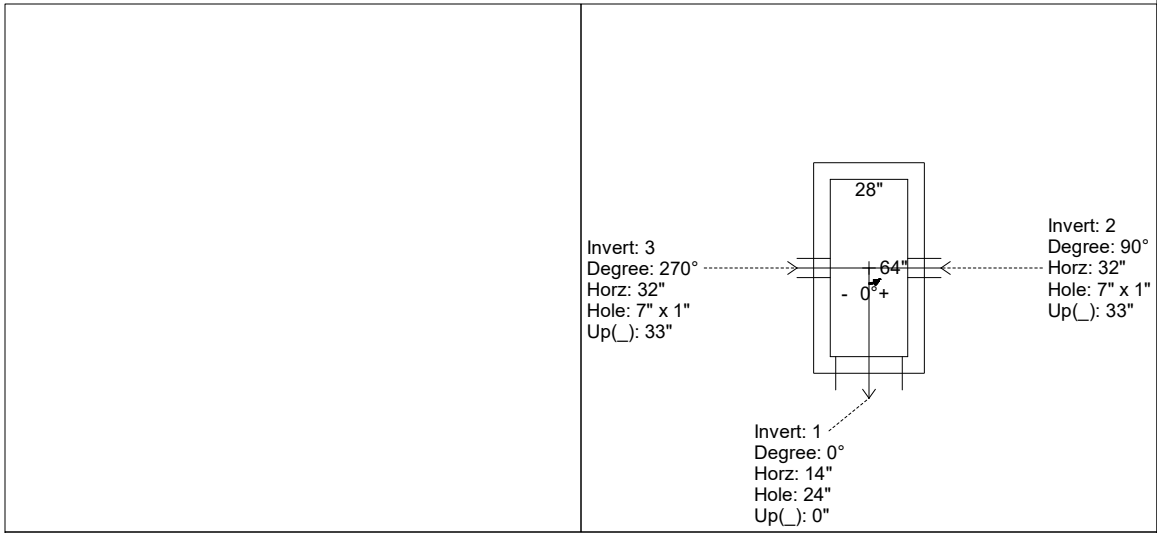
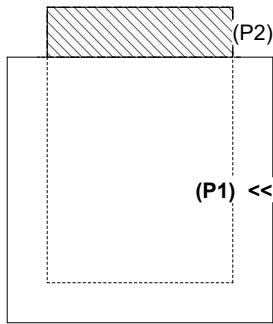

INSIDE WALL DIMENSIONS

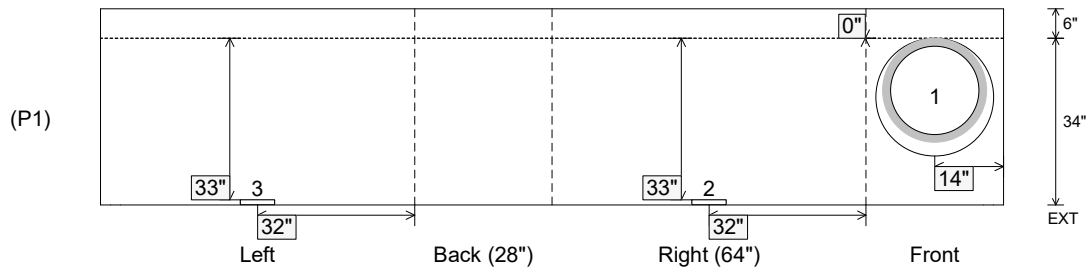

Coating (Int): Coating (Ext):	Seam Up: Flat Seam Dn: n/a	Wall Thickness: 6" Floor Height: 6"	Height (Int): 34" Height (Ext): 40"	Weight (Net): 4856 lb Volume (Net): 1.24cu.yd
----------------------------------	-------------------------------	--	--	--

**GENERAL NOTES:**

- RECESSES FOR LINTEL BARS TO BE 7" LONG X 1" DEEP X FULL WIDTH OF WALL.

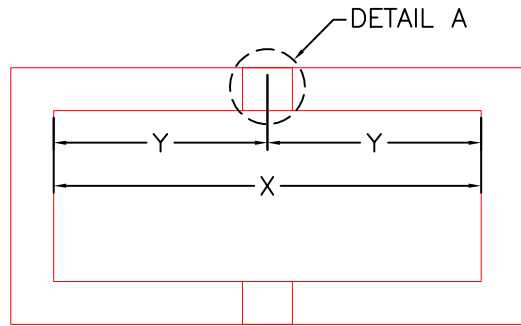

PLAN VIEW  
DOUBLE INLET

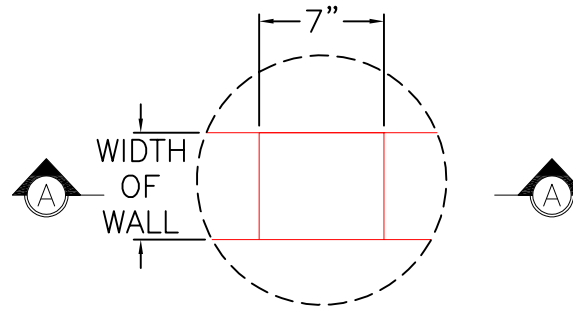

DETAIL A

X	Y
54"	27"
56"	28"
60"	30"
64"	32"
72"	36"

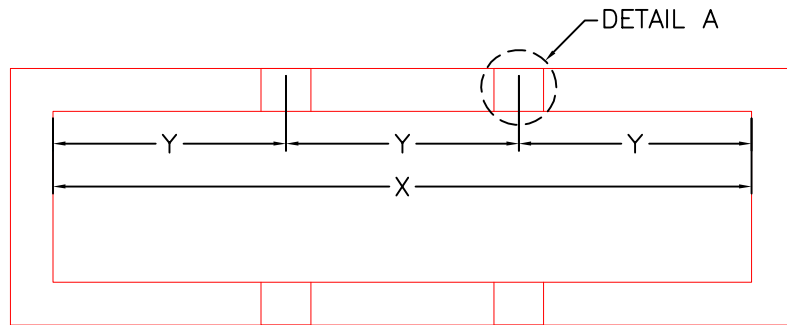

PLAN VIEW  
TRIPLE INLET

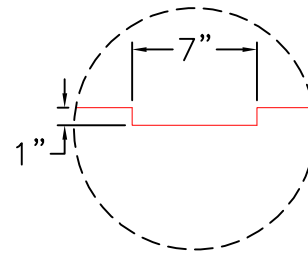

SECTION A-A

X	Y
96"	32"
98"	32 <sup>3</sup> / <sub>4</sub> "
108"	36"

**PRODUCTION WORK ORDER**

PRODUCT I.D.: -

DESCRIPTION: LINTEL BAR POCKET LOCATIONS



QUALITY CONTROL CHECKLIST

- ALL DIMENSIONS CORRECT.
- LIFTERS INSTALLED.
- OPENING CENTERED.
- REINFORCING CORRECT.
- SURFACE QUALITY ACCEPTABLE.
- EDGES CHAMFERED.
- ALL PATCHWORK ACCEPTABLE.

PRODUCT VIEW: RIGHT SIDE UP

CUSTOMER: N/A

PLANT: BEAVER DAM, KY.

PROJECT: N/A

WEIGHT: N/A.

STRUCTURE: N/A

TOP SECTION JOINT: N/A

ORDER NO: N/A

BASE SECTION JOINT: N/A

PE: J.H. ROSS

DRAWING: J. COPPAGE

QC CHECK INITIALS:

DATE: 3/6/24

SCALE: NTS

PG. 1 of 1