

Job Name: 24-3539 - Larkin Springs Townhomes
 Job Location: Nashville, TN
 Contractor: Apex Earthworks, LLC

Plant: 100
 2/25/2026 10:09:10 AM

Tech: J. Horsley - F
 PC: A. Chambers



Structure ID: D16

P2 MH048LD12S

MH FLAT TOP w/30"x30" Hole F/G

- P4) 30" x 30" - CASTING HEIGHT - 7.50"
- P3) 30" x 30" - GRADE RING F/F - 3"
- P2) 48" - MH FLAT TOP w/30"x30" Hole F/G - 12"
- P1) 48" - MH BASE T/n - 48"
- 1) CASTING - JBS 3300 F/G/H - Single Curb Inlet
- 1) 48" - Conseal CS-102 1.00"
- 2) 30" x 30" - Conseal CS-102 1.00"
- 2) Hole - 24
- 4) MH Step ML-10-TDS-NCR - 10"

	0 lb
	218 lb
	1350 lb
	4289 lb
	250 lb
	0 lb
	0 lb
	0 lb
	0 lb
Structure Total:	6106 lb

- Structure Notes:**
1. PER ASTM C-478 SPECIFICATIONS
 2. CONCRETE: 4,000 PSI AT 28 DAYS
 3. REINFORCEMENT: #4 BAR @ 10" C.C. E.W. (GRADE 60) - 2" MIN. REBAR CLEARANCE (TYP)
 4. JBS 3300 FRAME, GRATE, & CURB HOOD SUPPLIED BY ICAST
 5. LIFTERS: 4 EA. WRA016 CONAC WIRE ROPE ANCHORS FOR PLANT & FIELD HANDLING
 6. TOP SURFACE TO RECEIVE FLOATED FINISH

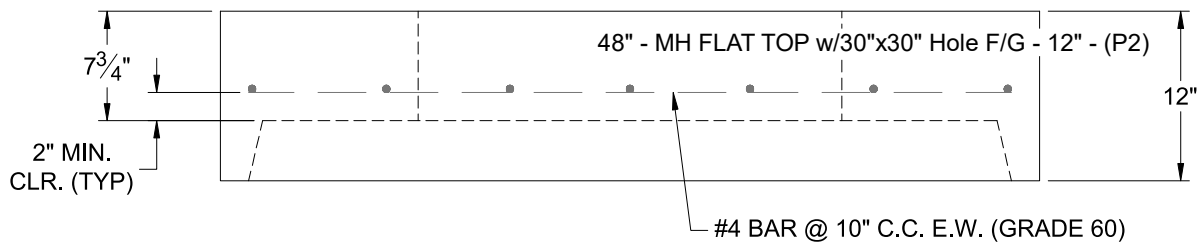
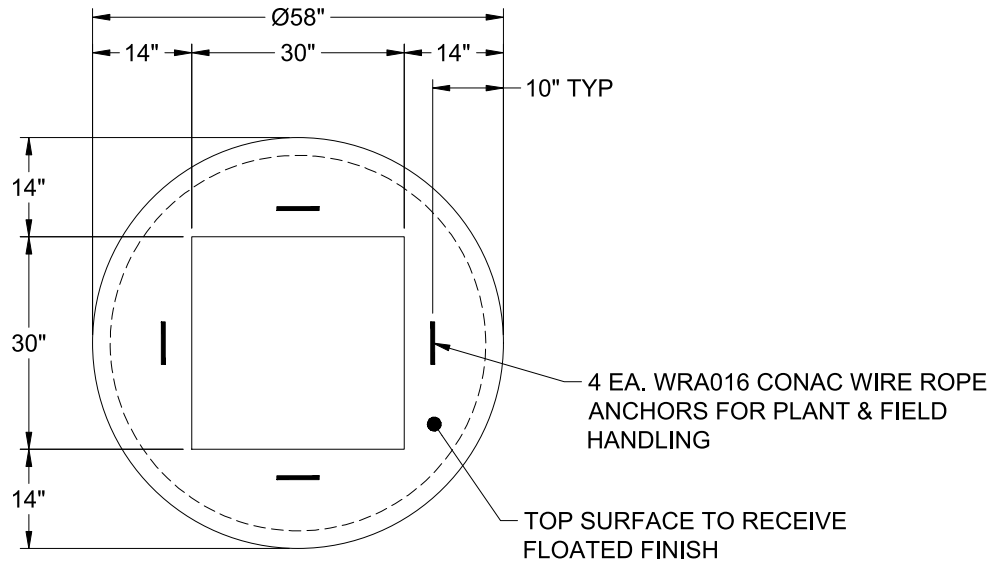

Coating (Int): Coating (Ext):	Seam Up: Flat Seam Dn: Groove	Wall Thickness: 5"	Height (Ext): 12"	Weight (Net): 1350 lb Volume (Net): 0.33cu.yd
----------------------------------	----------------------------------	--------------------	-------------------	--