

Job Name: 24-3539 - Larkin Springs Townhomes
 Job Location: Nashville, TN
 Contractor: Apex Earthworks, LLC

Plant: 100

2/25/2026 10:08:13 AM

Tech: J. Horsley - F

PC: A. Chambers



Structure ID: D16

P1 MH048BA48

MH BASE T/n

- P4) 30" x 30" - CASTING HEIGHT - 7.50"
- P3) 30" x 30" - GRADE RING F/F - 3"
- P2) 48" - MH FLAT TOP w/30"x30" Hole F/G - 12"
- P1) 48" - MH BASE T/n - 48"
- 1) CASTING - JBS 3300 F/G/H - Single Curb Inlet
- 1) 48" - Conseal CS-102 1.00"
- 2) 30" x 30" - Conseal CS-102 1.00"
- 2) Hole - 24
- 4) MH Step ML-10-TDS-NCR - 10"

	0 lb
	218 lb
	1350 lb
	4289 lb
	250 lb
	0 lb
	0 lb
	0 lb
	0 lb
	0 lb
Structure Total:	6106 lb

- Structure Notes:**
1. PER ASTM C-478 SPECIFICATIONS
 2. CONCRETE: 4,000 PSI AT 28 DAYS
 3. REINFORCEMENT: PER ASTM A615
 4. NO STORM INVERT
 5. STEPS AT 270 DEGREES
 6. JBS 3300 FRAME, GRATE, & CURB HOOD SUPPLIED BY ICAST

Rim: 529' Rim to Invert: 5.92' Slack: 2.14" Sump: 1.6" Step Position: 270°

Position	Elev	Angle	Ext. (cw)	Pipe	Pipe OD	Connector	Hole	Horz Size	Up ()	Offset
Invert 1	523.08'	0°	0"	18" HDPE	21.2"	Hole 24	24"	25.133"	0"	0"
Invert 2	523.18'	180°	91.125"	18" HDPE	21.2"	Hole 24	24"	25.133"	1.25"	0"
Invert 3										
Invert 4										
Invert 5										
Invert 6										
Invert 7										
Invert 8										

RIGHT-SIDE UP VIEW (int. dimensions)

UPSIDE-DOWN VIEW (int. dimensions)

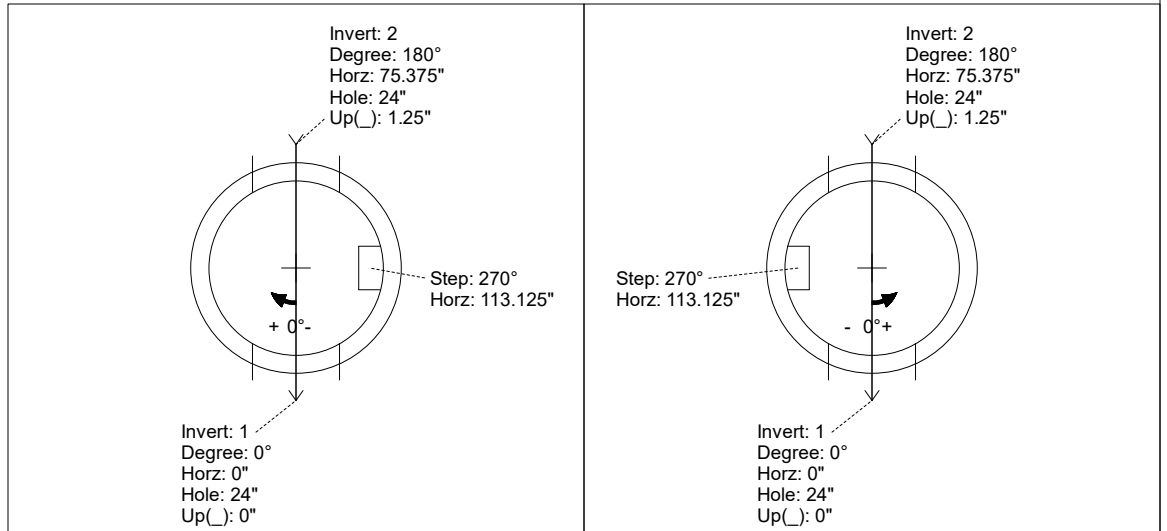
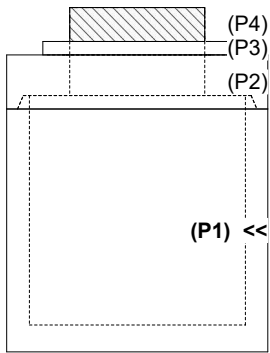

INSIDE WALL DIMENSIONS

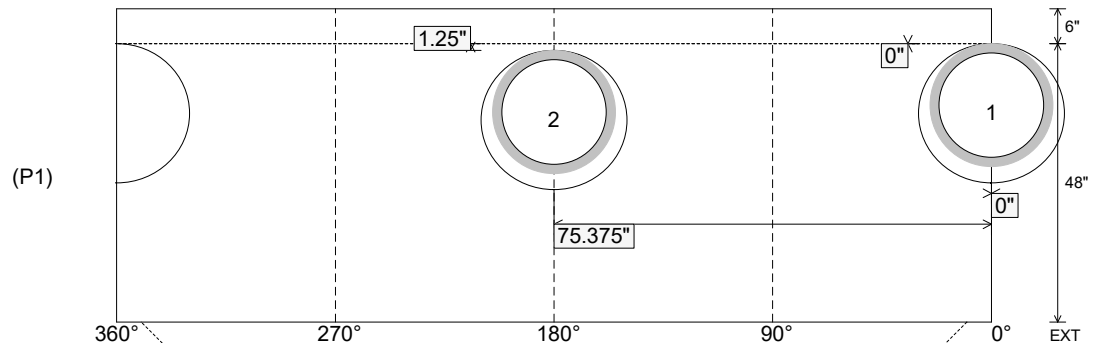

Coating (Int):
 Coating (Ext):

Seam Up: Tongue
 Seam Dn: n/a

Wall Thickness: 5"
 Floor Height: 6"

Height (Int): 48"
 Height (Ext): 54"

Weight (Net): 4289 lb
 Volume (Net): 1.1cu.yd