

Job Name: 24-3539 - Larkin Springs Townhomes  
 Job Location: Nashville, TN  
 Contractor: Apex Earthworks, LLC

Plant: 100

1/5/2026 11:48:35 AM

Tech: J. Horsley - F

PC: A. Chambers



**Structure ID: 9**

**P3 GR3CDARED**

**GRADE RING w/ConBlock-CDA Red F/F**

- P4) 24" - CASTING HEIGHT - 7"
- P3) 24" - GRADE RING w/ConBlock-CDA Red F/F - 3"
- P2) 48" - CON CONE w/24" HOLE, w/ConBlock-CDA Red F/G - 24"
- P1) 48" - MH BASE w/ConBlock-CDA Red T/n - 24"
- 1) JOINT WRAP - 0.065"x12"x50' CONSEAL CS212
- 1) JOINT WRAP PRIMER - CONSEAL CS-75 (1 gal.)
- 1) ADMIXTURE CONBLOCK CDA RED
- 1) 48" - MH INVERT CHANNEL w/ConBlock-CDA Red - FULL HEIGHT
- 1) CASTING - JBS 1150 F/C SANITARY
- 1) 48" - Conseal CS-102 1.00" (Double)
- 1) PSX - 12-08 NYLO
- 4) MH Step ML-10-TDS-NCR - 10"

0 lb  
 202 lb  
 1297 lb  
 2959 lb  
 0 lb  
 0 lb  
 0 lb  
 1440 lb  
 250 lb  
 0 lb  
 8 lb  
 0 lb

Structure Total: 6156 lb

Structure Notes:

1. PER ASTM C-478 SPECIFICATIONS
2. CONCRETE: 4,000 PSI AT 28 DAYS
3. REINFORCEMENT: (1) #3 HOOP CENTERED (GRADE 60)
4. CONBLOCK CDA RED ADMIXTURE REQUIRED

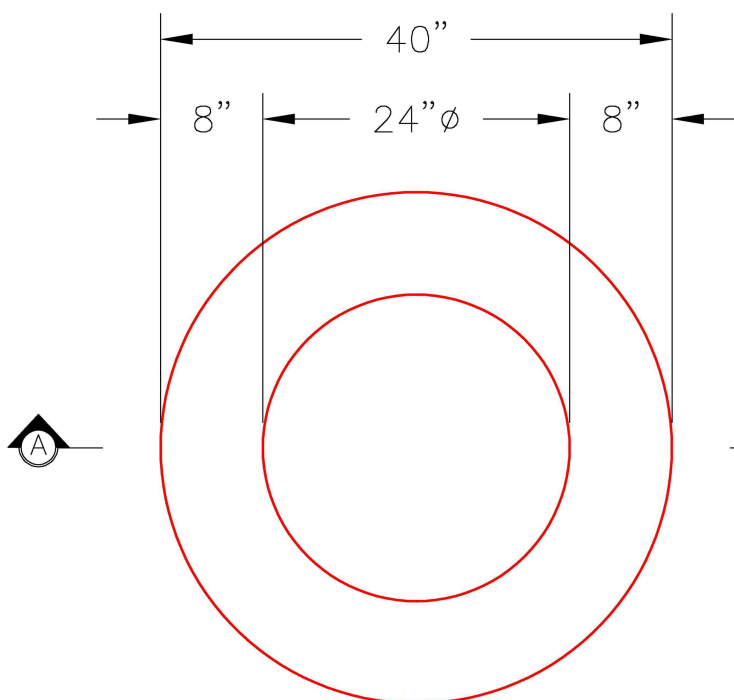

**PLAN VIEW**

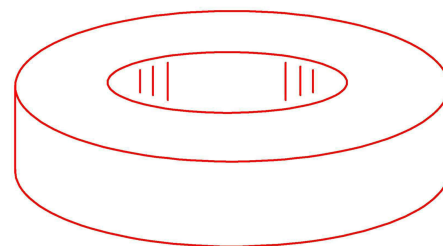

**ISOMETRIC VIEW**

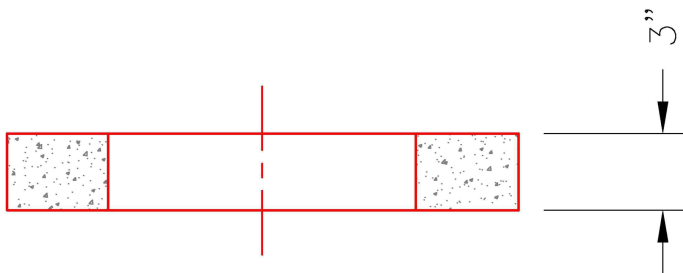

**SECTION A-A**

Coating (Int):  
 Coating (Ext):

Seam Up: Flat  
 Seam Dn: Flat

Wall Thickness: 8"

Height (Ext): 3"

Weight (Net): 202 lb  
 Volume (Net): 0.05cu.yd