

Job Name: 24-3539 - Larkin Springs Townhomes
 Job Location: Nashville, TN
 Contractor: Apex Earthworks, LLC

Plant: 100

Tech: J. Horsley - F

1/5/2026 11:48:34 AM

PC: A. Chambers



Structure ID: 9

P2 MH048CCN24CDARED

CON CONE w/24" HOLE, w/ConBlock-CDA Red F/G

- P4) 24" - CASTING HEIGHT - 7"
- P3) 24" - GRADE RING w/ConBlock-CDA Red F/F - 3"
- P2) 48" - CON CONE w/24" HOLE, w/ConBlock-CDA Red F/G - 24"
- P1) 48" - MH BASE w/ConBlock-CDA Red T/n - 24"
- 1) JOINT WRAP - 0.065"x12"x50' CONSEAL CS212
- 1) JOINT WRAP PRIMER - CONSEAL CS-75 (1 gal.)
- 1) ADMIXTURE CONBLOCK CDA RED
- 1) 48" - MH INVERT CHANNEL w/ConBlock-CDA Red - FULL HEIGHT
- 1) CASTING - JBS 1150 F/C SANITARY
- 1) 48" - Conseal CS-102 1.00" (Double)
- 1) PSX - 12-08 NYLO
- 4) MH Step ML-10-TDS-NCR - 10"

0 lb
 202 lb
 1297 lb
 2959 lb
 0 lb
 0 lb
 0 lb
 1440 lb
 250 lb
 0 lb
 8 lb
 0 lb

- Structure Notes:
1. PER ASTM C-478 SPECIFICATIONS
 2. CONCRETE: 4,000 PSI AT 28 DAYS
 3. REINFORCEMENT: PER ASTM A615
 4. INVERT CHANNEL REQUIRED
 5. CONBLOCK CDA RED ADMIXTURE REQUIRED
 6. STEPS AT 180 DEGREES
 7. CASTING BY ICAST (JBS 1150 FRAME & COVER "SANITARY")

Structure Total: 6156 lb

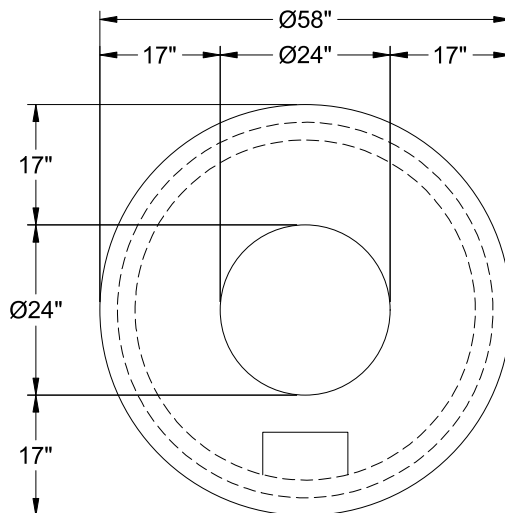

48" - CON CONE w/24" HOLE, w/ConBlock-CDA Red F/G - 24" - (P2)

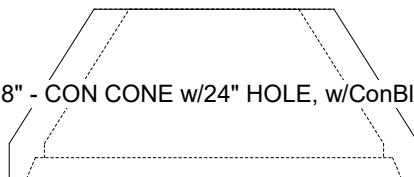

Coating (Int):
 Coating (Ext):

Seam Up: Flat
 Seam Dn: Groove

Wall Thickness: 5"

Height (Ext): 24"

Weight (Net): 1297 lb
 Volume (Net): 0.33cu.yd