

Job Name: 24-3539 - Larkin Springs Townhomes
 Job Location: Nashville, TN
 Contractor: Apex Earthworks, LLC

Plant: 100

1/5/2026 11:54:29 AM

Tech: J. Horsley - F

PC: A. Chambers



Structure ID: 9

P1 MH048BA24CDARED

MH BASE w/ConBlock-CDA Red T/n

- P4) 24" - CASTING HEIGHT - 7" 0 lb
 - P3) 24" - GRADE RING w/ConBlock-CDA Red F/F - 3" 202 lb
 - P2) 48" - CON CONE w/24" HOLE, w/ConBlock-CDA Red F/G - 24" 1297 lb
 - P1) 48" - MH BASE w/ConBlock-CDA Red T/n - 24" 2959 lb
 - 1) JOINT WRAP - 0.065"x12"x50' CONSEAL CS212 0 lb
 - 1) JOINT WRAP PRIMER - CONSEAL CS-75 (1 gal.) 0 lb
 - 1) ADMIXTURE CONBLOCK CDA RED 0 lb
 - 1) 48" - MH INVERT CHANNEL w/ConBlock-CDA Red - FULL HEIGHT 1440 lb
 - 1) CASTING - JBS 1150 F/C SANITARY 250 lb
 - 1) 48" - Conseal CS-102 1.00" (Double) 0 lb
 - 1) PSX - 12-08 NYLO 8 lb
 - 4) MH Step ML-10-TDS-NCR - 10" 0 lb
- Structure Total: 6156 lb

- Structure Notes:**
1. PER ASTM C-478 SPECIFICATIONS
 2. CONCRETE: 4,000 PSI AT 28 DAYS
 3. REINFORCEMENT: PER ASTM A615
 4. INVERT CHANNEL REQUIRED
 5. CONBLOCK CDA RED ADMIXTURE REQUIRED
 6. STEPS AT 180 DEGREES
 7. CASTING BY ICAST (JBS 1150 FRAME & COVER "SANITARY")

Rim: 547' Rim to Invert: 4.67' Slack: 0.04" Sump: 2" Step Position: 180°

Position	Elev	Angle	Ext. (cw)	Pipe	Pipe OD	Connector	Hole	Horz Size	Up ()	Offset
Invert 1	542.33'	0°	0"	8" PVC SDR35	8.5"	PSX 12-08 NYLO	12"	12.129"	0"	0"
Invert 2										
Invert 3										
Invert 4										
Invert 5										
Invert 6										
Invert 7										
Invert 8										

RIGHT-SIDE UP VIEW (int. dimensions)

UPSIDE-DOWN VIEW (int. dimensions)

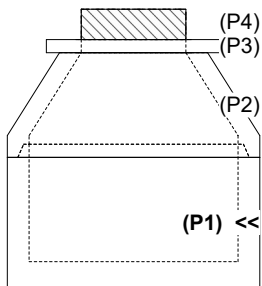
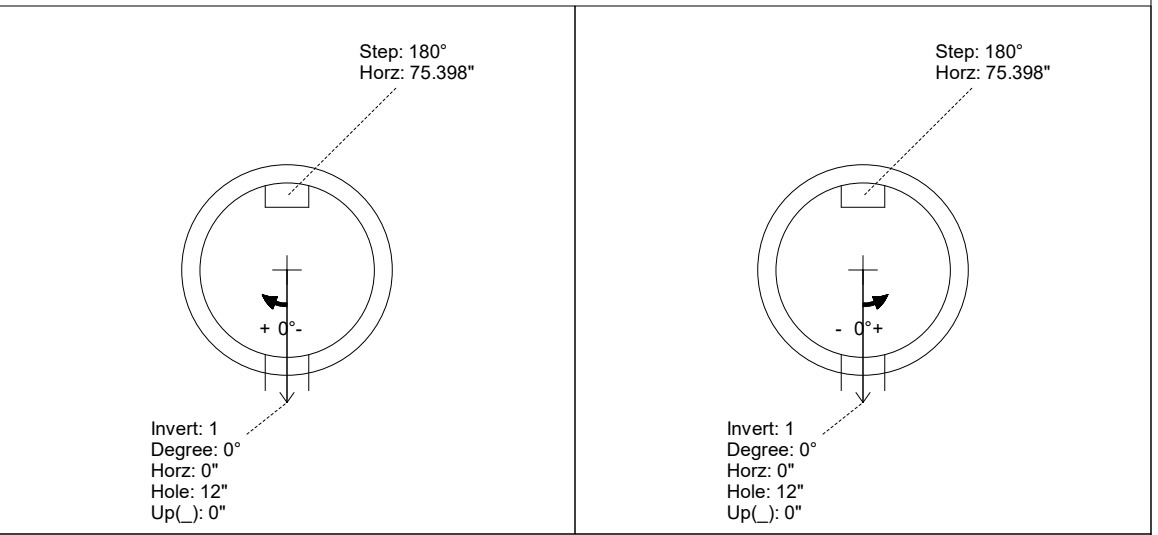

INSIDE WALL DIMENSIONS

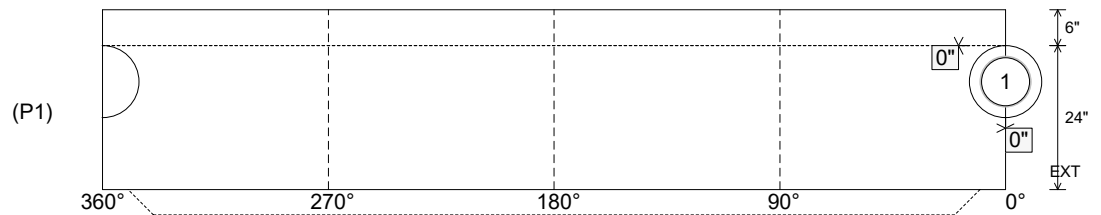

Coating (Int):
Coating (Ext):

Seam Up: Tongue
Seam Dn: n/a

Wall Thickness: 5"
Floor Height: 6"

Height (Int): 24"
Height (Ext): 30"

Weight (Net): 2959 lb
Volume (Net): 0.76cu.yd

Structure ID: 9

P1 MH048BA24CDARED

MH BASE w/ConBlock-CDA Red T/n

P4) 24" - CASTING HEIGHT - 7" P3) 24" - GRADE RING w/ConBlock-CDA Red F/F - 3" P2) 48" - CON CONE w/24" HOLE, w/ConBlock-CDA Red F/G - 24" P1) 48" - MH BASE w/ConBlock-CDA Red T/n - 24" 1) JOINT WRAP - 0.065"x12"x50' CONSEAL CS212 1) JOINT WRAP PRIMER - CONSEAL CS-75 (1 gal.) 1) ADMIXTURE CONBLOCK CDA RED 1) 48" - MH INVERT CHANNEL w/ConBlock-CDA Red - FULL HEIGHT 1) CASTING - JBS 1150 F/C SANITARY 1) 48" - Conseal CS-102 1.00" (Double) 1) PSX - 12-08 NYLO 4) MH Step ML-10-TDS-NCR - 10"	0 lb 202 lb 1297 lb 2959 lb 0 lb 0 lb 0 lb 1440 lb 250 lb 0 lb 8 lb 0 lb ----- Structure Total: 6156 lb
--	--

- Structure Notes:**
1. PER ASTM C-478 SPECIFICATIONS
 2. CONCRETE: 4,000 PSI AT 28 DAYS
 3. REINFORCEMENT: PER ASTM A615
 4. INVERT CHANNEL REQUIRED
 5. CONBLOCK CDA RED ADMIXTURE REQUIRED
 6. STEPS AT 180 DEGREES
 7. CASTING BY ICAST (JBS 1150 FRAME & COVER "SANITARY")

Rim: 547' Rim to Invert: 4.67' Slack: 0.04" Sump: 2" Step Position: 180°

Position	Elev	Angle	Ext. (cw)	Pipe	Pipe OD	Connector	Hole	Horz Size	Up ()	Offset
Invert 1	542.33'	0°	0"	8" PVC SDR35	8.5"	PSX 12-08 NYLO	12"	12.129"	0"	0"
Invert 2										
Invert 3										
Invert 4										
Invert 5										
Invert 6										
Invert 7										
Invert 8										

RIGHT-SIDE UP VIEW (int. dimensions)

UPSIDE-DOWN VIEW (int. dimensions)

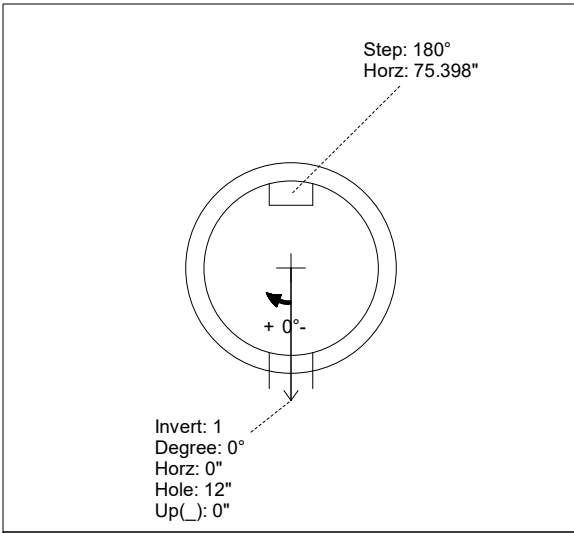

INVERT CHANNEL
DRAWING

INSIDE WALL DIMENSIONS

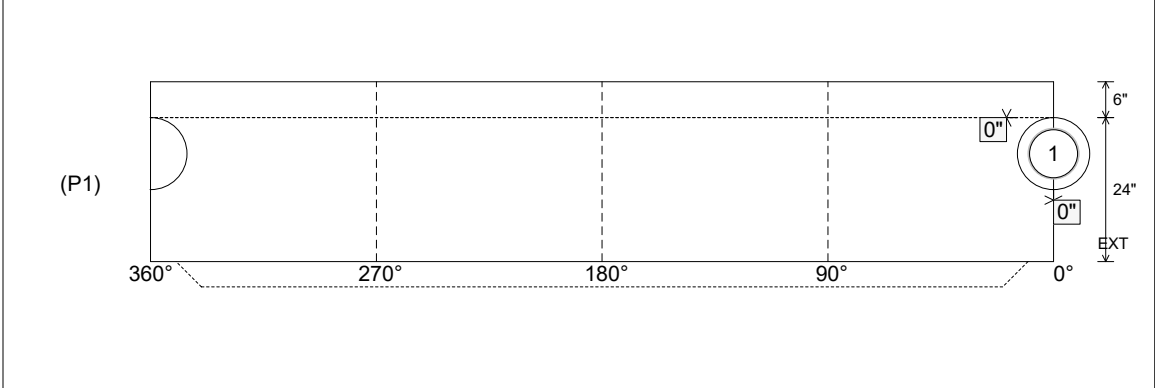

Coating (Int): Coating (Ext):	Seam Up: Tongue Seam Dn: n/a	Wall Thickness: 5" Floor Height: 6"	Height (Int): 24" Height (Ext): 30"	Weight (Net): 2959 lb Volume (Net): 0.76cu.yd
----------------------------------	---------------------------------	--	--	--