

Job Name: 24-3539 - Larkin Springs Townhomes  
 Job Location: Nashville, TN  
 Contractor: Apex Earthworks, LLC

Plant: 100

1/5/2026 11:48:34 AM

Tech: J. Horsley - F

PC: A. Chambers



**Structure ID: 8**

**P4 GR4CDARED**

**GRADE RING w/ConBlock-CDA Red F/F**

- P5) 24" - CASTING HEIGHT - 7"
- P4) 24" - GRADE RING w/ConBlock-CDA Red F/F - 4"
- P3) 48" - CON CONE w/24" HOLE, w/ConBlock-CDA Red F/G - 36"
- P2) 48" - MH RISER w/ConBlock-CDA Red T/G - 48"
- P1) 48" - MH BASE w/ConBlock-CDA Red T/n - 30"
- 1) JOINT WRAP - 0.065"x12"x50' CONSEAL CS212
- 1) JOINT WRAP PRIMER - CONSEAL CS-75 (1 gal.)
- 1) ADMIXTURE CONBLOCK CDA RED
- 1) 48" - MH INVERT CHANNEL w/ConBlock-CDA Red - FULL HEIGHT
- 1) CASTING - JBS 1150 F/C SANITARY
- 2) 48" - Conseal CS-102 1.00" (Double)
- 1) PSX - 12M NYLO
- 1) PSX - 12-08 NYLO
- 9) MH Step ML-10-TDS-NCR - 10"

0 lb  
 270 lb  
 2251 lb  
 3353 lb  
 3330 lb  
 0 lb  
 0 lb  
 0 lb  
 1440 lb  
 250 lb  
 0 lb  
 8 lb  
 8 lb  
 0 lb  
 -----  
 Structure Total: 10910 lb

- Structure Notes:
1. PER ASTM C-478 SPECIFICATIONS
  2. CONCRETE: 4,000 PSI AT 28 DAYS
  3. REINFORCEMENT: (1) #3 HOOP CENTERED (GRADE 60)
  4. CONBLOCK CDA RED ADMIXTURE REQUIRED

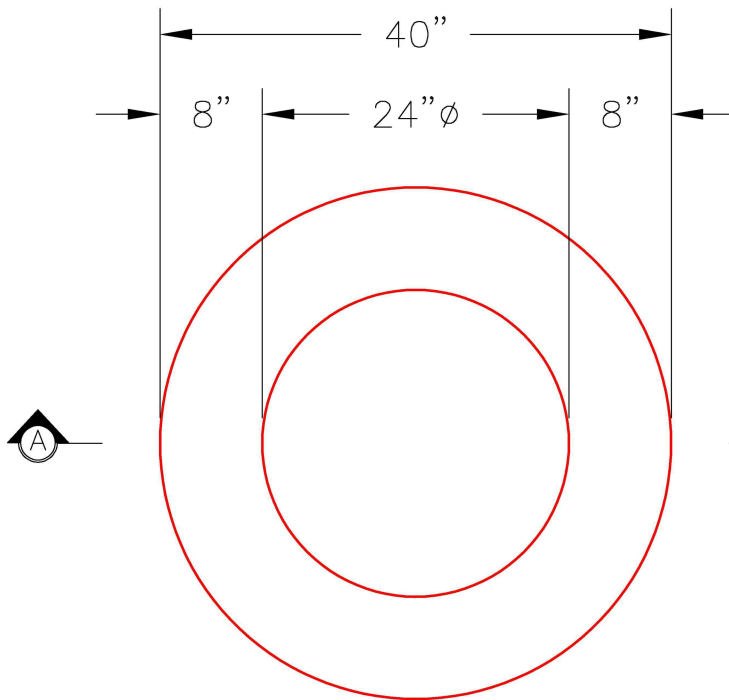

**PLAN VIEW**

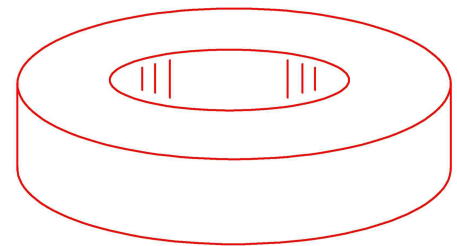

**ISOMETRIC VIEW**

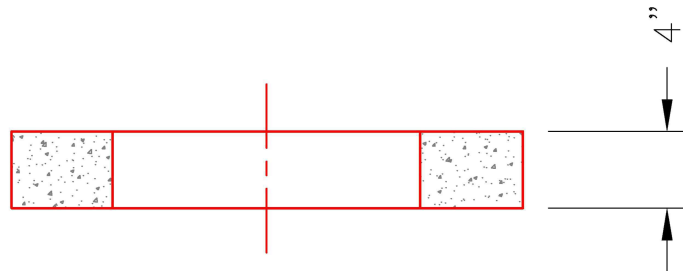

**SECTION A-A**

Coating (Int):  
 Coating (Ext):

Seam Up: Flat  
 Seam Dn: Flat

Wall Thickness: 8"

Height (Ext): 4"

Weight (Net): 270 lb  
 Volume (Net): 0.07cu.yd