

Job Name: 24-3539 - Larkin Springs Townhomes
 Job Location: Nashville, TN
 Contractor: Apex Earthworks, LLC

Plant: 100

1/5/2026 11:48:33 AM

Tech: J. Horsley - F

PC: A. Chambers



Structure ID: 7

P3 GR3CDARED

GRADE RING w/ConBlock-CDA Red F/F

- P4) 24" - CASTING HEIGHT - 7"
- P3) 24" - GRADE RING w/ConBlock-CDA Red F/F - 3"
- P2) 48" - CON CONE w/24" HOLE, w/ConBlock-CDA Red F/G - 24"
- P1) 48" - MH BASE w/ConBlock-CDA Red T/n - 24"
- 1) JOINT WRAP - 0.065"x12"x50' CONSEAL CS212
- 1) JOINT WRAP PRIMER - CONSEAL CS-75 (1 gal.)
- 1) ADMIXTURE CONBLOCK CDA RED
- 1) 48" - MH INVERT CHANNEL w/ConBlock-CDA Red - FULL HEIGHT
- 1) CASTING - JBS 1150 F/C SANITARY
- 1) 48" - Conseal CS-102 1.00" (Double)
- 1) PSX - 12-08 NYLO
- 4) MH Step ML-10-TDS-NCR - 10"

- 0 lb
- 202 lb
- 1297 lb
- 2959 lb
- 0 lb
- 0 lb
- 0 lb
- 1440 lb
- 250 lb
- 0 lb
- 8 lb
- 0 lb

Structure Total: 6156 lb

Structure Notes:

1. PER ASTM C-478 SPECIFICATIONS
2. CONCRETE: 4,000 PSI AT 28 DAYS
3. REINFORCEMENT: (1) #3 HOOP CENTERED (GRADE 60)
4. CONBLOCK CDA RED ADMIXTURE REQUIRED

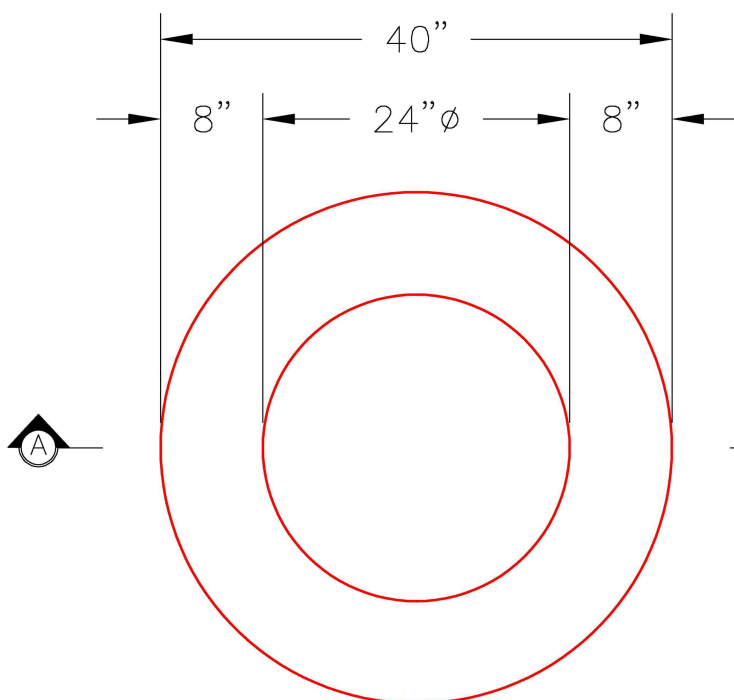

PLAN VIEW

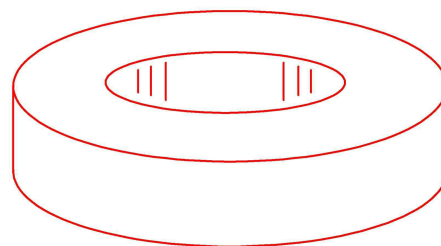

ISOMETRIC VIEW

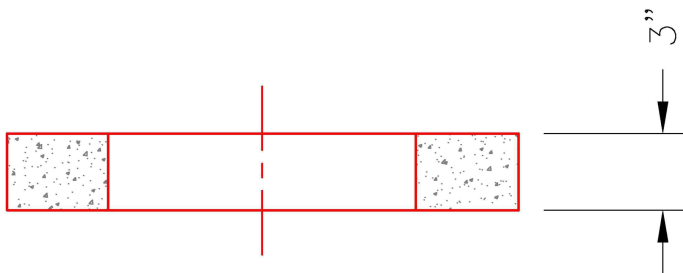

SECTION A-A

Coating (Int):
 Coating (Ext):

Seam Up: Flat
 Seam Dn: Flat

Wall Thickness: 8"

Height (Ext): 3"

Weight (Net): 202 lb
 Volume (Net): 0.05cu.yd