

Job Name: 24-3539 - Larkin Springs Townhomes
 Job Location: Nashville, TN
 Contractor: Apex Earthworks, LLC

Plant: 100

Tech: J. Horsley - F

1/5/2026 11:54:34 AM

PC: A. Chambers



Structure ID: 4

P1 MH048BA30CDARED

MH BASE w/ConBlock-CDA Red T/n

P5) 24" - CASTING HEIGHT - 7"	0 lb
P4) 24" - GRADE RING w/ConBlock-CDA Red F/F - 3"	202 lb
P3) 48" - CON CONE w/24" HOLE, w/ConBlock-CDA Red F/G - 24"	1297 lb
P2) 48" - MH RISER w/ConBlock-CDA Red T/G - 24"	1677 lb
P1) 48" - MH BASE w/ConBlock-CDA Red T/n - 30"	3330 lb
1) JOINT WRAP - 0.065"x12"x50' CONSEAL CS212	0 lb
1) JOINT WRAP PRIMER - CONSEAL CS-75 (1 gal.)	0 lb
1) ADMIXTURE CONBLOCK CDA RED	0 lb
1) 48" - MH INVERT CHANNEL w/ConBlock-CDA Red - FULL HEIGHT	1440 lb
1) CASTING - JBS 1150 F/C SANITARY	250 lb
2) 48" - Conseal CS-102 1.00" (Double)	0 lb
1) PSX - 12-08 NYLO	8 lb
1) PSX - 12M NYLO	8 lb
6) MH Step ML-10-TDS-NCR - 10"	0 lb
Structure Total:	8212 lb

Structure Notes:
 1. PER ASTM C-478 SPECIFICATIONS
 2. CONCRETE: 4,000 PSI AT 28 DAYS
 3. REINFORCEMENT: PER ASTM A615
 4. INVERT CHANNEL REQUIRED
 5. CONBLOCK CDA RED ADMIXTURE REQUIRED
 6. STEPS AT 225 DEGREES
 7. CASTING BY ICAST (JBS 1150 FRAME & COVER "SANITARY")

Rim: 544.1' Rim to Invert: 7.21' Slack: 0.52" Sump: 2" Step Position: 225°

Position	Elev	Angle	Ext. (cw)	Pipe	Pipe OD	Connector	Hole	Horz Size	Up ()	Offset
Invert 1	536.89'	0°	0"	8" PVC SDR35	8.5"	PSX 12-08 NYLO	12"	12.129"	0"	0"
Invert 2	537.09'	90°	45.553"	8" DI	9"	PSX 12M NYLO	12"	12.129"	2.4"	0"
Invert 3										
Invert 4										
Invert 5										
Invert 6										
Invert 7										
Invert 8										

RIGHT-SIDE UP VIEW (int. dimensions)

UPSIDE-DOWN VIEW (int. dimensions)

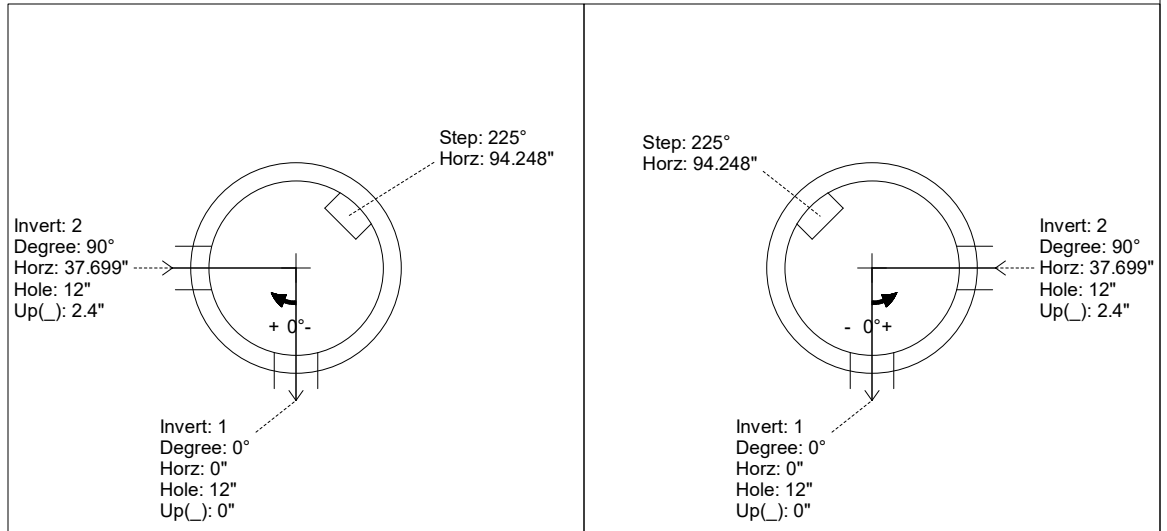

INSIDE WALL DIMENSIONS

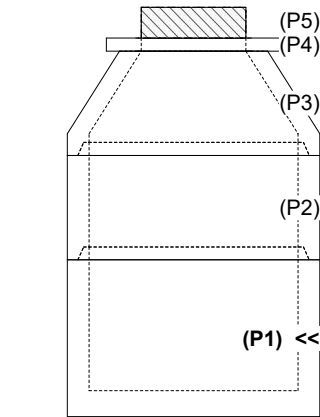
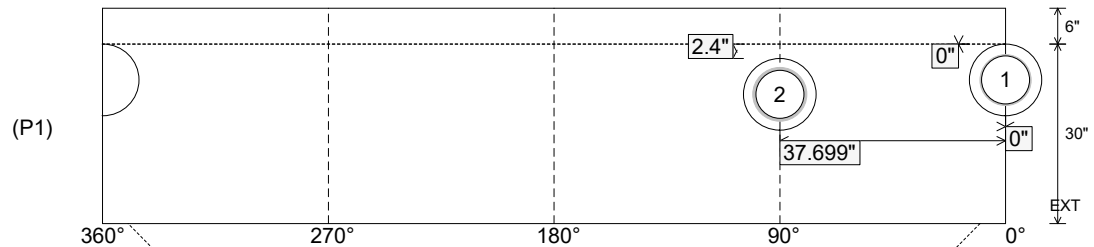

Coating (Int):
 Coating (Ext):

Seam Up: Tongue
 Seam Dn: n/a

Wall Thickness: 5"
 Floor Height: 6"

Height (Int): 30"
 Height (Ext): 36"

Weight (Net): 3330 lb
 Volume (Net): 0.85cu.yd

Job Name: 24-3539 - Larkin Springs Townhomes
 Job Location: Nashville, TN
 Contractor: Apex Earthworks, LLC

Plant: 100

Tech: J. Horsley - F

1/5/2026 11:54:34 AM

PC: A. Chambers



Structure ID: 4

P1 MH048BA30CDARED

MH BASE w/ConBlock-CDA Red T/n

P5) 24" - CASTING HEIGHT - 7"	0 lb
P4) 24" - GRADE RING w/ConBlock-CDA Red F/F - 3"	202 lb
P3) 48" - CON CONE w/24" HOLE, w/ConBlock-CDA Red F/G - 24"	1297 lb
P2) 48" - MH RISER w/ConBlock-CDA Red T/G - 24"	1677 lb
P1) 48" - MH BASE w/ConBlock-CDA Red T/n - 30"	3330 lb
1) JOINT WRAP - 0.065"x12"x50' CONSEAL CS212	0 lb
1) JOINT WRAP PRIMER - CONSEAL CS-75 (1 gal.)	0 lb
1) ADMIXTURE CONBLOCK CDA RED	0 lb
1) 48" - MH INVERT CHANNEL w/ConBlock-CDA Red - FULL HEIGHT	1440 lb
1) CASTING - JBS 1150 F/C SANITARY	250 lb
2) 48" - Conseal CS-102 1.00" (Double)	0 lb
1) PSX - 12-08 NYLO	8 lb
1) PSX - 12M NYLO	8 lb
6) MH Step ML-10-TDS-NCR - 10"	0 lb
Structure Total:	8212 lb

- Structure Notes:**
- PER ASTM C-478 SPECIFICATIONS
 - CONCRETE: 4,000 PSI AT 28 DAYS
 - REINFORCEMENT: PER ASTM A615
 - INVERT CHANNEL REQUIRED
 - CONBLOCK CDA RED ADMIXTURE REQUIRED
 - STEPS AT 225 DEGREES
 - CASTING BY ICAST (JBS 1150 FRAME & COVER "SANITARY")

Rim: 544.1' Rim to Invert: 7.21' Slack: 0.52" Sump: 2" Step Position: 225°

Position	Elev	Angle	Ext. (cw)	Pipe	Pipe OD	Connector	Hole	Horz Size	Up ()	Offset
Invert 1	536.89'	0°	0"	8" PVC SDR35	8.5"	PSX 12-08 NYLO	12"	12.129"	0"	0"
Invert 2	537.09'	90°	45.553"	8" DI	9"	PSX 12M NYLO	12"	12.129"	2.4"	0"
Invert 3										
Invert 4										
Invert 5										
Invert 6										
Invert 7										
Invert 8										

RIGHT-SIDE UP VIEW (int. dimensions)

UPSIDE-DOWN VIEW (int. dimenions)

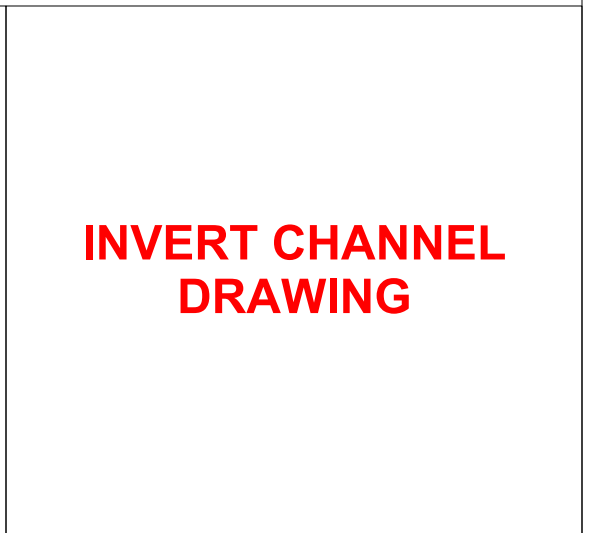
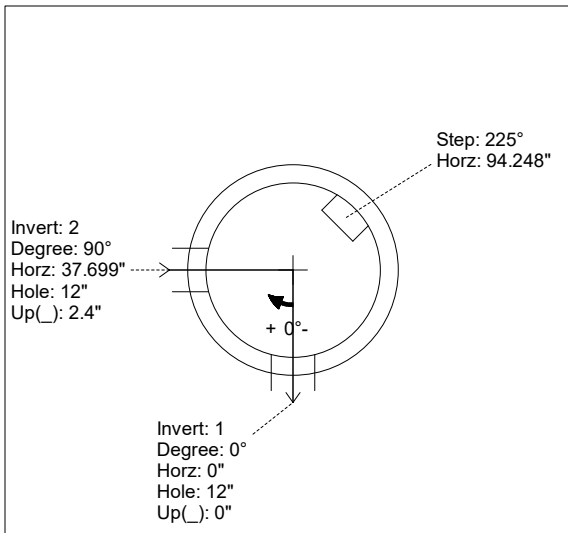
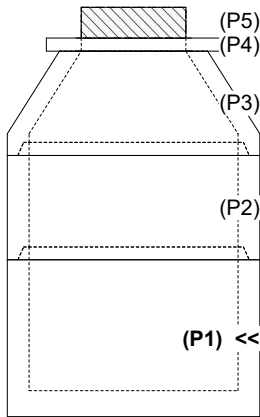

INSIDE WALL DIMENSIONS

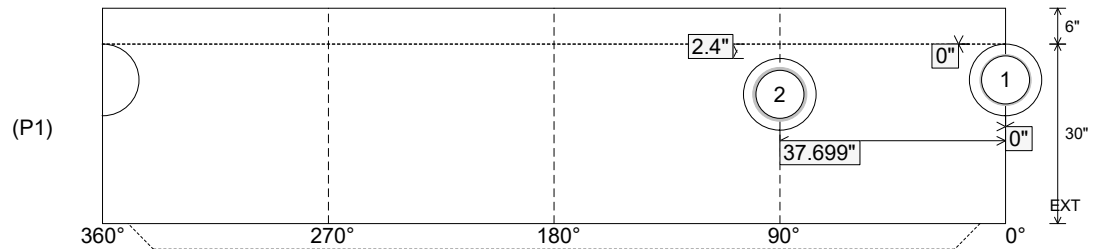

Coating (Int):
Coating (Ext):

Seam Up: Tongue
Seam Dn: n/a

Wall Thickness: 5"
Floor Height: 6"

Height (Int): 30"
Height (Ext): 36"

Weight (Net): 3330 lb
Volume (Net): 0.85cu.yd