

Job Name: 24-3539 - Larkin Springs Townhomes
Job Location: Nashville, TN
Contractor: Apex Earthworks, LLC

PC: A. Chambers
 TECH: J. Horsley - F
 Plant: 100



Structure ID: 3
 Spec: Sanitary
 Type: SAN.MH w/ConBlock-CDA Red
 Size: 48"

Rim: 536.5'
 Invert: 528.05'
 Rim to Invert: 8.45'

Sump: 2"
 Floor (Top): 527.883'
 Floor Height: 6"

Floor (Bot): 527.383'
 Overall Height: 9.083'
 Slack: 0.4"

- Structure Notes:**
1. PER ASTM C-478 SPECIFICATIONS
 2. CONCRETE: 4,000 PSI AT 28 DAYS
 3. REINFORCEMENT: PER ASTM A615
 4. INVERT CHANNEL REQUIRED
 5. CONBLOCK CDA RED ADMIXTURE REQUIRED
 6. STEPS AT 128.5 DEGREES
 7. CASTING BY ICAST (JBS 1150 FRAME & COVER "SANITARY")

STRUCTURE SUMMARY:

- P4) 24" - CASTING HEIGHT - 7" 0 lb
 - P3) 48" - CON CONE w/24" HOLE, w/ConBlock-CDA Red F/G - 36" 2251 lb
 - P2) 48" - MH RISER w/ConBlock-CDA Red T/G - 36" 2515 lb
 - P1) 48" - MH BASE w/ConBlock-CDA Red T/n - 24" 2911 lb
 - 1) JOINT WRAP - 0.065"x12"x50' CONSEAL CS212 0 lb
 - 1) JOINT WRAP PRIMER - CONSEAL CS-75 (1 gal.) 0 lb
 - 1) ADMIXTURE CONBLOCK CDA RED 0 lb
 - 1) 48" - MH INVERT CHANNEL w/ConBlock-CDA Red - FULL HEIGHT 1440 lb
 - 1) CASTING - JBS 1150 F/C SANITARY 250 lb
 - 2) 48" - Conseal CS-102 1.00" (Double) 0 lb
 - 2) PSX - 12-08 NYLO 16 lb
 - 8) MH Step ML-10-TDS-NCR - 10" 0 lb
- Structure Total: 9383 lb**

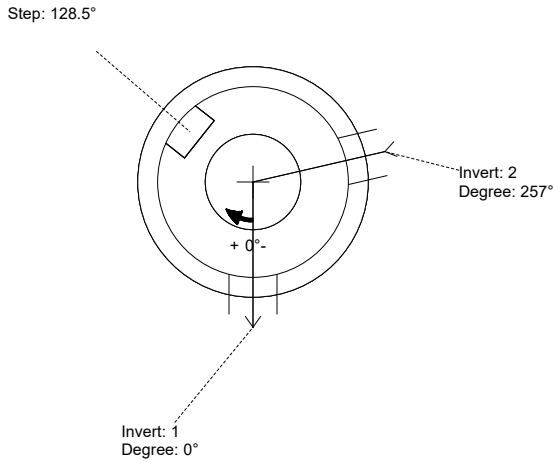

Position	Elev	Angle	Pipe	Pipe OD	Hole	Connector	Up (L)	Ref
Rim	536.5'							
Reducer								
Invert 1	528.05'	0°	8" PVC SDR35	8.5"	12"	PSX 12-08 NYLO	0"	P1
Invert 2	528.25'	257°	8" PVC SDR35	8.5"	12"	PSX 12-08 NYLO	2.4"	P1
Invert 3								
Invert 4								
Invert 5								
Invert 6								
Invert 7								
Invert 8								

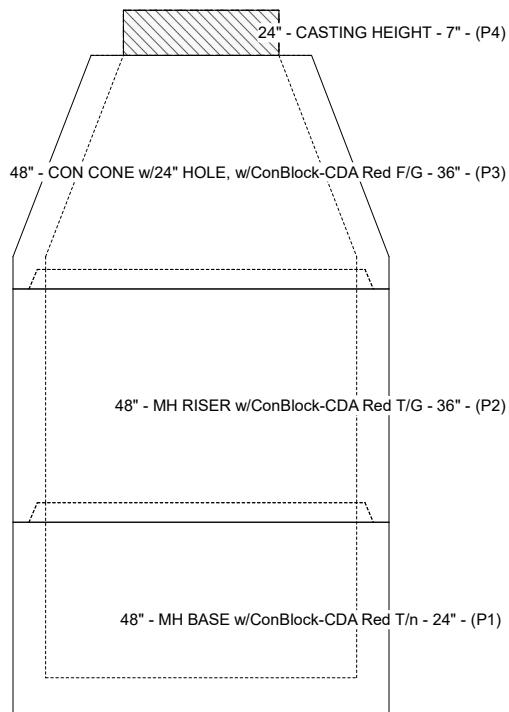

Cast (Int. Dim.) - Interior Dimensions

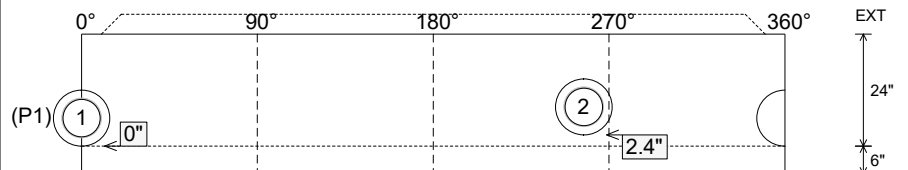

Submittal Drawing
 1/5/2026 10:04:24 AM

SUBMITTAL
 APPROVED BY: