

Job Name: 24-3539 - Larkin Springs Townhomes
Job Location: Nashville, TN
Contractor: Apex Earthworks, LLC

PC: A. Chambers
 TECH: J. Horsley - F
 Plant: 100



Structure ID: 1
 Spec: Sanitary
 Type: SAN.MH w/ConBlock-CDA Red
 Size: 48"

Rim: 530.2'
 Invert: 516.31'
 Rim to Invert: 13.89'

Sump: 2"
 Floor (Top): 516.143'
 Floor Height: 6"

Floor (Bot): 515.643'
 Overall Height: 14.417'
 Slack: 1.68"

Structure Notes:

- PER ASTM C-478 SPECIFICATIONS
- CONCRETE: 4,000 PSI AT 28 DAYS
- REINFORCEMENT: PER ASTM A615
- INVERT CHANNEL REQUIRED
- CONBLOCK CDA RED ADMIXTURE REQUIRED
- STEPS AT 242.5 DEGREES
- CASTING BY ICAST (JBS 1150 FRAME & COVER "SANITARY")

STRUCTURE SUMMARY:

- P6) 24" - CASTING HEIGHT - 7" 0 lb
 - P5) 24" - GRADE RING w/ConBlock-CDA Red F/F - 4" 270 lb
 - P4) 48" - CON CONE w/24" HOLE, w/ConBlock-CDA Red F/G - 36" 2251 lb
 - P3) 48" - MH RISER w/ConBlock-CDA Red T/G - 48" 3353 lb
 - P2) 48" - MH RISER w/ConBlock-CDA Red T/G - 48" 3353 lb
 - P1) 48" - MH BASE w/ConBlock-CDA Red T/n - 24" 2911 lb
 - 1) JOINT WRAP - 0.065"x12"x50' CONSEAL CS212 0 lb
 - 1) JOINT WRAP PRIMER - CONSEAL CS-75 (1 gal.) 0 lb
 - 1) ADMIXTURE CONBLOCK CDA RED 0 lb
 - 1) 48" - MH INVERT CHANNEL w/ConBlock-CDA Red - FULL HEIGHT 1440 lb
 - 1) CASTING - JBS 1150 F/C SANITARY 250 lb
 - 3) 48" - Conseal CS-102 1.00" (Double) 0 lb
 - 1) PSX - 12M NYLO 8 lb
 - 1) PSX - 12-08 NYLO 8 lb
 - 13) MH Step ML-10-TDS-NCR - 10" 0 lb
- Structure Total: 13845 lb

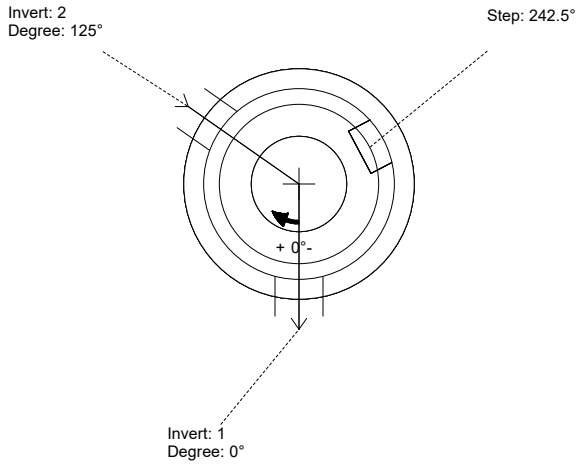

| Position | Elev | Angle | Pipe | Pipe OD | Hole | Connector | Up (L) | Ref |
|----------|---------|-------|--------------|---------|------|----------------|--------|-----|
| Rim | 530.2' | | | | | | | |
| Reducer | | | | | | | | |
| Invert 1 | 516.31' | 0° | 8" DI | 9" | 12" | PSX 12M NYLO | 0" | P1 |
| Invert 2 | 516.51' | 125° | 8" PVC SDR35 | 8.5" | 12" | PSX 12-08 NYLO | 2.4" | P1 |
| Invert 3 | | | | | | | | |
| Invert 4 | | | | | | | | |
| Invert 5 | | | | | | | | |
| Invert 6 | | | | | | | | |
| Invert 7 | | | | | | | | |
| Invert 8 | | | | | | | | |

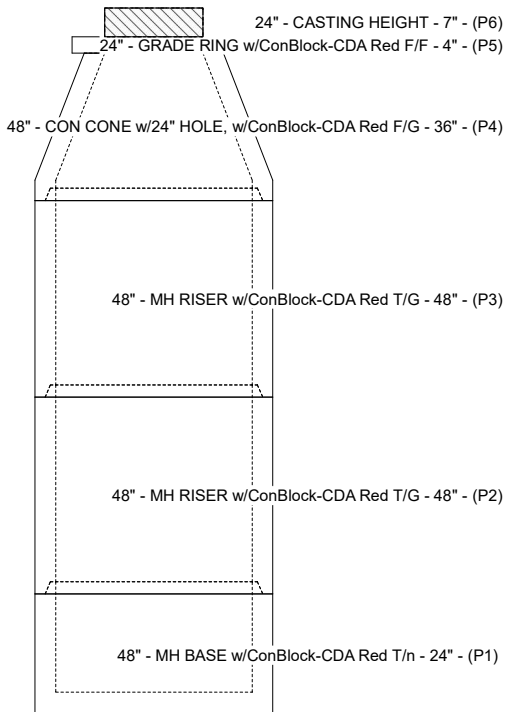

Cast (Int. Dim.) - Interior Dimensions

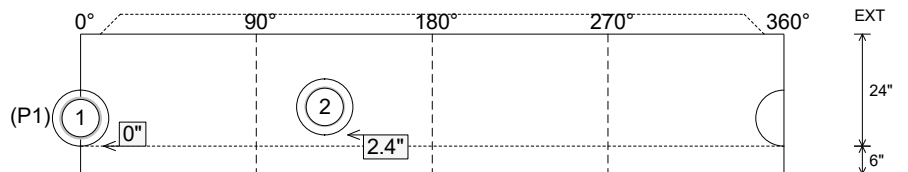

Submittal Drawing
 1/5/2026 10:04:22 AM

SUBMITTAL
 APPROVED BY: