

Job Name: 24-3511 Coles Ferry Section 18 & 19
 Job Location: Lebanon, TN
 Contractor: Covenant Constructors, LLC

Plant: Beaver Dam, KY
 2/23/2026 4:39:19 PM

Tech: J. Horsley
 PC: A. Chambers



Structure ID: SAMH D1

P1 MH048BAVFX

MH BASE Custom Ht, w/XYPEX T/n

- P3) 24" - CASTING HEIGHT - 6"
- P2) 48" - CON XYPEX CONE w/24" HOLE F/G - 24"
- P1) 48" - MH BASE Custom Ht, w/XYPEX T/n - 29"
- 1) 48" - MH INVERT CHANNEL w/XYPEX - FULL HEIGHT
- 1) JOINT WRAP - 0.065"x6"x50' CONSEAL CS212
- 1) JOINT WRAP PRIMER - CONSEAL CS-75 (1 gal.)
- 1) ADMIXTURE XYPEX C-500 NF RED
- 1) CASTING - JBS 1155 F/C SANITARY
- 1) 48" - DBL 1"x14.5' Butyl (2x)
- 1) Kor-N-Seal1 - S106-12AW
- 4) MH Step ML-10-TDS-NCR - 10"

0 lb
 2251 lb
 3308 lb
 1440 lb
 0 lb
 0 lb
 0 lb
 250 lb
 0 lb
 6 lb
 0 lb

 Structure Total: 7256 lb

Structure Notes:

1. PER ASTM C478 SPECIFICATIONS.
2. CONCRETE = 4,000 PSI AT 28 DAYS.
3. ADMIXTURE = XYPEX C-500 NF RED
3.5% BY WEIGHT OF CEMENT
4. CASTING BY ICAST (JBS 1155 F/C).

REINFORCING PER ASTM A615 (GRADE 60).

- CONE (As .12)
- RISER (As .12)
- FLOOR (As .31) #5 BARS AT 12" C.C.E.W.

Rim: 573.02' Rim to Invert: 4.76' Slack: 0.12' Sump: 2' Step Position: 180°

Position	Elev	Angle	Ext. (cw)	Pipe	Pipe OD	Connector	Hole	Horz Size	Up ()	Offset
Invert 1	568.26'	0°	0"	8" PVC SDR26	8.5"	Kor-N-Seal1 S106-12AW	12"	12.129"	0"	0"
Invert 2										
Invert 3										
Invert 4										
Invert 5										
Invert 6										
Invert 7										
Invert 8										

RIGHT-SIDE UP VIEW (int. dimensions)

UPSIDE-DOWN VIEW (int. dimensions)

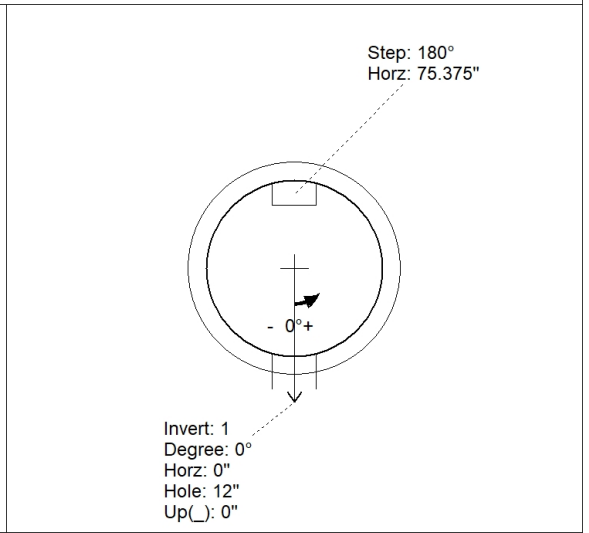
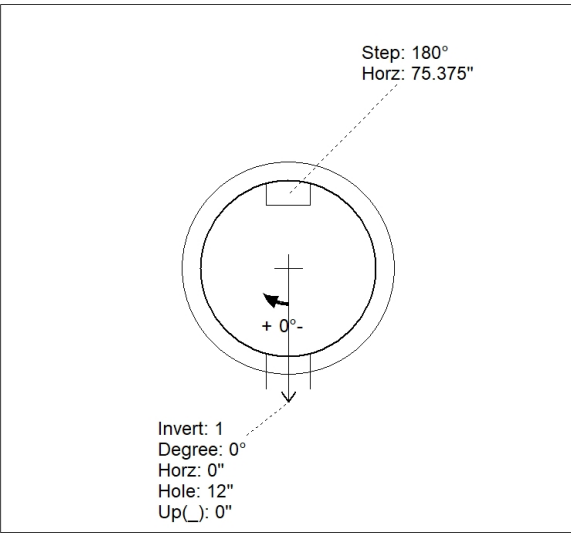
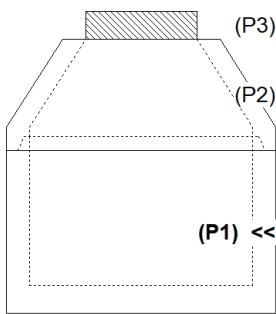

INSIDE WALL DIMENSIONS

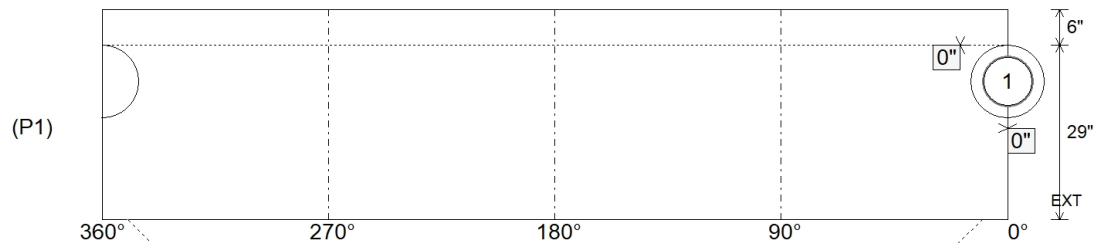

Coating (Int):
 Coating (Ext):

Seam Up: Tongue
 Seam Dn: n/a

Wall Thickness: 5"
 Floor Height: 6"

Height (Int): 29"
 Height (Ext): 35"

Weight (Net): 3308 lb
 Volume (Net): 0.84cu.yd

Job Name: 24-3511 Coles Ferry Section 18 & 19
 Job Location: Lebanon, TN
 Contractor: Covenant Constructors, LLC

Plant: Beaver Dam, KY
 2/23/2026 4:39:19 PM

Tech: J. Horsley
 PC: A. Chambers



Structure ID: SAMH D1

P1A MH048BAVFX

MH BASE Custom Ht, w/YYPEX T/n

- P3) 24" - CASTING HEIGHT - 6"
- P2) 48" - CON XYPEX CONE w/24" HOLE F/G - 24"
- P1) 48" - MH BASE Custom Ht, w/YYPEX T/n - 29"
- 1) 48" - MH INVERT CHANNEL w/YYPEX - FULL HEIGHT
- 1) JOINT WRAP - 0.065"x6"x50' CONSEAL CS212
- 1) JOINT WRAP PRIMER - CONSEAL CS-75 (1 gal.)
- 1) ADMIXTURE XYPEX C-500 NF RED
- 1) CASTING - JBS 1155 F/C SANITARY
- 1) 48" - DBL 1"x14.5' Butyl (2x)
- 1) Kor-N-Seal1 - S106-12AW
- 4) MH Step ML-10-TDS-NCR - 10"

0 lb
 2251 lb
 3308 lb
 1440 lb
 0 lb
 0 lb
 0 lb
 250 lb
 0 lb
 6 lb
 0 lb

 Structure Total: 7256 lb

Structure Notes:

1. PER ASTM C478 SPECIFICATIONS.
2. CONCRETE = 4,000 PSI AT 28 DAYS.
3. ADMIXTURE = XYPEX C-500 NF RED
3.5% BY WEIGHT OF CEMENT
4. CASTING BY ICAST (JBS 1155 F/C).

REINFORCING PER ASTM A615 (GRADE 60).
 - CONE (As .12)
 - RISER (As .12)
 - FLOOR (As .31) #5 BARS AT 12" C.C.E.W.

Rim: 573.02' Rim to Invert: 4.76' Slack: 0.12' Sump: 2' Step Position: 180°

Position	Elev	Angle	Ext. (cw)	Pipe	Pipe OD	Connector	Hole	Horz Size	Up ()	Offset
Invert 1	568.26'	0°	0"	8" PVC SDR26	8.5"	Kor-N-Seal1 S106-12AW	12"	12.129"	0"	0"
Invert 2										
Invert 3										
Invert 4										
Invert 5										
Invert 6										
Invert 7										
Invert 8										

RIGHT-SIDE UP VIEW (int. dimensions)

UPSIDE-DOWN VIEW (int. dimensions)

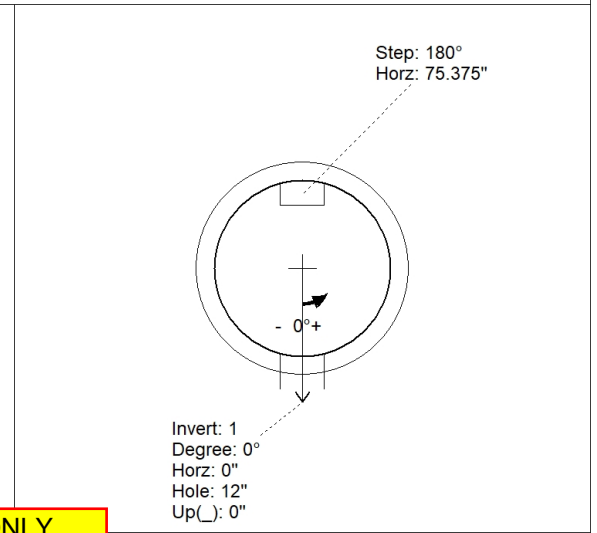
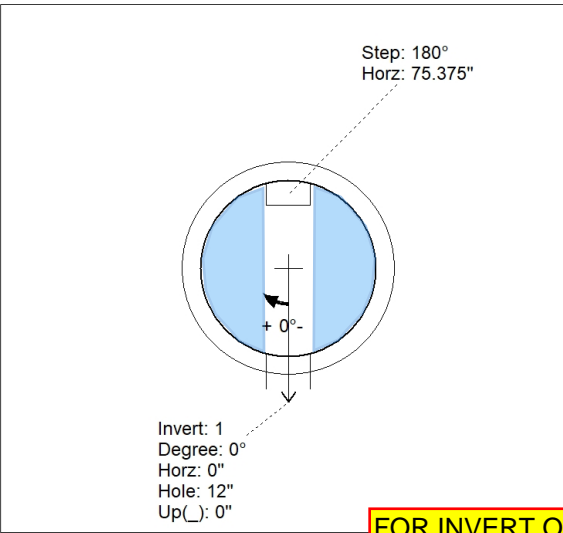
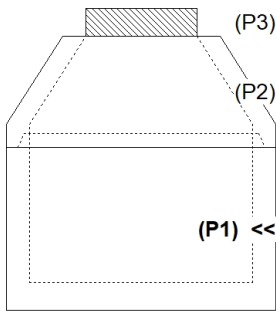

INSIDE WALL DIMENSIONS

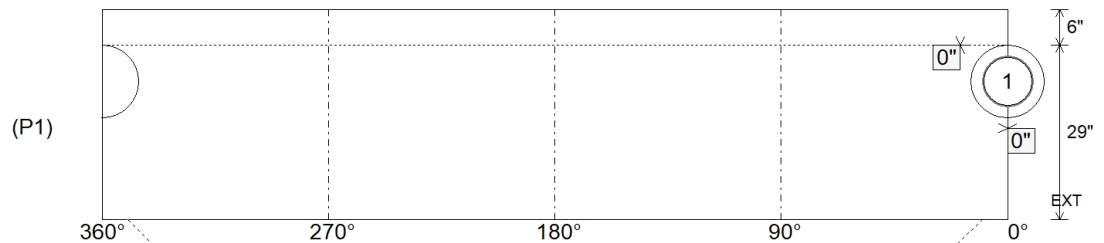

Coating (Int):
 Coating (Ext):

Seam Up: Tongue
 Seam Dn: n/a

Wall Thickness: 5"
 Floor Height: 6"

Height (Int): 29"
 Height (Ext): 35"

Weight (Net): 3308 lb
 Volume (Net): 0.84cu.yd