

**Job Name: 24-3511 Coles Ferry Section 18 & 19**  
**Job Location: Lebanon, TN**  
**Contractor: Covenant Constructors, LLC**

PC: A. Chambers  
 TECH: J. Horsley  
 Plant: Beaver Dam, KY



Structure ID: **SAMH C2**

Spec: Sanitary  
 Type: SAN.MH w/Xypex  
 Size: 48"

Rim: 572.36'  
 Invert: 565.5'  
 Rim to Invert: 6.86'

Sump: 2"  
 Floor (Top): 565.333'  
 Floor Height: 6"

Floor (Bot): 564.833'  
 Overall Height: 7.5'  
 Slack: 0.32"

**Structure Notes:**

1. PER ASTM C478 SPECIFICATIONS.
2. CONCRETE = 4,000 PSI AT 28 DAYS.
3. ADMIXTURE = XYPEX C-500 NF RED 3.5% BY WEIGHT OF CEMENT
4. CASTING BY ICAST (JBS 1155 F/C).

REINFORCING PER ASTM A615 (GRADE 60).  
 - CONE (As .12)  
 - RISER (As .12)  
 - FLOOR (As .31) #5 BARS AT 12" C.C.E.W.

**STRUCTURE SUMMARY:**

P4) 24" - CASTING HEIGHT - 6"	0 lb
P3) 48" - CON XYPEX CONE w/24" HOLE F/G - 24"	2251 lb
P2) 48" - MH RISER w/XYPEX T/G - 24"	1677 lb
P1) 48" - MH BASE w/XYPEX T/n - 30"	3330 lb
1) 48" - MH INVERT CHANNEL w/XYPEX - FULL HEIGHT	1440 lb
1) JOINT WRAP - 0.065"x6"x50' CONSEAL CS212	0 lb
1) JOINT WRAP PRIMER - CONSEAL CS-75 (1 gal.)	0 lb
1) ADMIXTURE XYPEX C-500 NF RED	0 lb
1) CASTING - JBS 1155 F/C SANITARY	250 lb
2) 48" - DBL 1"x14.5' Butyl (2x)	0 lb
2) Kor-N-Seal1 - S106-12AW	13 lb
6) MH Step ML-10-TDS-NCR - 10"	0 lb
<b>Structure Total:</b>	<b>8961 lb</b>

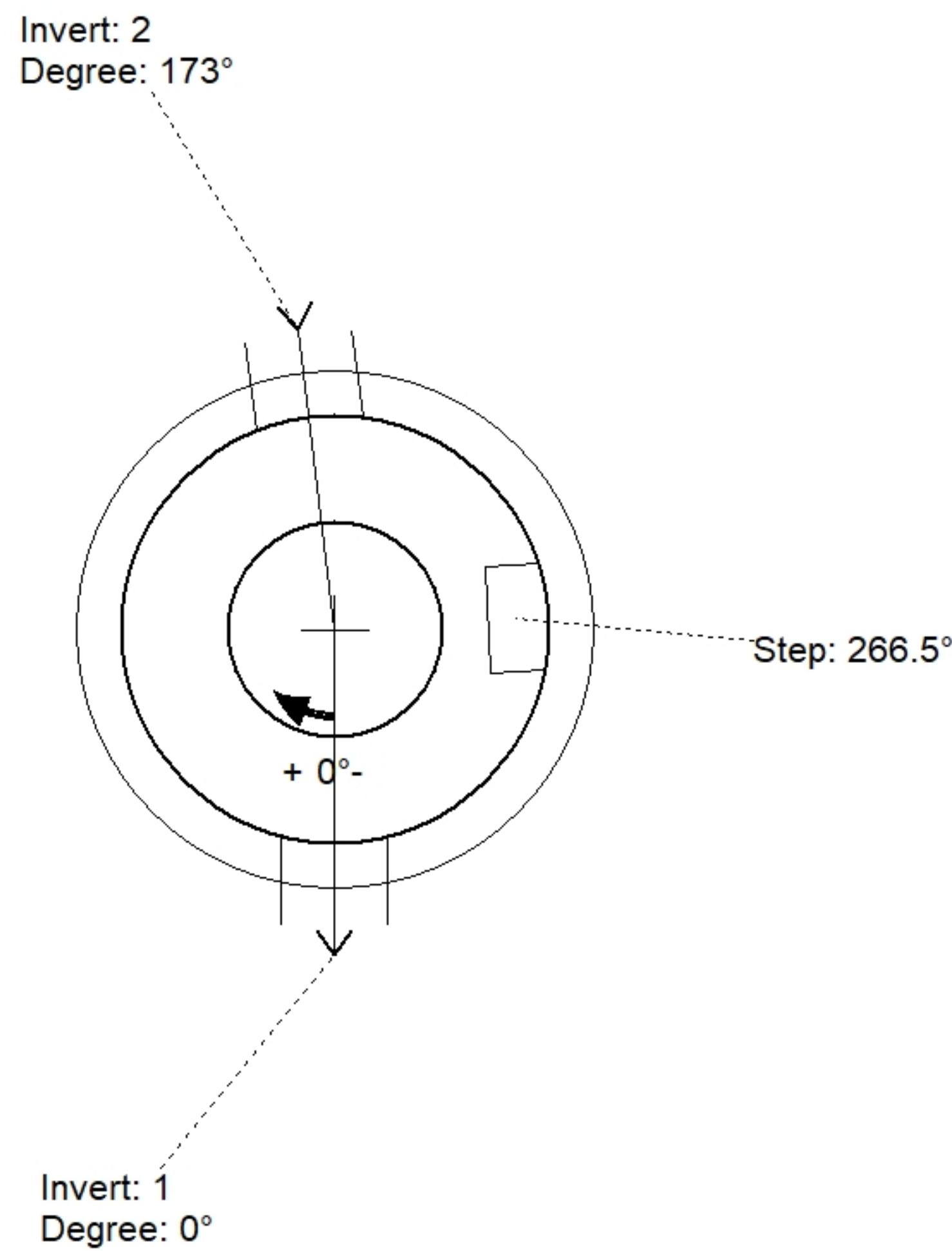

Position	Elev	Angle	Pipe	Pipe OD	Hole	Connector	Up (")	Ref
Rim	572.36'							
Reducer								
Invert 1	565.5'	0°	8" PVC SDR26	8.5"	12"	Kor-N-Seal1 S106-12AW	0"	P1
Invert 2	565.6'	173°	8" PVC SDR26	8.5"	12"	Kor-N-Seal1 S106-12AW	1.25"	P1
Invert 3								
Invert 4								
Invert 5								
Invert 6								
Invert 7								
Invert 8								

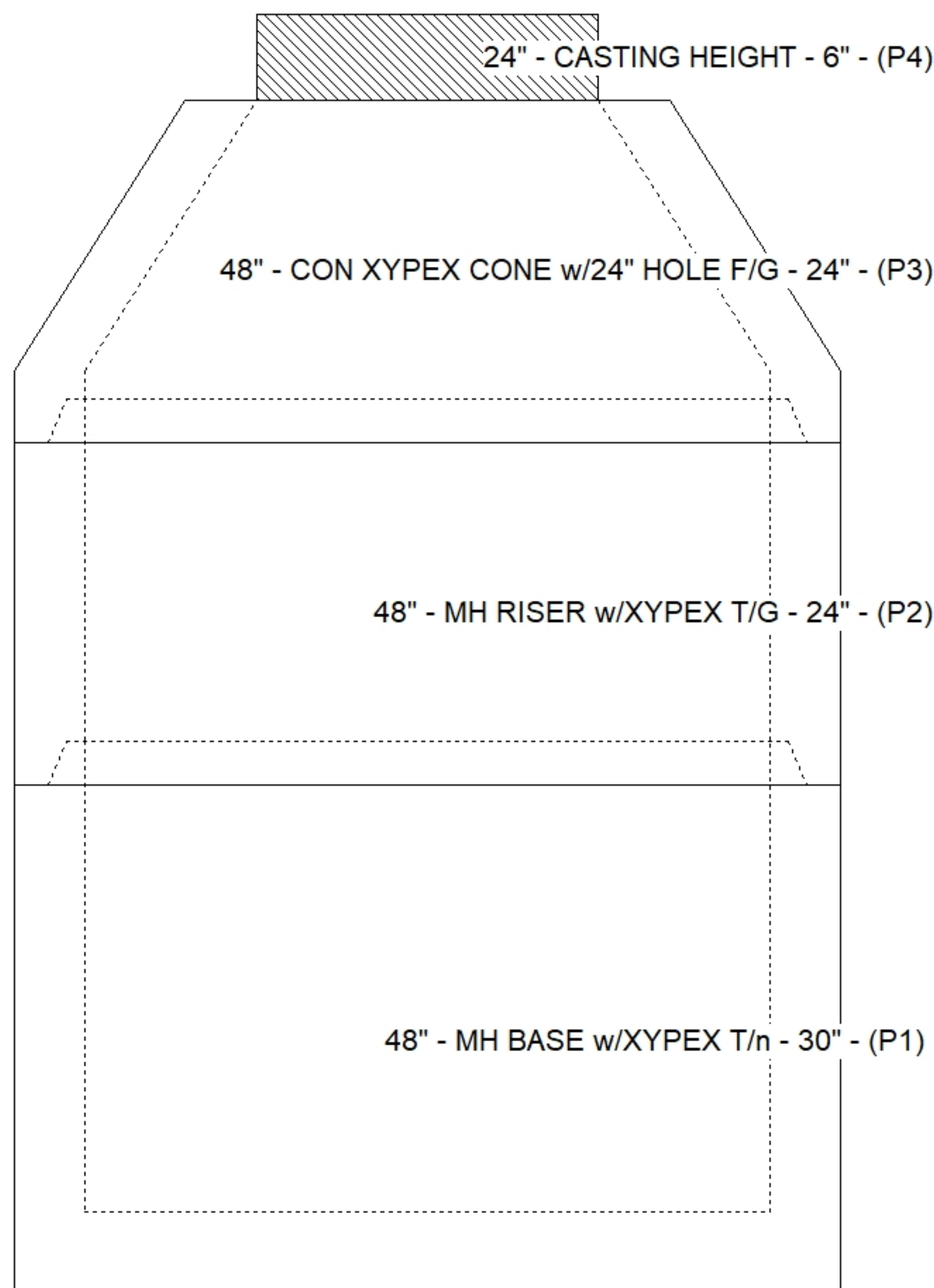

**Cast (Int. Dim.) - Interior Dimensions**

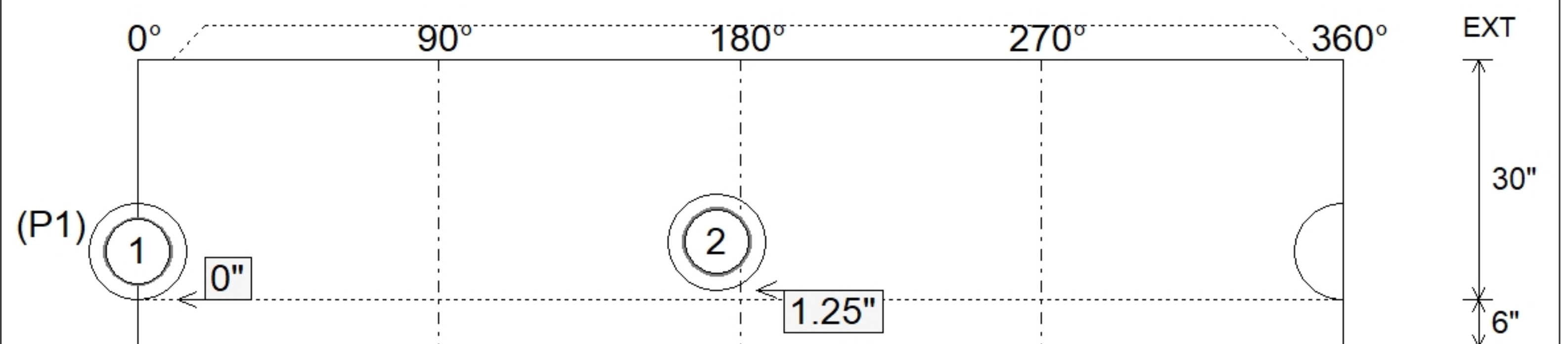

Submittal Drawing  
 2/23/2026 4:38:35 PM

SUBMITTAL  
 APPROVED BY: