

Job Name: 24-3511 Coles Ferry Section 18 & 19
 Job Location: Lebanon, TN
 Contractor: Covenant Constructors, LLC

Plant: Beaver Dam, KY
 2/23/2026 4:39:19 PM

Tech: J. Horsley
 PC: A. Chambers



Structure ID: SAMH C2

P1 MH048BA30X

MH BASE w/XYPEX T/n

- P4) 24" - CASTING HEIGHT - 6"
- P3) 48" - CON XYPEX CONE w/24" HOLE F/G - 24"
- P2) 48" - MH RISER w/XYPEX T/G - 24"
- P1) 48" - MH BASE w/XYPEX T/n - 30"
- 1) 48" - MH INVERT CHANNEL w/XYPEX - FULL HEIGHT
- 1) JOINT WRAP - 0.065"x6"x50' CONSEAL CS212
- 1) JOINT WRAP PRIMER - CONSEAL CS-75 (1 gal.)
- 1) ADMIXTURE XYPEX C-500 NF RED
- 1) CASTING - JBS 1155 F/C SANITARY
- 2) 48" - DBL 1"x14.5' Butyl (2x)
- 2) Kor-N-Seal1 - S106-12AW
- 6) MH Step ML-10-TDS-NCR - 10"

0 lb
 2251 lb
 1677 lb
 3330 lb
 1440 lb
 0 lb
 0 lb
 0 lb
 250 lb
 0 lb
 13 lb
 0 lb

 Structure Total: 8961 lb

Structure Notes:
 1. PER ASTM C478 SPECIFICATIONS.
 2. CONCRETE = 4,000 PSI AT 28 DAYS.
 3. ADMIXTURE = XYPEX C-500 NF RED 3.5% BY WEIGHT OF CEMENT
 4. CASTING BY ICAST (JBS 1155 F/C).

 REINFORCING PER ASTM A615 (GRADE 60).
 - CONE (As .12)
 - RISER (As .12)
 - FLOOR (As .31) #5 BARS AT 12" C.C.E.W.

Rim: 572.36' Rim to Invert: 6.86' Slack: 0.32" Sump: 2" Step Position: 266.5°

Position	Elev	Angle	Ext. (cw)	Pipe	Pipe OD	Connector	Hole	Horz Size	Up (↓)	Offset
Invert 1	565.5'	0°	0"	8" PVC SDR26	8.5"	Kor-N-Seal1 S106-12AW	12"	12.129"	0"	0"
Invert 2	565.6'	173°	87.625"	8" PVC SDR26	8.5"	Kor-N-Seal1 S106-12AW	12"	12.129"	1.25"	0"
Invert 3										
Invert 4										
Invert 5										
Invert 6										
Invert 7										
Invert 8										

RIGHT-SIDE UP VIEW (int. dimensions)

UPSIDE-DOWN VIEW (int. dimensions)

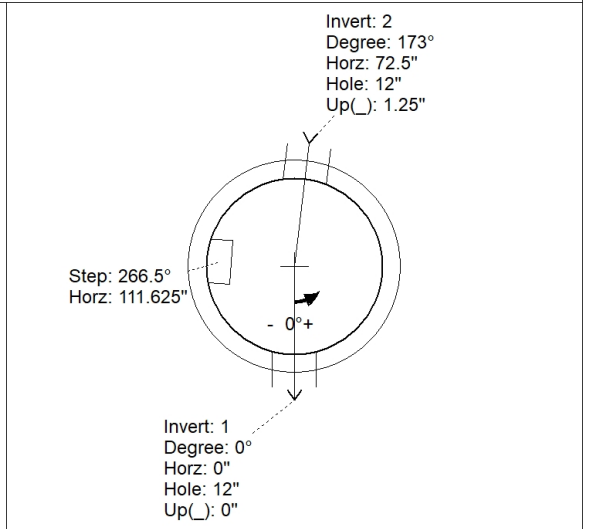
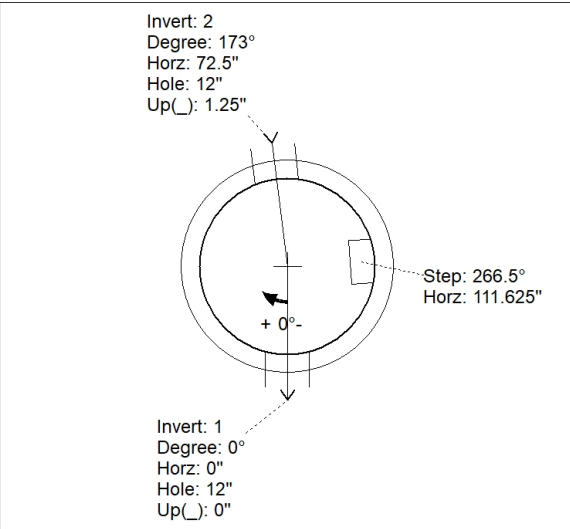
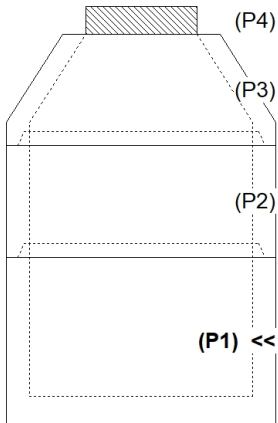

INSIDE WALL DIMENSIONS

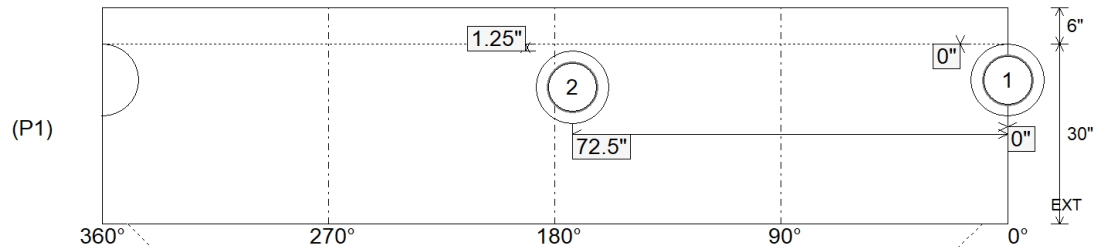

Coating (Int):
 Coating (Ext):

Seam Up: Tongue
 Seam Dn: n/a

Wall Thickness: 5"
 Floor Height: 6"

Height (Int): 30"
 Height (Ext): 36"

Weight (Net): 3330 lb
 Volume (Net): 0.85cu.yd

Job Name: 24-3511 Coles Ferry Section 18 & 19
 Job Location: Lebanon, TN
 Contractor: Covenant Constructors, LLC

Plant: Beaver Dam, KY
 2/23/2026 4:39:19 PM

Tech: J. Horsley
 PC: A. Chambers



Structure ID: SAMH C2

P1A MH048BA30X

MH BASE w/XYPEX T/n

- P4) 24" - CASTING HEIGHT - 6"
- P3) 48" - CON XYPEX CONE w/24" HOLE F/G - 24"
- P2) 48" - MH RISER w/XYPEX T/G - 24"
- P1) 48" - MH BASE w/XYPEX T/n - 30"
- 1) 48" - MH INVERT CHANNEL w/XYPEX - FULL HEIGHT
- 1) JOINT WRAP - 0.065"x6"x50' CONSEAL CS212
- 1) JOINT WRAP PRIMER - CONSEAL CS-75 (1 gal.)
- 1) ADMIXTURE XYPEX C-500 NF RED
- 1) CASTING - JBS 1155 F/C SANITARY
- 2) 48" - DBL 1"x14.5' Butyl (2x)
- 2) Kor-N-Seal1 - S106-12AW
- 6) MH Step ML-10-TDS-NCR - 10"

0 lb
 2251 lb
 1677 lb
 3330 lb
 1440 lb
 0 lb
 0 lb
 0 lb
 250 lb
 0 lb
 13 lb
 0 lb

 Structure Total: 8961 lb

Structure Notes:
 1. PER ASTM C478 SPECIFICATIONS.
 2. CONCRETE = 4,000 PSI AT 28 DAYS.
 3. ADMIXTURE = XYPEX C-500 NF RED 3.5% BY WEIGHT OF CEMENT
 4. CASTING BY ICAST (JBS 1155 F/C).

 REINFORCING PER ASTM A615 (GRADE 60).
 - CONE (As .12)
 - RISER (As .12)
 - FLOOR (As .31) #5 BARS AT 12" C.C.E.W.

Rim: 572.36' Rim to Invert: 6.86' Slack: 0.32" Sump: 2" Step Position: 266.5°

Position	Elev	Angle	Ext. (cw)	Pipe	Pipe OD	Connector	Hole	Horz Size	Up (↓)	Offset
Invert 1	565.5'	0°	0"	8" PVC SDR26	8.5"	Kor-N-Seal1 S106-12AW	12"	12.129"	0"	0"
Invert 2	565.6'	173°	87.625"	8" PVC SDR26	8.5"	Kor-N-Seal1 S106-12AW	12"	12.129"	1.25"	0"
Invert 3										
Invert 4										
Invert 5										
Invert 6										
Invert 7										
Invert 8										

RIGHT-SIDE UP VIEW (int. dimensions)

UPSIDE-DOWN VIEW (int. dimensions)

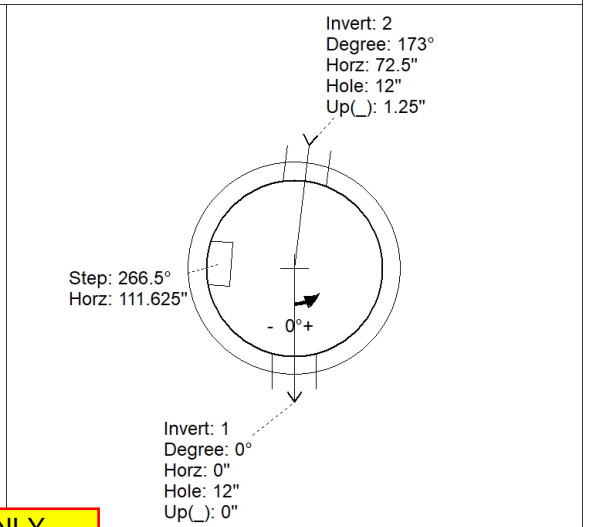
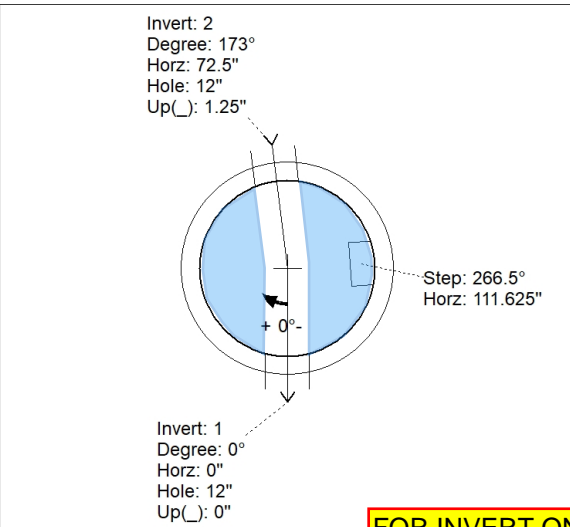
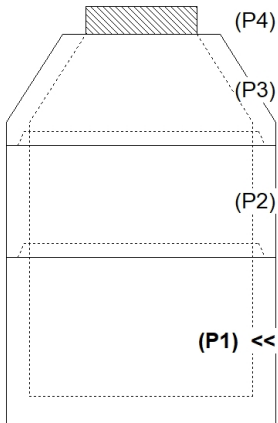

FOR INVERT ONLY

INSIDE WALL DIMENSIONS

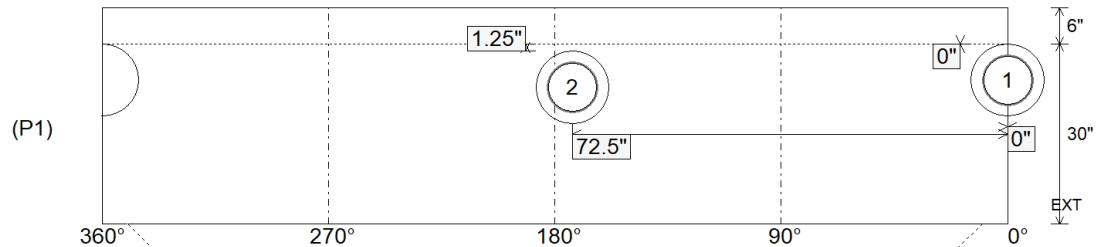

Coating (Int): Coating (Ext):	Seam Up: Tongue Seam Dn: n/a	Wall Thickness: 5" Floor Height: 6"	Height (Int): 30" Height (Ext): 36"	Weight (Net): 3330 lb Volume (Net): 0.85cu.yd
----------------------------------	---------------------------------	--	--	--