

Job Name: 24-3511 Coles Ferry Section 18 & 19	Plant: Beaver Dam, KY	Tech: J. Horsley	
Job Location: Lebanon, TN Contractor: Covenant Constructors, LLC	2/23/2026 4:40:45 PM	PC: A. Chambers	

Structure ID: SAMH C1
P2 MH048CCN36X CON XYPEX CONE w/24" HOLE F/G

P3) 24" - CASTING HEIGHT - 6"	0 lb
P2) 48" - CON XYPEX CONE w/24" HOLE F/G - 36"	2251 lb
P1) 48" - MH BASE Custom Ht, w/XYPEX T/n - 41"	4099 lb
1) 48" - MH INVERT CHANNEL w/XYPEX - FULL HEIGHT	1440 lb
1) JOINT WRAP - 0.085"x8"x50' CONSEAL CS212	0 lb
1) JOINT WRAP PRIMER - CONSEAL CS-75 (1 gal.)	0 lb
1) ADMIXTURE XYPEX C-500 NF RED	0 lb
1) CASTING - JBS 1155 F/C SANITARY	250 lb
1) 48" - DBL 1"x14.5' Butyl (2x)	0 lb
2) Kor-N-Seal1 - S108-12AW	13 lb
6) MH Step ML-10-TDS-NCR - 10"	0 lb
Structure Total:	8053 lb

Structure Notes:

- PER ASTM C478 SPECIFICATIONS.
- CONCRETE = 4,000 PSI AT 28 DAYS.
- ADMIXTURE = XYPEX C-500 NF RED 3.5% BY WEIGHT OF CEMENT
- CASTING BY ICAST (JBS 1155 F/C).

REINFORCING PER ASTM A615 (GRADE 60).

- CONE (As .12)
- RISER (As .12)
- FLOOR (As .31) #5 BARS AT 12" C.C.E.W.

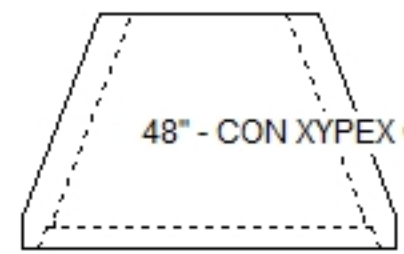
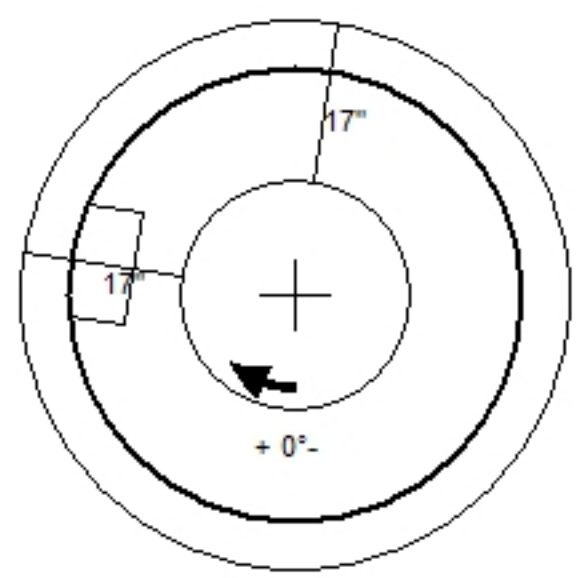

48" - CON XYPEX CONE w/24" HOLE F/G - 36" - (P2)

Coating (Int): Coating (Ext):	Seam Up: Flat Seam Dn: Groove	Wall Thickness: 5"	Height (Ext): 36"	Weight (Net): 2251 lb Volume (Net): 0.57cu.yd
----------------------------------	----------------------------------	--------------------	-------------------	--