

Structure ID: SAMH B3

P2 MH048RS36X

MH RISER w/XYPEX T/G

P4) 24" - CASTING HEIGHT - 6" P3) 48" - CON XYPEX CONE w/24" HOLE F/G - 24" P2) 48" - MH RISER w/XYPEX T/G - 36" P1) 48" - MH BASE Custom Ht, w/XYPEX T/n - 26" 1) 48" - MH INVERT CHANNEL w/XYPEX - FULL HEIGHT 1) JOINT WRAP - 0.065"x6"x50' CONSEAL CS212 1) JOINT WRAP PRIMER - CONSEAL CS-75 (1 gal.) 1) ADMIXTURE XYPEX C-500 NF RED 1) CASTING - JBS 1155 F/C SANITARY 2) 48" - DBL 1"x14.5' Butyl (2x) 1) Kor-N-Seal1 - S106-12AW 7) MH Step ML-10-TDS-NCR - 10"	0 lb 2251 lb 2515 lb 3099 lb 1440 lb 0 lb 0 lb 0 lb 250 lb 0 lb 6 lb 0 lb <hr style="width: 50px; margin-left: 0;"/> Structure Total: 9561 lb
---	---

Structure Notes:

1. PER ASTM C478 SPECIFICATIONS.
2. CONCRETE = 4,000 PSI AT 28 DAYS.
3. ADMIXTURE = XYPEX C-500 NF RED 3.5% BY WEIGHT OF CEMENT
4. CASTING BY ICAST (JBS 1155 F/C).

REINFORCING PER ASTM A615 (GRADE 60).

- CONE (As .12)
- RISER (As .12)
- FLOOR (As .31) #5 BARS AT 12" C.C.E.W.

Rim: 582.26' Rim to Invert: 7.53' Slack: 0.36" Sump: 2" Step Position: 180°

Position	Elev	Angle	Ext. (cw)	Pipe	Pipe OD	Connector	Hole	Horz Size	Up (L)	Offset
Invert 1										
Invert 2										
Invert 3										
Invert 4										
Invert 5										
Invert 6										
Invert 7										
Invert 8										

RIGHT-SIDE UP VIEW (int. dimensions)

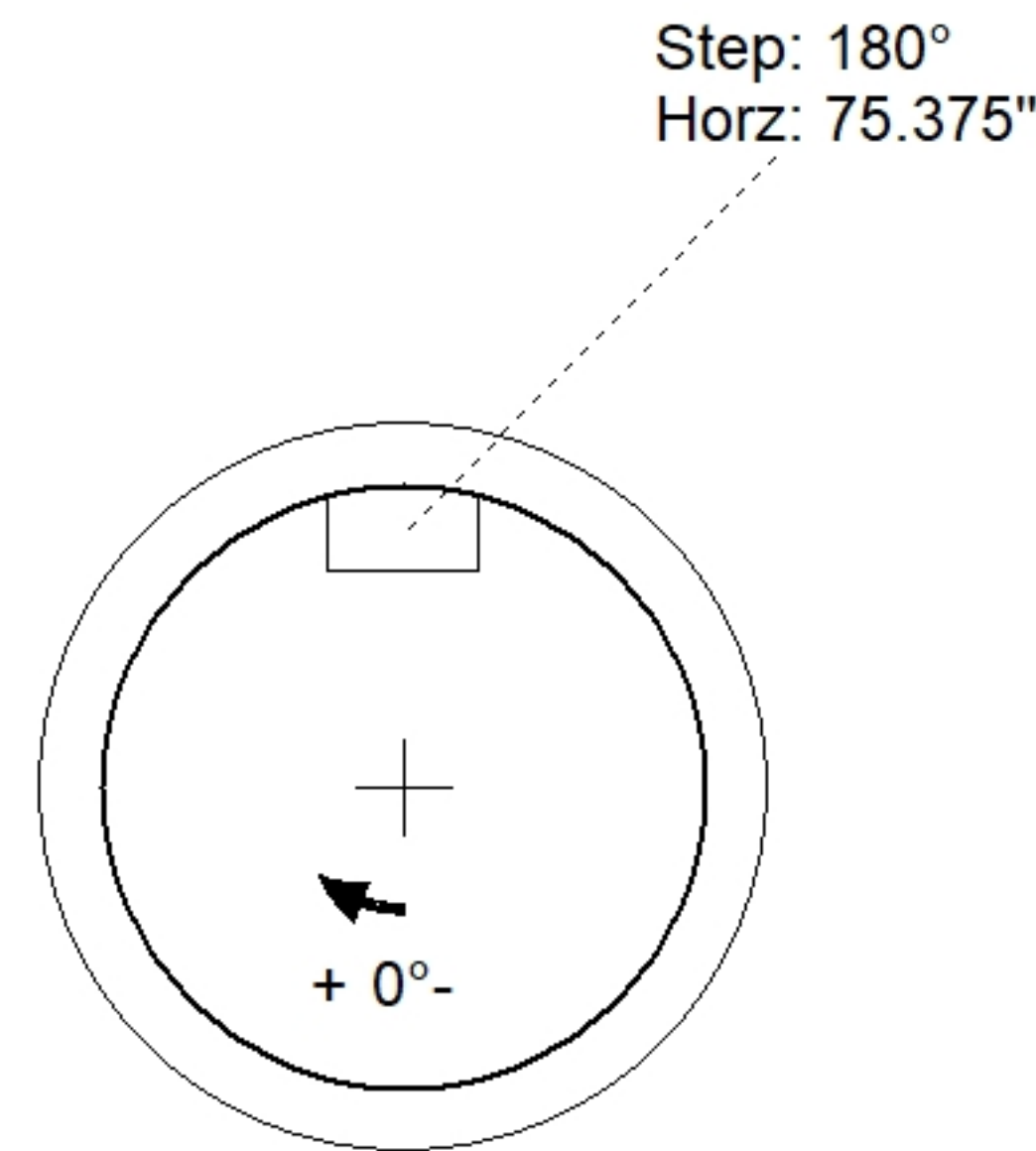
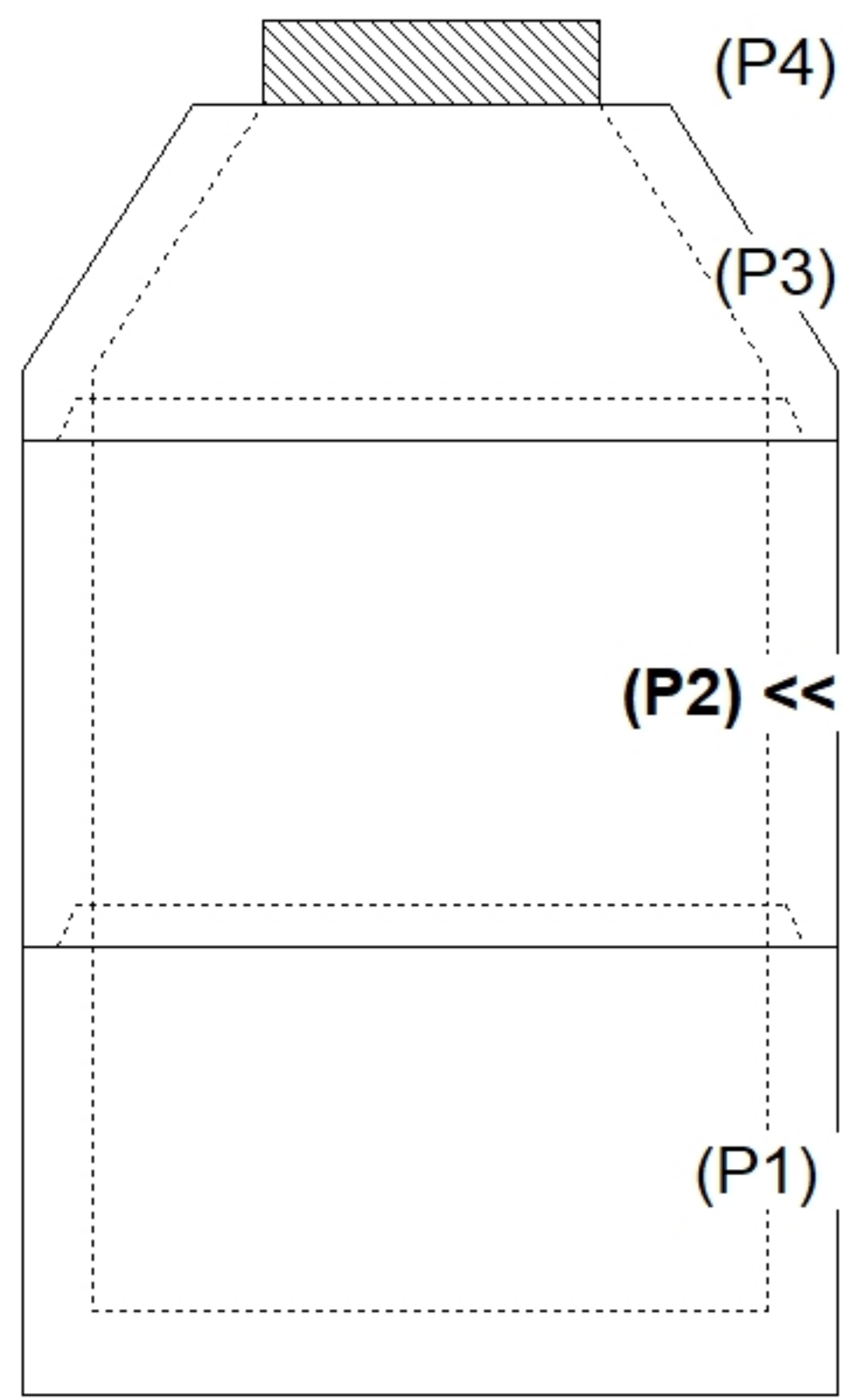

INSIDE WALL DIMENSIONS

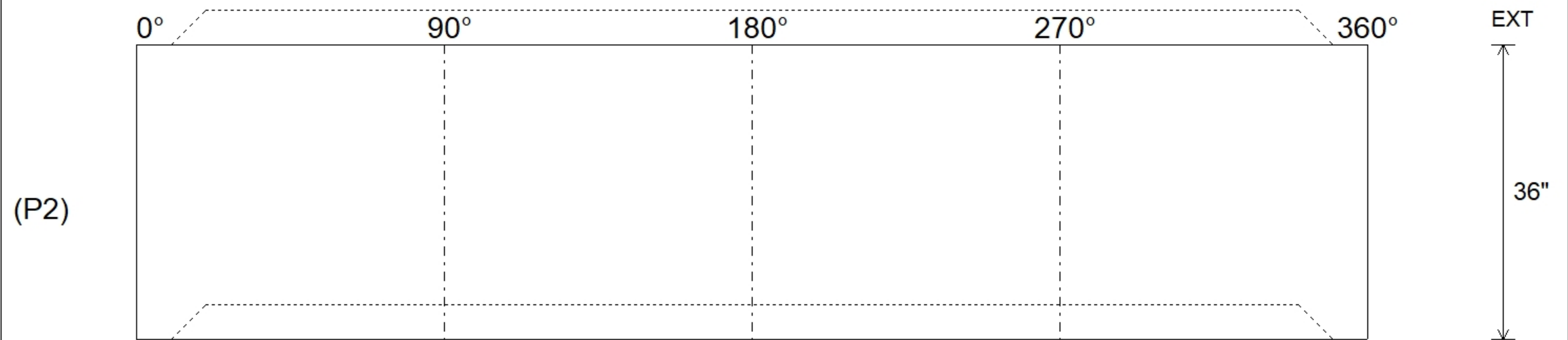

Coating (Int): Coating (Ext):	Seam Up: Tongue Seam Dn: Groove	Wall Thickness: 5" Floor Height: 0"	Height (Int): 36" Height (Ext): 36"	Weight (Net): 2515 lb Volume (Net): 0.64cu.yd
----------------------------------	------------------------------------	--	--	--