

Job Name: 24-3511 Coles Ferry Section 18 & 19
Job Location: Lebanon, TN
Contractor: Covenant Constructors, LLC

PC: A. Chambers
 TECH: J. Horsley
 Plant: Beaver Dam, KY



Structure ID: **SAMH B1**

Spec: Sanitary
 Type: SAN.MH w/Xypex
 Size: 48"

Rim: 574.46'
 Invert: 567.67'
 Rim to Invert: 6.79'

Sump: 2"
 Floor (Top): 567.503'
 Floor Height: 6"

Floor (Bot): 567.003'
 Overall Height: 7.417'
 Slack: 0.48"

Structure Notes:

1. PER ASTM C478 SPECIFICATIONS.
2. CONCRETE = 4,000 PSI AT 28 DAYS.
3. ADMIXTURE = XYPEX C-500 NF RED
3.5% BY WEIGHT OF CEMENT
4. CASTING BY ICAST (JBS 1155 F/C).

REINFORCING PER ASTM A615 (GRADE 60).
 - CONE (As .12)
 - RISER (As .12)
 - FLOOR (As .31) #5 BARS AT 12" C.C.E.W.

STRUCTURE SUMMARY:

P3) 24" - CASTING HEIGHT - 6"	0 lb
P2) 48" - CON XYPEX CONE w/24" HOLE F/G - 36"	2251 lb
P1) 48" - MH BASE Custom Ht, w/XYPEX T/n - 41"	4051 lb
1) 48" - MH INVERT CHANNEL w/XYPEX - FULL HEIGHT	1440 lb
1) JOINT WRAP - 0.065"x6"x50' CONSEAL CS212	0 lb
1) JOINT WRAP PRIMER - CONSEAL CS-75 (1 gal.)	0 lb
1) ADMIXTURE XYPEX C-500 NF RED	0 lb
1) CASTING - JBS 1155 F/C SANITARY	250 lb
1) 48" - DBL 1"x14.5' Butyl (2x)	0 lb
3) Kor-N-Seal1 - S106-12AW	20 lb
6) MH Step ML-10-TDS-NCR - 10"	0 lb
Structure Total:	8011 lb

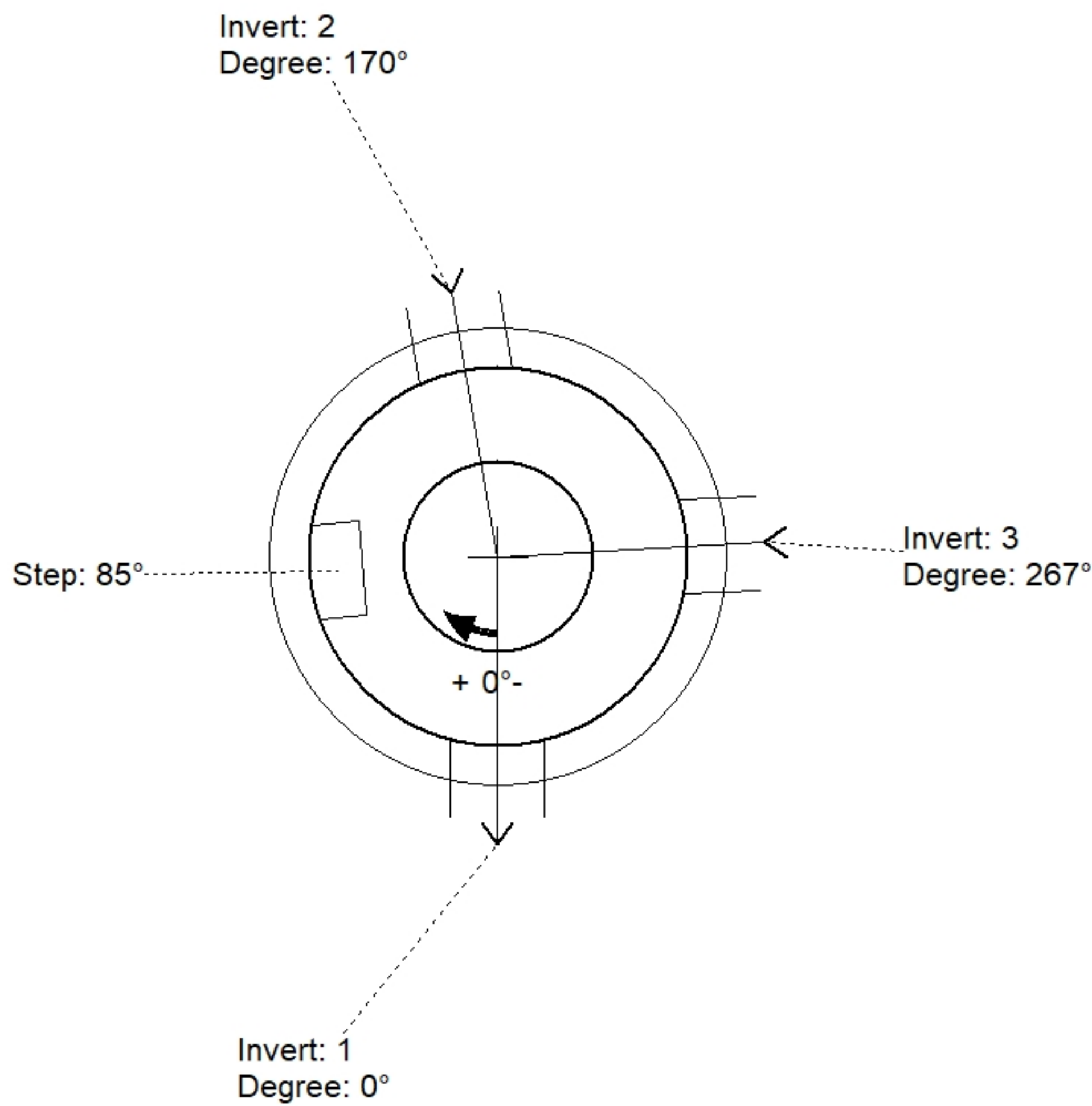

Position	Elev	Angle	Pipe	Pipe OD	Hole	Connector	Up (")	Ref
Rim	574.46'							
Reducer								
Invert 1	567.67'	0°	8" PVC SDR26	8.5"	12"	Kor-N-Seal1 S106-12AW	0"	P1
Invert 2	567.77'	170°	8" PVC SDR26	8.5"	12"	Kor-N-Seal1 S106-12AW	1.25"	P1
Invert 3	567.77'	267°	8" PVC SDR26	8.5"	12"	Kor-N-Seal1 S106-12AW	1.25"	P1
Invert 4								
Invert 5								
Invert 6								
Invert 7								
Invert 8								

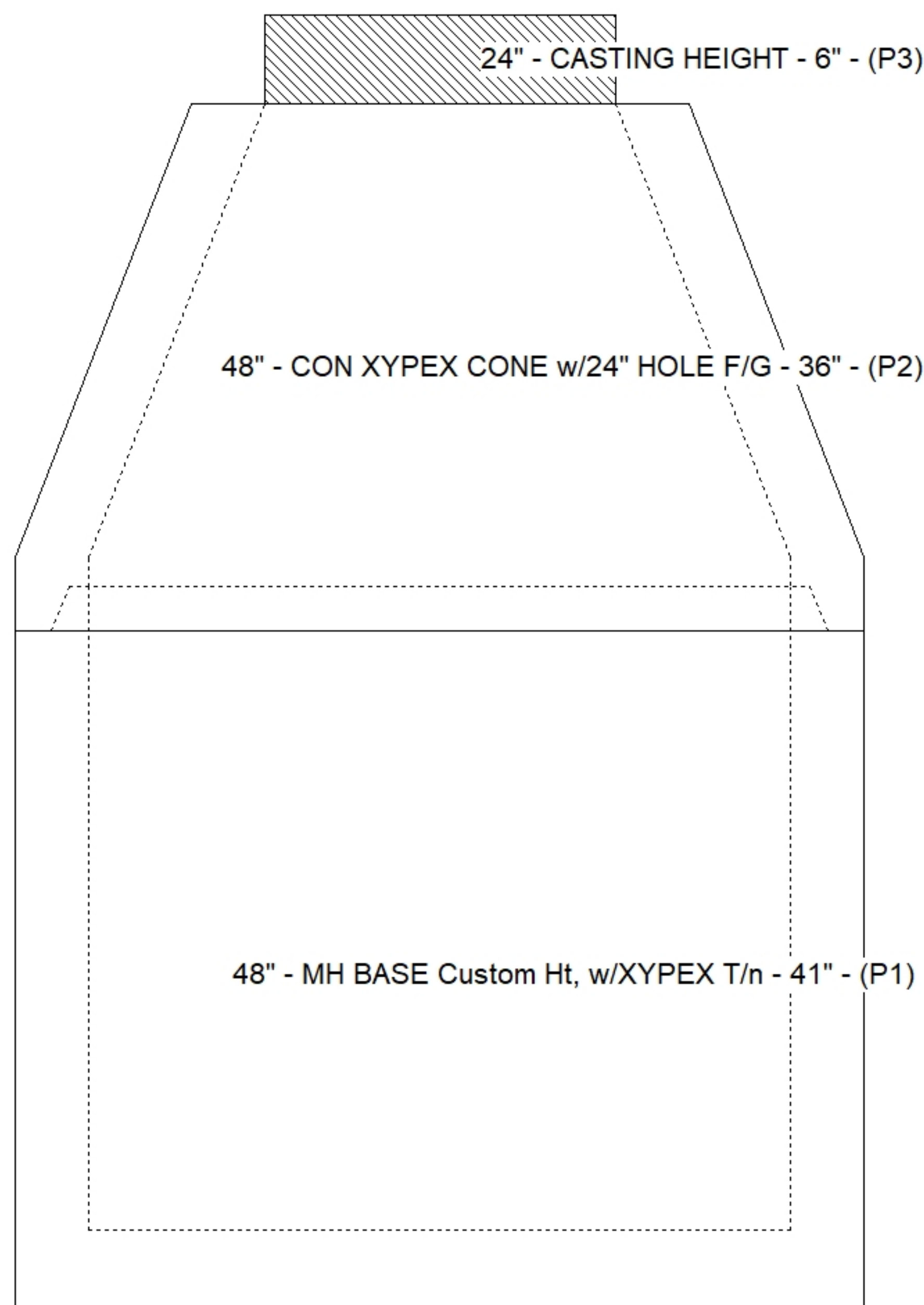

Cast (Int. Dim.) - Interior Dimensions

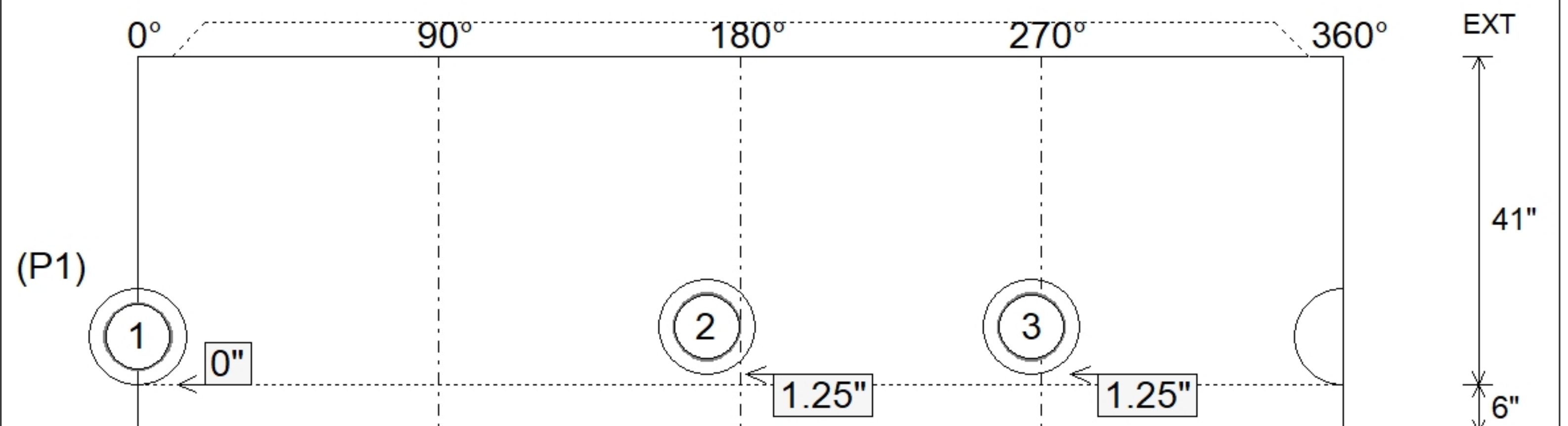

Submittal Drawing
 2/23/2026 4:38:33 PM

SUBMITTAL
 APPROVED BY: