

Job Name: 24-3511 Coles Ferry Section 18 & 19
 Job Location: Lebanon, TN
 Contractor: Covenant Constructors, LLC

Plant: Beaver Dam, KY
 2/23/2026 4:41:55 PM

Tech: J. Horsley
 PC: A. Chambers



Structure ID: JB1

P2 MH048LD12ECC

MH FLAT LID w/24in ECC Hole F/G

- P4) 24" - CASTING HEIGHT - 7"
- P3) 24" - GRADE RING F/F - 4"
- P2) 48" - MH FLAT LID w/24in ECC Hole F/G - 12"
- P1) 48" - MH BASE T/n - 36"
- 1) CASTING - JBS 1150 F/C STORM
- 1) 48" - Conseal CS-102 1.00"
- 2) Hole - 22
- 3) MH Step ML-10-TDS-NCR - 10"

0 lb
 270 lb
 1561 lb
 3516 lb
 250 lb
 0 lb
 0 lb
 0 lb

 Structure Total: 5597 lb

Structure Notes:

1. PER ASTM C478 SPECIFICATIONS.
2. CONCRETE = 4,500 PSI AT 28 DAYS.
3. NO INVERT CHANNEL.
4. CASTING BY ICAST (JBS 1150 F/C)

REINFORCING PER ASTM A615 (GRADE 60).
 - TOP SLAB H20 LOADING..
 - RISER/WALLS (As .12)
 - FLOOR (As .31) #5 BARS AT 12" C.C.E.W.

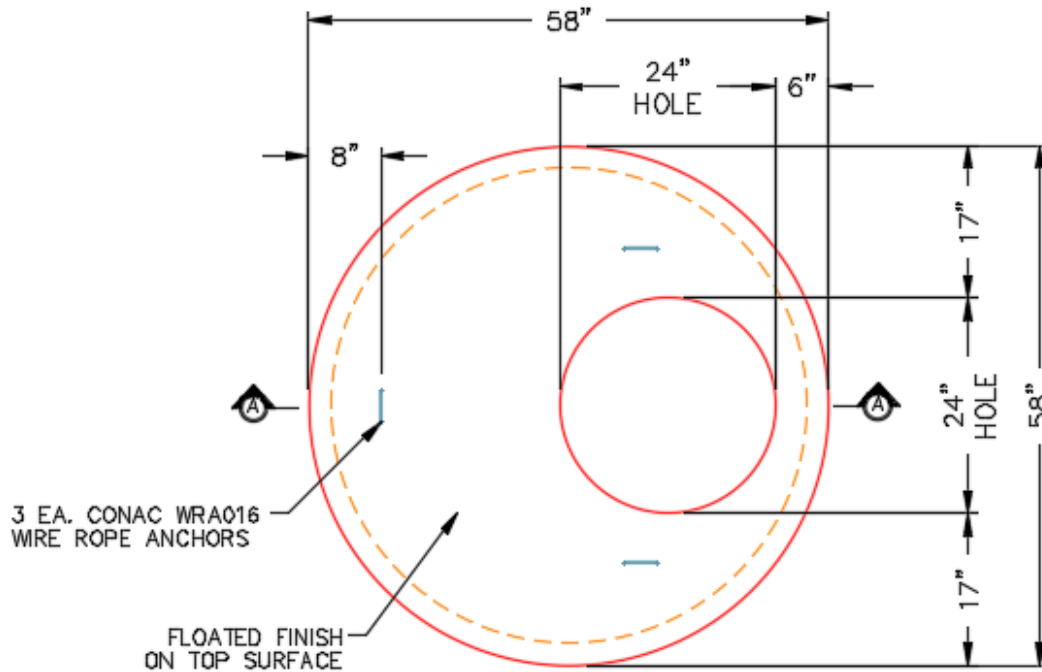

PLAN VIEW

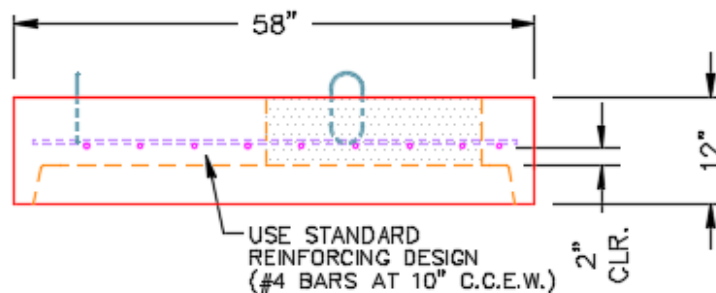

SECTION A-A

Coating (Int):
 Coating (Ext):

Seam Up: Flat
 Seam Dn: Groove

Wall Thickness: 5"

Height (Ext): 12"

Weight (Net): 1561 lb
 Volume (Net): 0.4cu.yd