

Job Name: 24-3462 Coles Ferry Section 20
 Job Location: Lebanon, TN
 Contractor: Covenant Constructors, LLC

Plant: Beaver Dam, KY
 2/23/2026 3:38:19 PM

Tech: J. Horsley
 PC: A. Chambers



Structure ID: SAMH C2

P1 MH048BAVFX

MH BASE Custom Ht, w/YYPEX T/n

- P3) 24" - CASTING HEIGHT - 6"
- P2) 48" - CON XYPEX CONE w/24" HOLE F/G - 36"
- P1) 48" - MH BASE Custom Ht, w/YYPEX T/n - 28"
- 1) 48" - MH INVERT CHANNEL w/YYPEX - FULL HEIGHT
- 1) JOINT WRAP - 0.065"x6"x50' CONSEAL CS212
- 1) JOINT WRAP PRIMER - CONSEAL CS-75 (1 gal.)
- 1) ADMIXTURE XYPEX C-1000 RED
- 1) CASTING - JBS 1155 F/C SANITARY
- 1) 48" - DBL 1"x14.5' Butyl (2x)
- 1) Kor-N-Seal1 - S106-12AW
- 1) Kor-N-Seal1 - S106-12BW
- 5) MH Step ML-10-TDS-NCR - 10"

Structure Notes:
 1. PER ASTM C478 SPECIFICATIONS.
 2. CONCRETE = 4,000 PSI AT 28 DAYS.
 3. ADMIXTURE = XYPEX C-1000 RED (AT 3.5% BY WEIGHT OF CONCRETE)
 4. CASTING BY ICAST (JBS 1155 F/C) SHIPPED LOOSE.

 REINFORCING PER ASTM A615 (GRADE 60).
 - CONE (As .12)
 - RISER (As .12)
 - FLOOR (As .31) #5 BARS AT 12" C.C.E.W.

0 lb
 2251 lb
 3190 lb
 1440 lb
 0 lb
 0 lb
 0 lb
 250 lb
 0 lb
 6 lb
 6 lb
 0 lb

 Structure Total: 7145 lb

Rim: 547.43' Rim to Invert: 5.73' Slack: 0.764" Sump: 2.004" Step Position: 250.5"

Position	Elev	Angle	Ext. (cw)	Pipe	Pipe OD	Connector	Hole	Horz Size	Up ()	Offset
Invert 1	541.7'	0°	0"	8" PVC SDR26	8.5"	Kor-N-Seal1 S106-12AW	12"	12.129"	0"	0"
Invert 2	541.9'	141°	71.375"	6" PVC SDR26	6.25"	Kor-N-Seal1 S106-12BW	12"	12.129"	1.375"	0"
Invert 3										
Invert 4										
Invert 5										
Invert 6										
Invert 7										
Invert 8										

RIGHT-SIDE UP VIEW (int. dimensions)

UPSIDE-DOWN VIEW (int. dimenions)

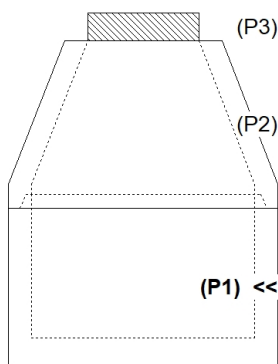
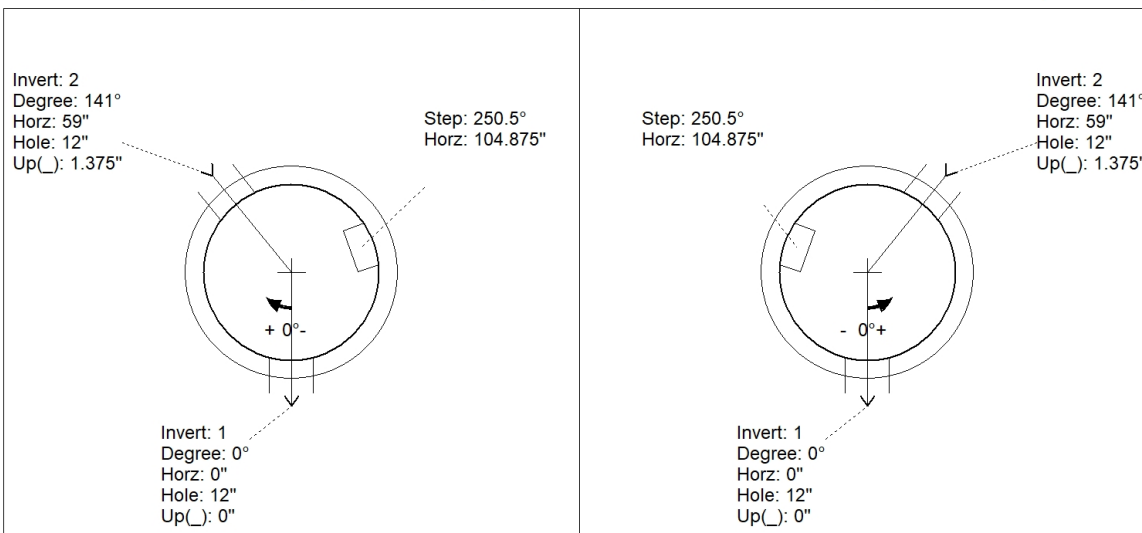

INSIDE WALL DIMENSIONS

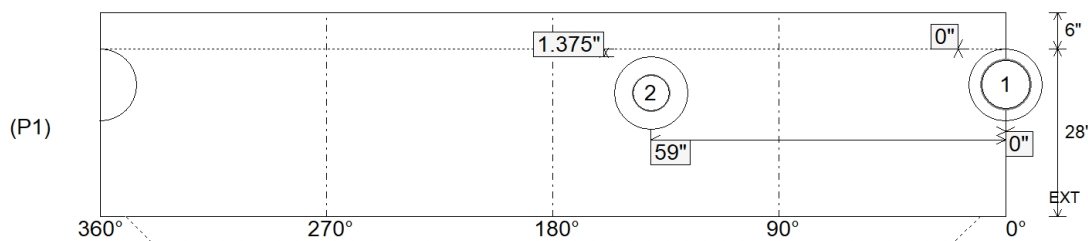

Coating (Int): Coating (Ext):	Seam Up: Tongue Seam Dn: n/a	Wall Thickness: 5" Floor Height: 6"	Height (Int): 28" Height (Ext): 34"	Weight (Net): 3190 lb Volume (Net): 0.82cu.yd
----------------------------------	---------------------------------	--	--	--

Job Name: 24-3462 Coles Ferry Section 20
 Job Location: Lebanon, TN
 Contractor: Covenant Constructors, LLC

Plant: Beaver Dam, KY
 2/23/2026 3:38:19 PM

Tech: J. Horsley
 PC: A. Chambers



Structure ID: SAMH C2

P1A MH048BAVFX

MH BASE Custom Ht, w/YYPEX T/n

- P3) 24" - CASTING HEIGHT - 6"
- P2) 48" - CON XYPEX CONE w/24" HOLE F/G - 36"
- P1) 48" - MH BASE Custom Ht, w/YYPEX T/n - 28"
- 1) 48" - MH INVERT CHANNEL w/YYPEX - FULL HEIGHT
- 1) JOINT WRAP - 0.065"x6"x50' CONSEAL CS212
- 1) JOINT WRAP PRIMER - CONSEAL CS-75 (1 gal.)
- 1) ADMIXTURE XYPEX C-1000 RED
- 1) CASTING - JBS 1155 F/C SANITARY
- 1) 48" - DBL 1"x14.5' Butyl (2x)
- 1) Kor-N-Seal1 - S106-12AW
- 1) Kor-N-Seal1 - S106-12BW
- 5) MH Step ML-10-TDS-NCR - 10"

0 lb
 2251 lb
 3190 lb
 1440 lb
 0 lb
 0 lb
 0 lb
 250 lb
 0 lb
 6 lb
 6 lb
 0 lb

Structure Total: 7145 lb

Structure Notes:

1. PER ASTM C478 SPECIFICATIONS.
2. CONCRETE = 4,000 PSI AT 28 DAYS.
3. ADMIXTURE = XYPEX C-1000 RED (AT 3.5% BY WEIGHT OF CONCRETE)
4. CASTING BY ICAST (JBS 1155 F/C) SHIPPED LOOSE.

REINFORCING PER ASTM A615 (GRADE 60).
 - CONE (As .12)
 - RISER (As .12)
 - FLOOR (As .31) #5 BARS AT 12" C.C.E.W.

Rim: 547.43' Rim to Invert: 5.73' Slack: 0.764" Sump: 2.004" Step Position: 250.5"

Position	Elev	Angle	Ext. (cw)	Pipe	Pipe OD	Connector	Hole	Horz Size	Up ()	Offset
Invert 1	541.7'	0°	0"	8" PVC SDR26	8.5"	Kor-N-Seal1 S106-12AW	12"	12.129"	0"	0"
Invert 2	541.9'	141°	71.375"	6" PVC SDR26	6.25"	Kor-N-Seal1 S106-12BW	12"	12.129"	1.375"	0"
Invert 3										
Invert 4										
Invert 5										
Invert 6										
Invert 7										
Invert 8										

RIGHT-SIDE UP VIEW (int. dimensions)

UPSIDE-DOWN VIEW (int. dimenions)

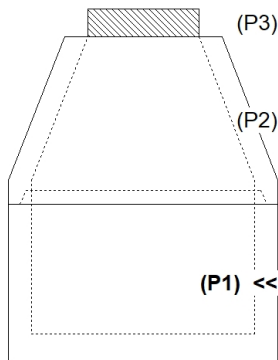
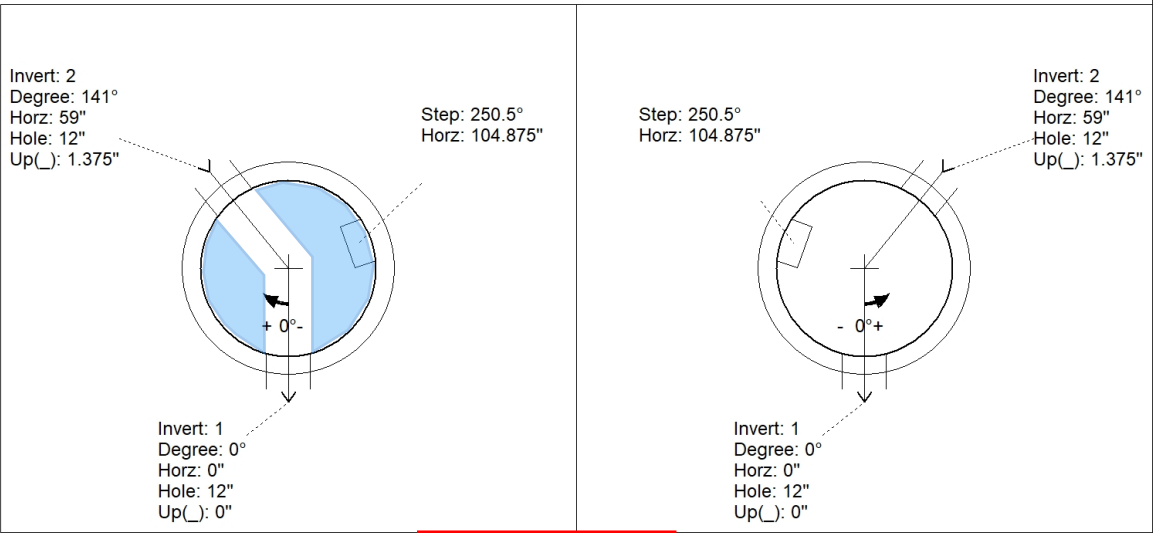

INSIDE WALL DIMENSIONS

FOR INVERT ONLY

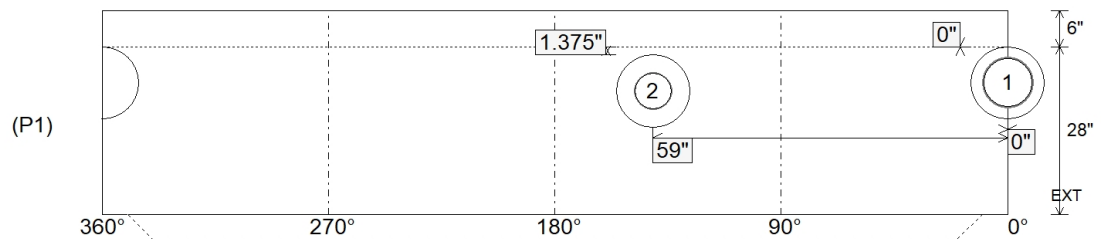

Coating (Int):
 Coating (Ext):

Seam Up: Tongue
 Seam Dn: n/a

Wall Thickness: 5"
 Floor Height: 6"

Height (Int): 28"
 Height (Ext): 34"

Weight (Net): 3190 lb
 Volume (Net): 0.82cu.yd