

Job Name: 24-3462 Coles Ferry Section 20
 Job Location: Lebanon, TN
 Contractor: Covenant Constructors, LLC

Plant: Beaver Dam, KY
 2/23/2026 3:38:51 PM

Tech: J. Horsley
 PC: A. Chambers



Structure ID: SAMH C1

P3 MH048CCN24X

CON XYPEX CONE w/24" HOLE F/G

P4) 24" - CASTING HEIGHT - 6"	0 lb
P3) 48" - CON XYPEX CONE w/24" HOLE F/G - 24"	2251 lb
P2) 48" - MH RISER w/XYPEX T/G - 24"	1677 lb
P1) 48" - MH BASE w/XYPEX T/n - 30"	3330 lb
1) 48" - MH INVERT CHANNEL w/XYPEX - FULL HEIGHT	1440 lb
1) JOINT WRAP - 0.065"x6"x50' CONSEAL CS212	0 lb
1) JOINT WRAP PRIMER - CONSEAL CS-75 (1 gal.)	0 lb
1) ADMIXTURE XYPEX C-1000 RED	0 lb
1) CASTING - JBS 1155 F/C SANITARY	250 lb
2) 48" - DBL 1"x14.5' Butyl (2x)	0 lb
1) Kor-N-Seal1 - S106-12AW	6 lb
1) Kor-N-Seal1 - S106-12BW	6 lb
6) MH Step ML-10-TDS-NCR - 10"	0 lb
Structure Total:	8961 lb

Structure Notes:
 1. PER ASTM C478 SPECIFICATIONS.
 2. CONCRETE = 4,000 PSI AT 28 DAYS.
 3. ADMIXTURE = XYPEX C-1000 RED (AT 3.5% BY WEIGHT OF CONCRETE)
 4. CASTING BY ICAST (JBS 1155 F/C) SHIPPED LOOSE.

 REINFORCING PER ASTM A615 (GRADE 60).
 - CONE (As .12)
 - RISER (As .12)
 - FLOOR (As .31) #5 BARS AT 12" C.C.E.W.

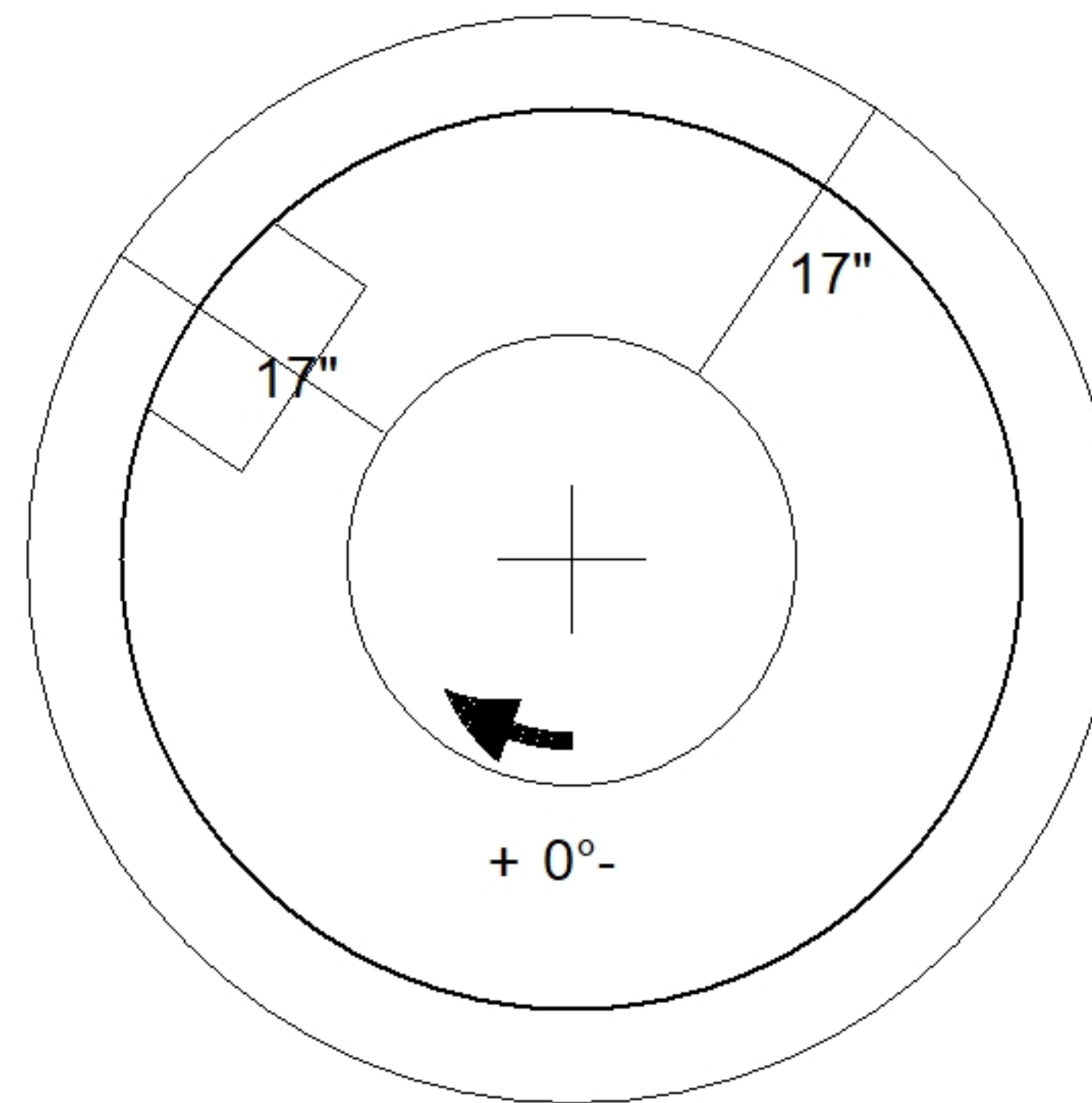

48" - CON XYPEX CONE w/24" HOLE F/G - 24" - (P3)

Coating (Int): Coating (Ext):	Seam Up: Flat Seam Dn: Groove	Wall Thickness: 5"	Height (Ext): 24"	Weight (Net): 2251 lb Volume (Net): 0.57cu.yd
----------------------------------	----------------------------------	--------------------	-------------------	--