

Structure ID: SAMH C1

P2 MH048RS24X

MH RISER w/XYPEX T/G

P4) 24" - CASTING HEIGHT - 6"	0 lb
P3) 48" - CON XYPEX CONE w/24" HOLE F/G - 24"	2251 lb
P2) 48" - MH RISER w/XYPEX T/G - 24"	1677 lb
P1) 48" - MH BASE w/XYPEX T/n - 30"	3330 lb
1) 48" - MH INVERT CHANNEL w/XYPEX - FULL HEIGHT	1440 lb
1) JOINT WRAP - 0.065"x6"x50' CONSEAL CS212	0 lb
1) JOINT WRAP PRIMER - CONSEAL CS-75 (1 gal.)	0 lb
1) ADMIXTURE XYPEX C-1000 RED	0 lb
1) CASTING - JBS 1155 F/C SANITARY	250 lb
2) 48" - DBL 1"x14.5' Butyl (2x)	0 lb
1) Kor-N-Seal1 - S106-12AW	6 lb
1) Kor-N-Seal1 - S106-12BW	6 lb
6) MH Step ML-10-TDS-NCR - 10"	0 lb
Structure Total:	8961 lb

Structure Notes:

1. PER ASTM C478 SPECIFICATIONS.
2. CONCRETE = 4,000 PSI AT 28 DAYS.
3. ADMIXTURE = XYPEX C-1000 RED (AT 3.5% BY WEIGHT OF CONCRETE)
4. CASTING BY ICAST (JBS 1155 F/C) SHIPPED LOOSE.

REINFORCING PER ASTM A615 (GRADE 60).

- CONE (As .12)
- RISER (As .12)
- FLOOR (As .31) #5 BARS AT 12" C.C.E.W.

Rim: 550.79' Rim to Invert: 6.86' Slack: 0.32" Sump: 2" Step Position: 124°

Position	Elev	Angle	Ext. (cw)	Pipe	Pipe OD	Connector	Hole	Horz Size	Up ()	Offset
Invert 1										
Invert 2										
Invert 3										
Invert 4										
Invert 5										
Invert 6										
Invert 7										
Invert 8										

RIGHT-SIDE UP VIEW (int. dimensions)

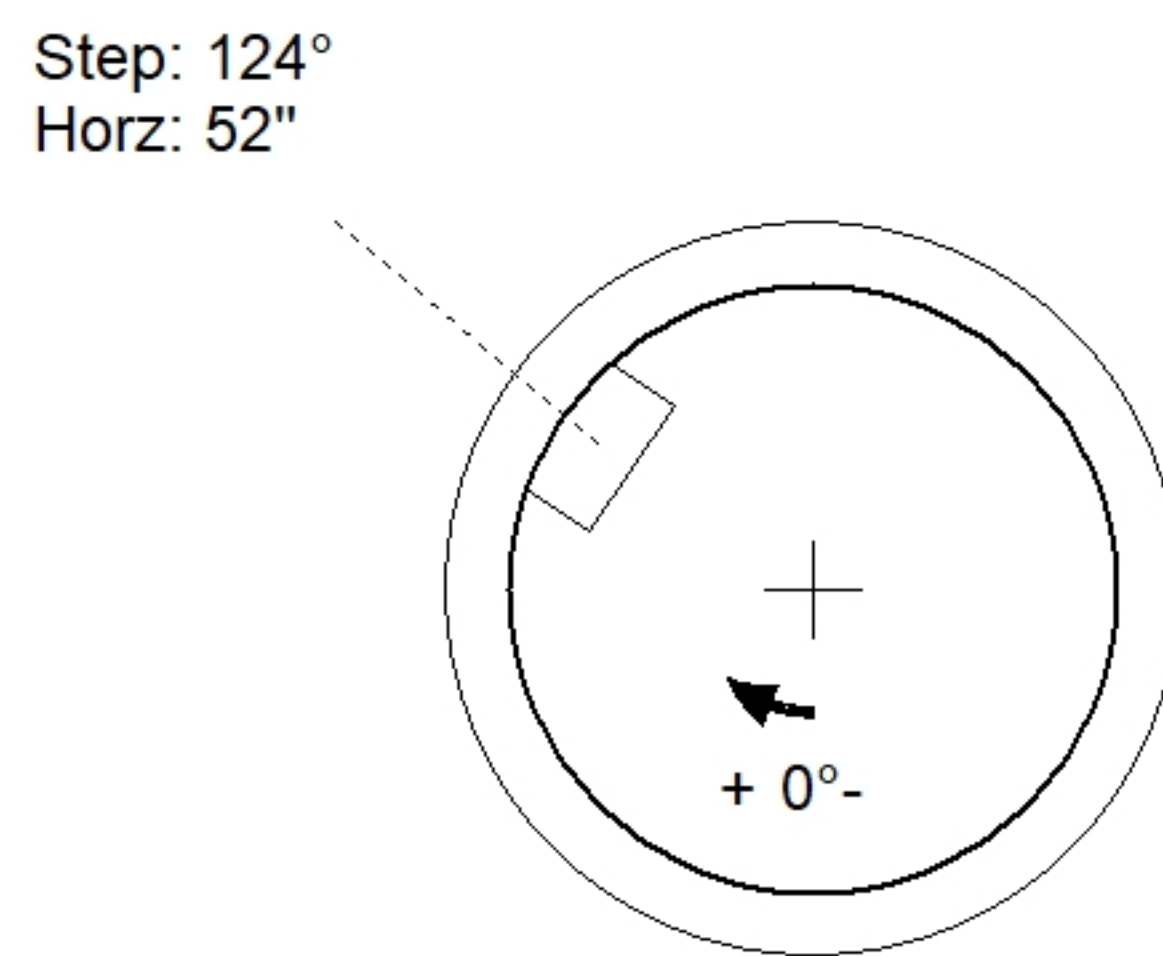
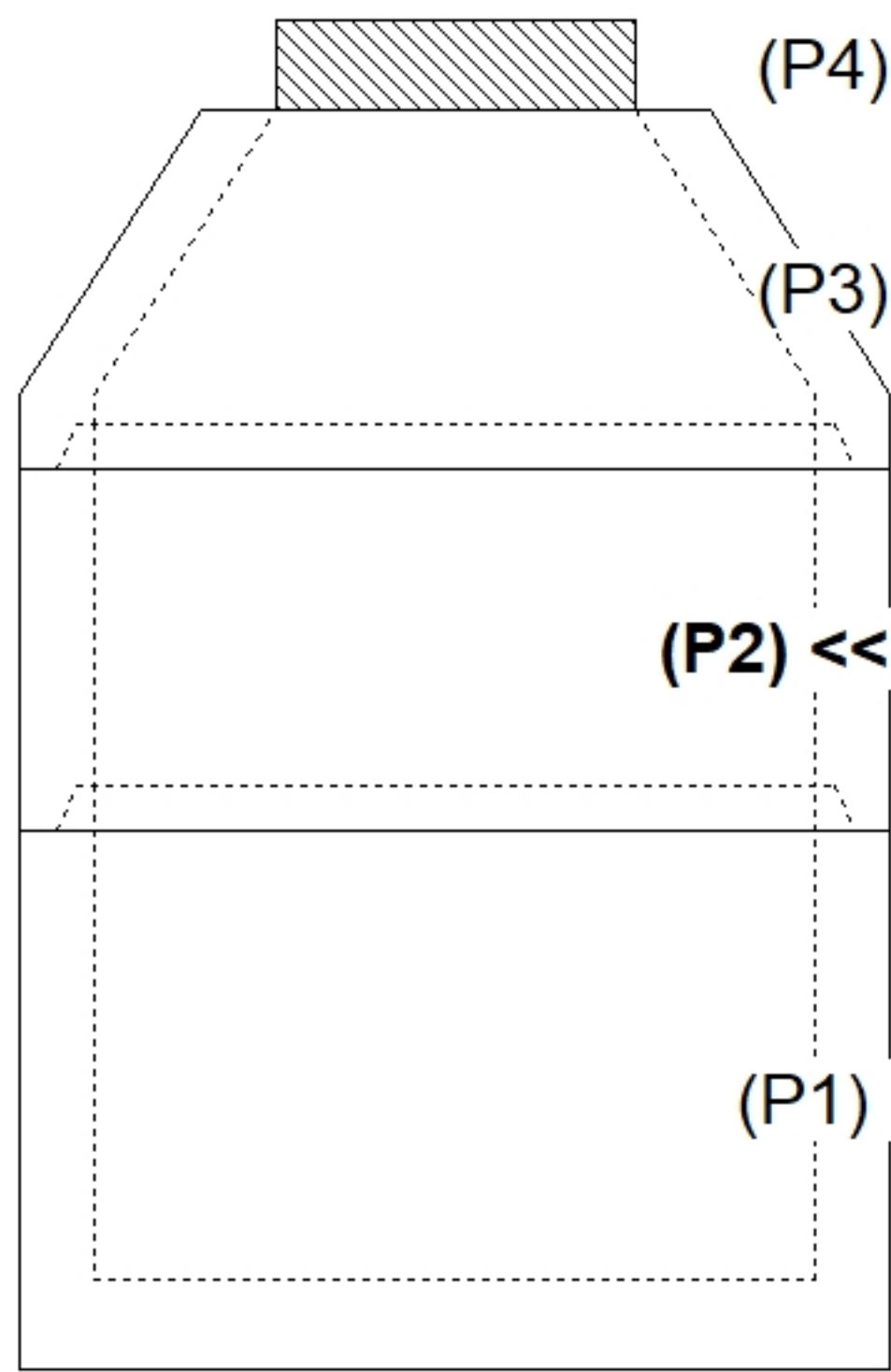

INSIDE WALL DIMENSIONS

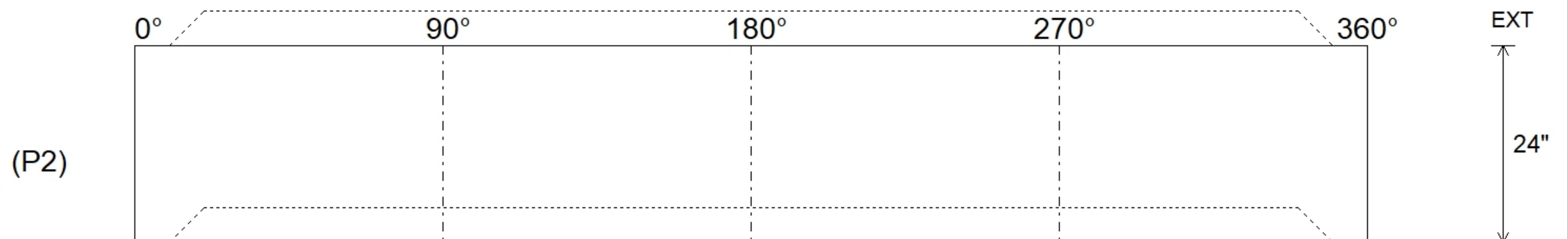

Coating (Int):	Seam Up: Tongue Seam Dn: Groove	Wall Thickness: 5" Floor Height: 0"	Height (Int): 24" Height (Ext): 24"	Weight (Net): 1677 lb Volume (Net): 0.43cu.yd
----------------	------------------------------------	--	--	--