

Job Name: 24-3462 Coles Ferry Section 20  
 Job Location: Lebanon, TN  
 Contractor: Covenant Constructors, LLC

Plant: Beaver Dam, KY  
 2/23/2026 3:38:17 PM

Tech: J. Horsley  
 PC: A. Chambers



**Structure ID: SAMH B1**

**P1 MH048BA36X**

**MH BASE w/XYPEX T/n**

- P3) 24" - CASTING HEIGHT - 6"
- P2) 48" - CON XYPEX CONE w/24" HOLE F/G - 24"
- P1) 48" - MH BASE w/XYPEX T/n - 36"
- 1) 48" - MH INVERT CHANNEL w/XYPEX - FULL HEIGHT
- 1) JOINT WRAP - 0.065"x6"x50' CONSEAL CS212
- 1) JOINT WRAP PRIMER - CONSEAL CS-75 (1 gal.)
- 1) ADMIXTURE XYPEX C-1000 RED
- 1) CASTING - JBS 1155 F/C SANITARY
- 1) 48" - DBL 1"x14.5' Butyl (2x)
- 1) Kor-N-Seal1 - S106-12AW
- 5) MH Step ML-10-TDS-NCR - 10"

0 lb  
 2251 lb  
 3797 lb  
 1440 lb  
 0 lb  
 0 lb  
 0 lb  
 250 lb  
 0 lb  
 6 lb  
 0 lb  
 -----  
 Structure Total: 7745 lb

**Structure Notes:**  
 1. PER ASTM C478 SPECIFICATIONS.  
 2. CONCRETE = 4,000 PSI AT 28 DAYS.  
 3. ADMIXTURE = XYPEX C-1000 RED (AT 3.5% BY WEIGHT OF CONCRETE)  
 4. CASTING BY ICAST (JBS 1155 F/C) SHIPPED LOOSE.  
  
 REINFORCING PER ASTM A615 (GRADE 60).  
 - CONE (As .12)  
 - RISER (As .12)  
 - FLOOR (As .31) #5 BARS AT 12" C.C.E.W.

Rim: 554.71' Rim to Invert: 5.36' Slack: 0.32' Sump: 2' Step Position: 180°

Position	Elev	Angle	Ext. (cw)	Pipe	Pipe OD	Connector	Hole	Horz Size	Up ( )	Offset
Invert 1	549.35'	0°	0"	8" PVC SDR26	8.5"	Kor-N-Seal1 S106-12AW	12"	12.129"	0"	0"
Invert 2										
Invert 3										
Invert 4										
Invert 5										
Invert 6										
Invert 7										
Invert 8										

RIGHT-SIDE UP VIEW (int. dimensions)

UPSIDE-DOWN VIEW (int. dimensions)

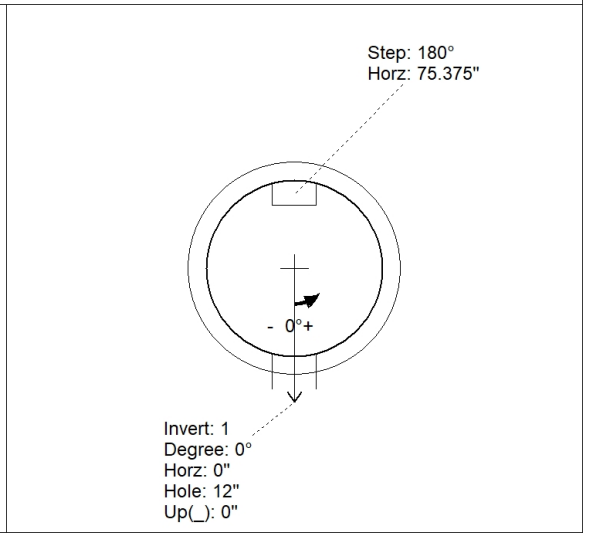
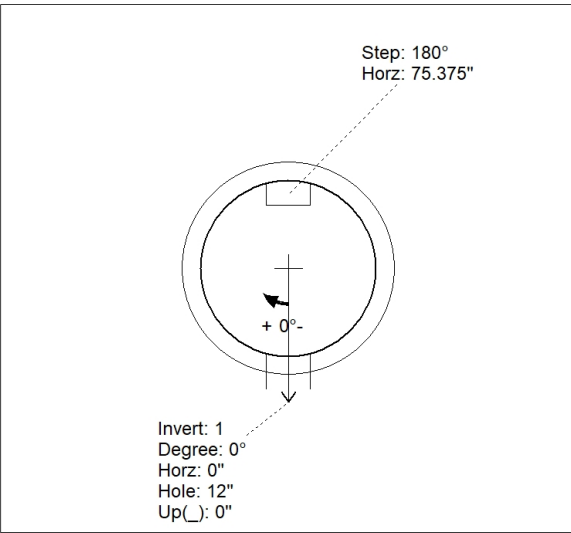
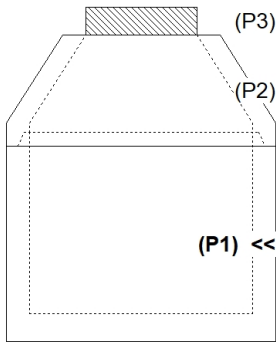

INSIDE WALL DIMENSIONS

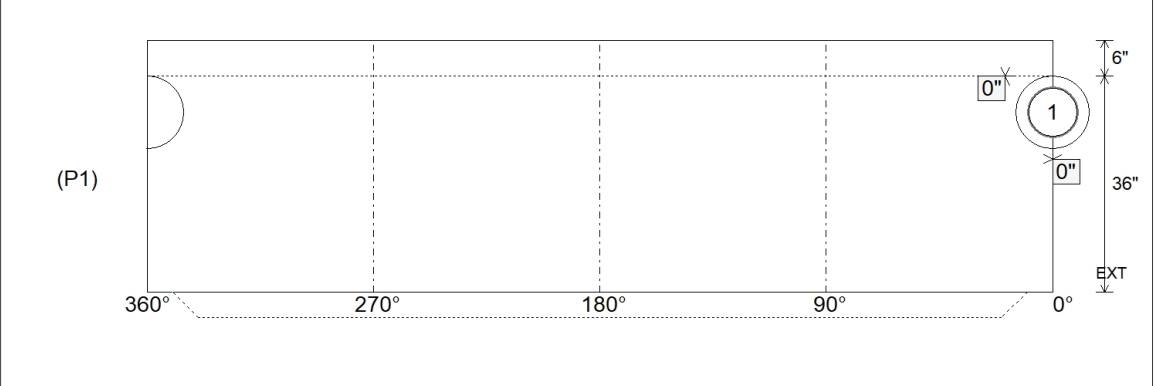

Coating (Int): Coating (Ext):	Seam Up: Tongue Seam Dn: n/a	Wall Thickness: 5" Floor Height: 6"	Height (Int): 36" Height (Ext): 42"	Weight (Net): 3797 lb Volume (Net): 0.97cu.yd
----------------------------------	---------------------------------	--	--	--

Job Name: 24-3462 Coles Ferry Section 20  
 Job Location: Lebanon, TN  
 Contractor: Covenant Constructors, LLC

Plant: Beaver Dam, KY  
 2/23/2026 3:38:17 PM

Tech: J. Horsley  
 PC: A. Chambers



**Structure ID: SAMH B1**

**P1A MH048BA36X**

**MH BASE w/XYPEX T/n**

- P3) 24" - CASTING HEIGHT - 6"
- P2) 48" - CON XYPEX CONE w/24" HOLE F/G - 24"
- P1) 48" - MH BASE w/XYPEX T/n - 36"
- 1) 48" - MH INVERT CHANNEL w/XYPEX - FULL HEIGHT
- 1) JOINT WRAP - 0.065"x6"x50' CONSEAL CS212
- 1) JOINT WRAP PRIMER - CONSEAL CS-75 (1 gal.)
- 1) ADMIXTURE XYPEX C-1000 RED
- 1) CASTING - JBS 1155 F/C SANITARY
- 1) 48" - DBL 1"x14.5' Butyl (2x)
- 1) Kor-N-Seal1 - S106-12AW
- 5) MH Step ML-10-TDS-NCR - 10"

0 lb  
 2251 lb  
 3797 lb  
 1440 lb  
 0 lb  
 0 lb  
 0 lb  
 250 lb  
 0 lb  
 6 lb  
 0 lb  
 -----  
 Structure Total: 7745 lb

**Structure Notes:**  
 1. PER ASTM C478 SPECIFICATIONS.  
 2. CONCRETE = 4,000 PSI AT 28 DAYS.  
 3. ADMIXTURE = XYPEX C-1000 RED (AT 3.5% BY WEIGHT OF CONCRETE)  
 4. CASTING BY ICAST (JBS 1155 F/C) SHIPPED LOOSE.  
  
 REINFORCING PER ASTM A615 (GRADE 60).  
 - CONE (As .12)  
 - RISER (As .12)  
 - FLOOR (As .31) #5 BARS AT 12" C.C.E.W.

Rim: 554.71' Rim to Invert: 5.36' Slack: 0.32' Sump: 2' Step Position: 180°

Position	Elev	Angle	Ext. (cw)	Pipe	Pipe OD	Connector	Hole	Horz Size	Up ( )	Offset
Invert 1	549.35'	0°	0"	8" PVC SDR26	8.5"	Kor-N-Seal1 S106-12AW	12"	12.129"	0"	0"
Invert 2										
Invert 3										
Invert 4										
Invert 5										
Invert 6										
Invert 7										
Invert 8										

RIGHT-SIDE UP VIEW (int. dimensions)

UPSIDE-DOWN VIEW (int. dimensions)

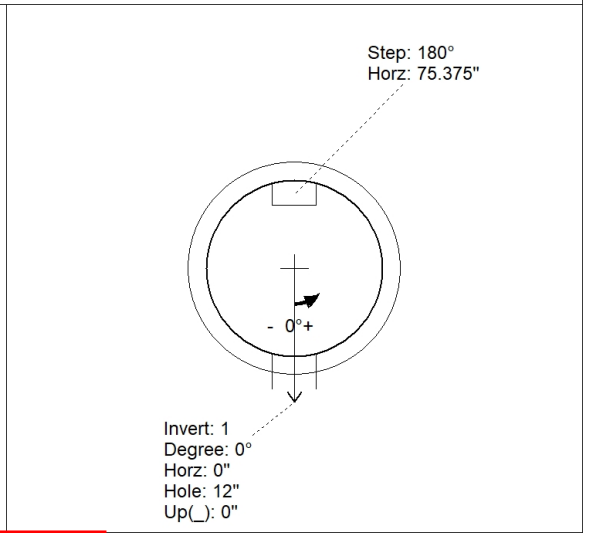
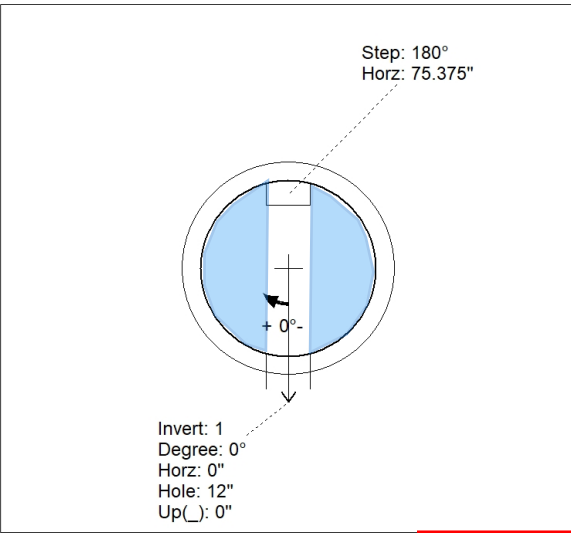
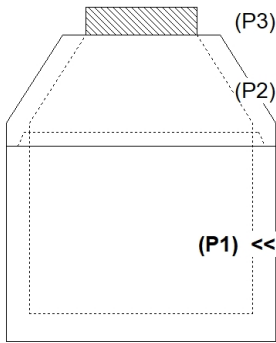

INSIDE WALL DIMENSIONS

**FOR INVERT ONLY**

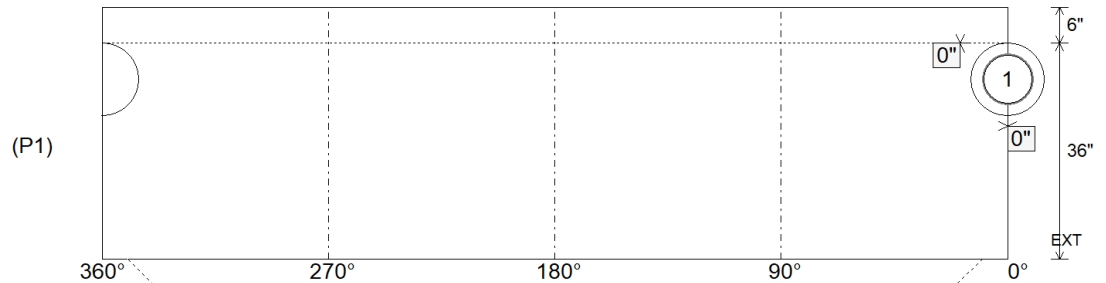

Coating (Int):  
 Coating (Ext):

Seam Up: Tongue  
 Seam Dn: n/a

Wall Thickness: 5"  
 Floor Height: 6"

Height (Int): 36"  
 Height (Ext): 42"

Weight (Net): 3797 lb  
 Volume (Net): 0.97cu.yd