

Structure ID: SAMH A2

P2 MH048RS36X

MH RISER w/XYPEX T/G

P4) 24" - CASTING HEIGHT - 6" P3) 48" - CON XYPEX CONE w/24" HOLE F/G - 24" P2) 48" - MH RISER w/XYPEX T/G - 36" P1) 48" - MH BASE Custom Ht, w/XYPEX T/n - 28" 1) 48" - MH INVERT CHANNEL w/XYPEX - FULL HEIGHT 1) JOINT WRAP - 0.065"x6"x50' CONSEAL CS212 1) JOINT WRAP PRIMER - CONSEAL CS-75 (1 gal.) 1) ADMIXTURE XYPEX C-1000 RED 1) CASTING - JBS 1155 F/C SANITARY 2) 48" - DBL 1"x14.5' Butyl (2x) 2) Kor-N-Seal1 - S106-12AW 7) MH Step ML-10-TDS-NCR - 10"	0 lb 2251 lb 2515 lb 3190 lb 1440 lb 0 lb 0 lb 0 lb 250 lb 0 lb 13 lb 0 lb ----- Structure Total: 9659 lb
---	--

Structure Notes:

1. PER ASTM C478 SPECIFICATIONS.
2. CONCRETE = 4,000 PSI AT 28 DAYS.
3. ADMIXTURE = XYPEX C-1000 RED (AT 3.5% BY WEIGHT OF CONCRETE)
4. CASTING BY ICAST (JBS 1155 F/C) SHIPPED LOOSE.

REINFORCING PER ASTM A615 (GRADE 60).

- CONE (As .12)
- RISER (As .12)
- FLOOR (As .31) #5 BARS AT 12" C.C.E.W.

Rim: 561.43' Rim to Invert: 7.68' Slack: 0.16" Sump: 2" Step Position: 254.5°

Position	Elev	Angle	Ext. (cw)	Pipe	Pipe OD	Connector	Hole	Horz Size	Up (L)	Offset
Invert 1										
Invert 2										
Invert 3										
Invert 4										
Invert 5										
Invert 6										
Invert 7										
Invert 8										

RIGHT-SIDE UP VIEW (int. dimensions)

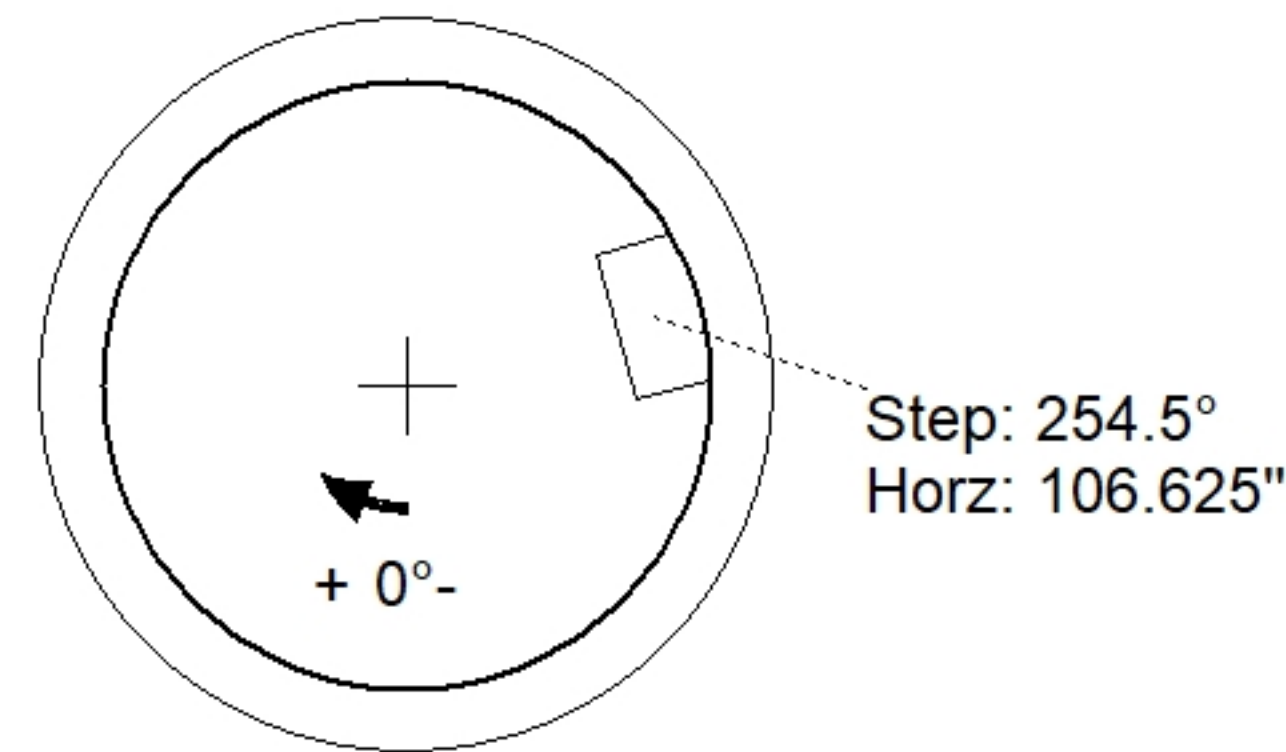
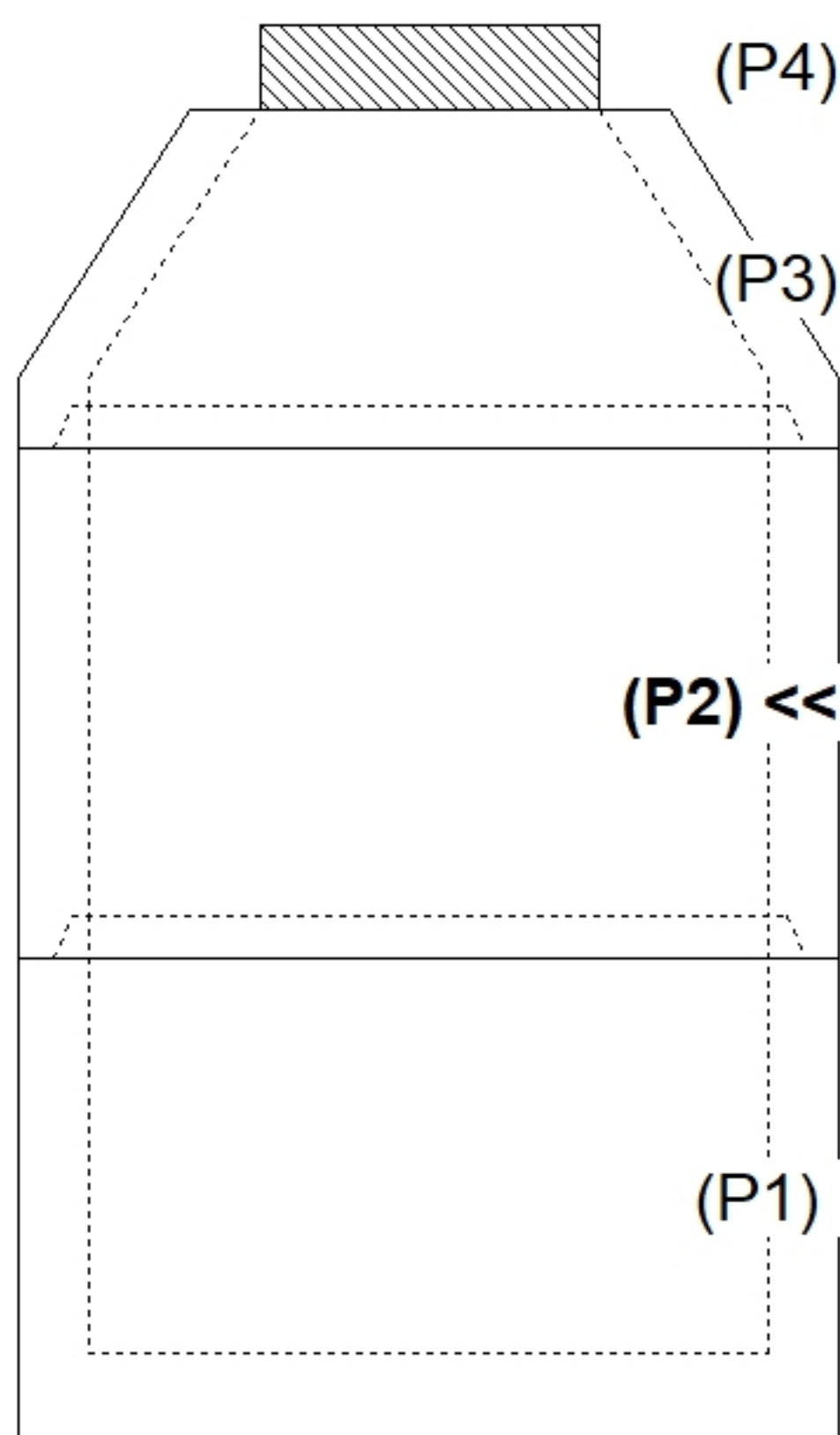

INSIDE WALL DIMENSIONS

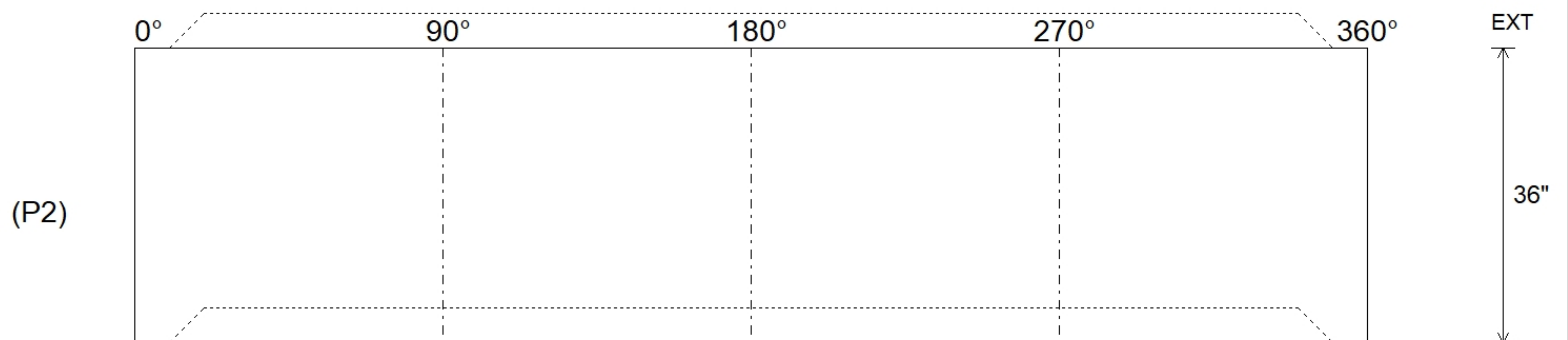

Coating (Int):	Seam Up: Tongue Seam Dn: Groove	Wall Thickness: 5" Floor Height: 0"	Height (Int): 36" Height (Ext): 36"
Coating (Ext):			Weight (Net): 2515 lb Volume (Net): 0.64cu.yd