

Structure ID: CB-054A (SGL AD) D-CB-42RB

P1 MH060BA66 MH BASE T/n

P4) 32" x 32" - RECESS/GRATE SEAT - 2" P3) 60" - MH FLAT TOP - TDOT NO 42 (32"x32" Hole) F/F - 14" P2) 60" - MH RISER F/G - 12" P1) 60" - MH BASE T/n - 66" 2) 60" - SGL 1"x14.5' Butyl (2x) 2) Hole - 46	0 lb 3629 lb 1253 lb 7762 lb 0 lb 0 lb ----- Structure Total: 12644 lb
--	---

Structure Notes:

1. PER TDOT D-CB-42RB / ASTM C478 SPEC'S.
2. CONCRETE = 4,000 PSI AT 28 DAYS.
3. NO INVERT CHANNEL.
4. CASTING BY OTHERS (TNDOT TYPE 42RB - JBS 4200 GRATE).
5. 2" WD x 2" DEEP GRATE SEAT/RECESS IN STEPPED TOP SLAB.

REINFORCING PER ASTM A615 (GRADE 60).
 ** PER TDOT STD DRAWING D-CB-42RB **

- TOP SLAB - DBL MAT #5 BARS.
- RISER (As .18)
- FLOOR (As .62) #5 BARS AT 6" C.C.E.W.

Rim: 641.5' Rim to Invert: 7.64' Slack: 3.68" Sump: 4" Step Position:

Position	Elev	Angle	Ext. (cw)	Pipe	Pipe OD	Connector	Hole	Horz Size	Up ()	Offset
Invert 1	633.86'	0°	0"	36" RCP B WALL	44"	Hole 46	46"	52.418"	0"	0"
Invert 2	634.03'	205°	128.75"	36" RCP B WALL	44"	Hole 46	46"	52.418"	2"	0"
Invert 3										
Invert 4										
Invert 5										
Invert 6										
Invert 7										
Invert 8										

RIGHT-SIDE UP VIEW (int. dimensions)

UPSIDE-DOWN VIEW (int. dimensions)

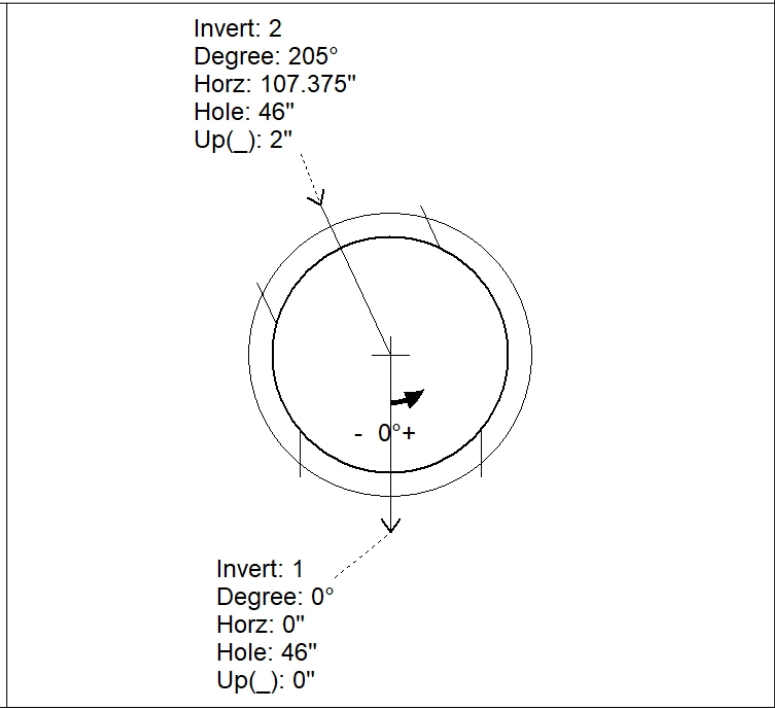
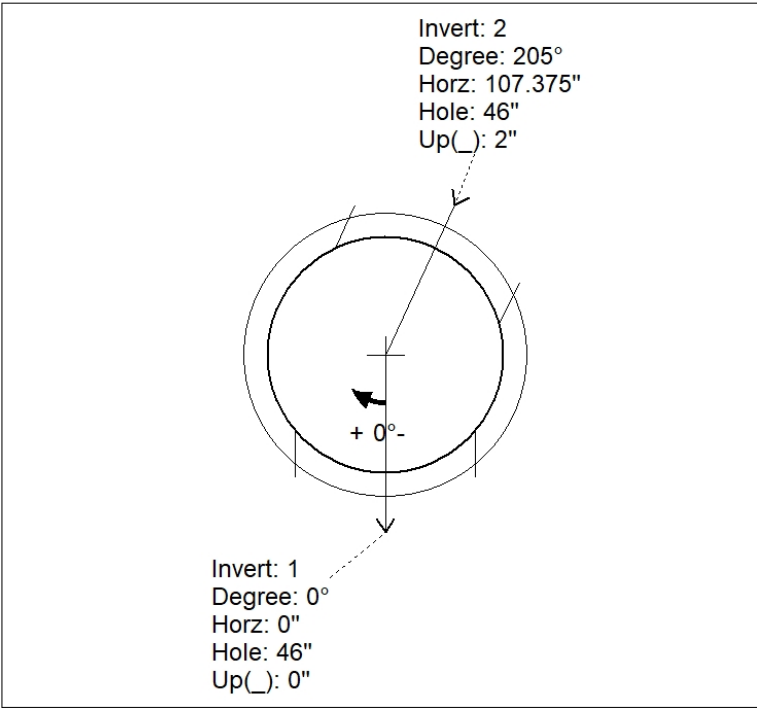
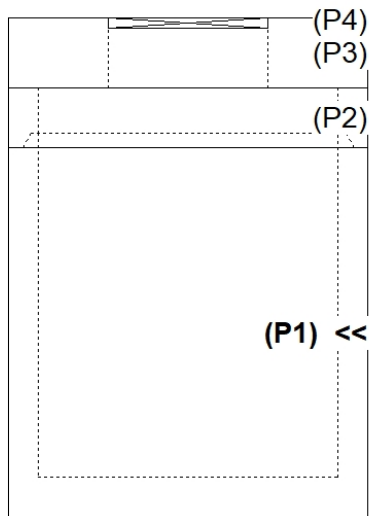

INSIDE WALL DIMENSIONS

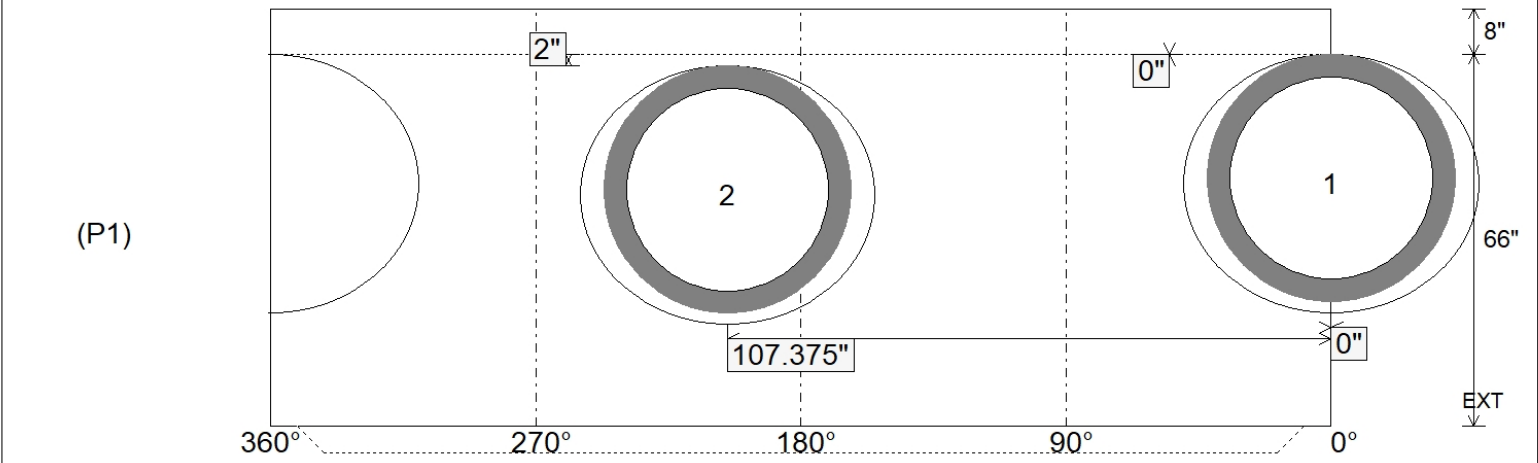

Coating (Int): Coating (Ext):	Seam Up: Tongue Seam Dn: n/a	Wall Thickness: 6" Floor Height: 8"	Height (Int): 66" Height (Ext): 74"	Weight (Net): 7762 lb Volume (Net): 1.98cu.yd
----------------------------------	---------------------------------	--	--	--