

**Structure ID: B4**

**P1 MH048BAVF**

**MH BASE Custom Ht F/n**

P3) 24" - CASTING HEIGHT - 0" P2) 48" - MH FLAT TOP SPEC. HT. (6") F/F - 6" P1) 48" - MH BASE Custom Ht F/n - 44" 1) 48" - Conseal CS-102 1.00" 1) Hole - 26 4) Horiz Slot n/n - 30"x6"	0 lb 1102 lb 3849 lb 0 lb 0 lb 0 lb ----- 4951 lb	<b>Structure Notes:</b> 1. PER ASTM C-478 SPECS 2. CONCRETE: 4,000 PSI AT 28 DAYS 3. REINFORCEMENT: PER ASMT A615 4. NO STEPS 5. CASTING: JBS 2072 SUPPLIED BY OTHERS 6. CASTING FRAME TO BE CAST INTO FLAT LID FLANGE SIDE UP
--	--	--

Structure Total: 4951 lb

Rim: 555.52'    Rim to Invert: 3.96'    Slack: 0.02"    Sump: 2.5"    Step Position:

Position	Elev	Angle	Ext. (cw)	Pipe	Pipe OD	Connector	Hole	Horz Size	Up ( )	Offset
Invert 1	551.56'	0°	0"	18" RCP B WALL	23"	Hole 26	26"	27.476"	0"	0"
Invert 2	554.518'	0°	0"	30" x 6" Horiz Slot	30" x 6"	Horiz Slot 30"x6"	30" x 6"	32.406"	38"	0"
Invert 3	554.518'	90°	45.553"	30" x 6" Horiz Slot	30" x 6"	Horiz Slot 30"x6"	30" x 6"	32.406"	38"	0"
Invert 4	554.518'	180°	91.106"	30" x 6" Horiz Slot	30" x 6"	Horiz Slot 30"x6"	30" x 6"	32.406"	38"	0"
Invert 5	554.518'	270°	136.659"	30" x 6" Horiz Slot	30" x 6"	Horiz Slot 30"x6"	30" x 6"	32.406"	38"	0"
Invert 6										
Invert 7										
Invert 8										

RIGHT-SIDE UP VIEW (int. dimensions)

UPSIDE-DOWN VIEW (int. dimensions)

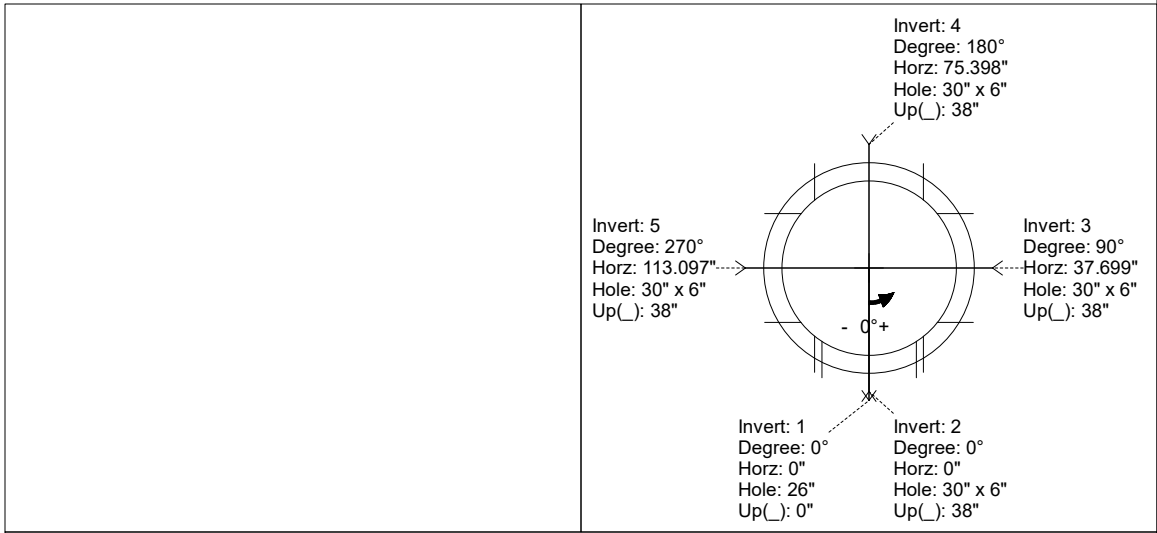
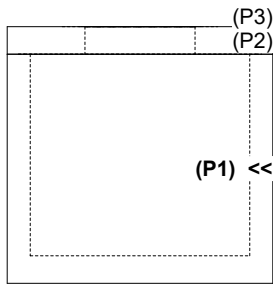

INSIDE WALL DIMENSIONS

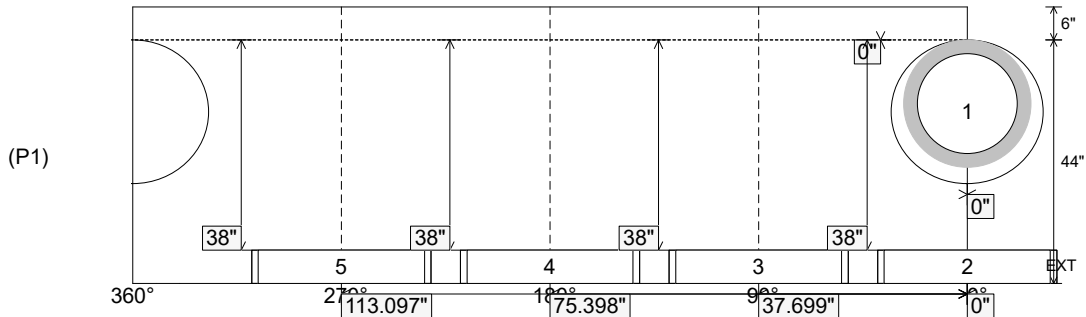

Coating (Int): Coating (Ext):	Seam Up: Flat Seam Dn: n/a	Wall Thickness: 5" Floor Height: 6"	Height (Int): 44" Height (Ext): 50"	Weight (Net): 3849 lb Volume (Net): 0.98cu.yd
----------------------------------	-------------------------------	--	--	--