

Job Name: 24-2716 905 E Trinity
 Job Location: Nashville, TN
 Contractor: Hayes Pipe Supply

Plant: Beaver Dam, KY
 10/15/2025 11:18:54 AM

Tech: K. Cardwell
 PC: A. Chambers



Structure ID: A1 (San)

P3 MH048CCN24CDARED

CON CONE w/24" HOLE, w/ConBlock-CDA Red F/G

P4) 24" - CASTING HEIGHT - 7"	0 lb
P3) 48" - CON CONE w/24" HOLE, w/ConBlock-CDA Red F/G - 24"	1297 lb
P2) 48" - MH RISER w/DROP/ConBlock-CDA Red T/G - 66"	7435 lb
P1) 48" - MH BASE w/DROP/ConBlock-CDA Red T/n - 24"	4187 lb
1) JOINT WRAP PRIMER - CONSEAL CS-75 (1 gal.)	0 lb
1) ADMIXTURE CONBLOCK CDA RED	0 lb
1) 48" - MH INVERT CHANNEL w/ConBlock-CDA Red - FULL HEIGHT	1440 lb
1) JOINT WRAP - 0.065"x6"x50' CONSEAL CS212	0 lb
2) 48" - Conseal CS-102 1.00" (Double)	0 lb
1) PSX - 12M NYLO	8 lb
1) Drop Tee - 6" PVC	0 lb
1) PSX - 12-08 NYLO	8 lb
1) Drop Elbow - 6" PVC	0 lb
10) MH Step ML-10-TDS-NCR - 10"	0 lb
Structure Total:	14375 lb

Structure Notes:
 1. PER ASTM C-478 SPECS
 2. CONCRETE: 4,000 PSI AT 28 DAYS
 3. REINFORCEMENT: PER ASTM A615
 4. CONBLOCK CDA RED ADMIXTURE REQUIRED
 5. INVERT CHANNEL REQUIRED
 6. STEPS AT 195 DEGREES
 7. CASTING: JBS 1150 "SANITARY" SUPPLIED BY OTHERS

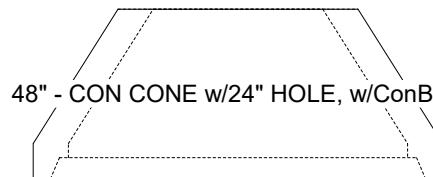
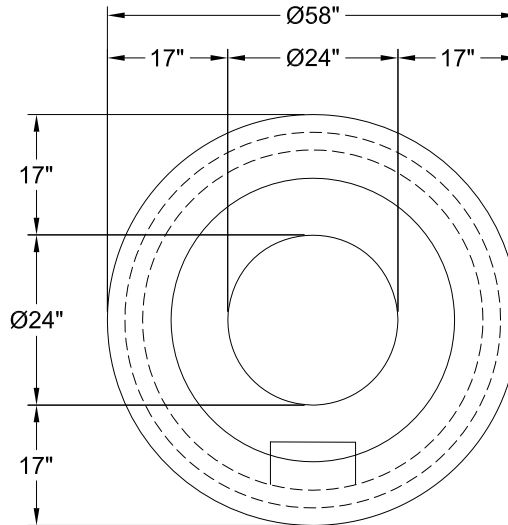

48" - CON CONE w/24" HOLE, w/ConBlock-CDA Red F/G - 24" - (P3)

Coating (Int): Coating (Ext):	Seam Up: Flat Seam Dn: Groove	Wall Thickness: 5"	Height (Ext): 24"	Weight (Net): 1297 lb Volume (Net): 0.33cu.yd
----------------------------------	----------------------------------	--------------------	-------------------	--