

TOP VIEW

NOTES:

1. MANUFACTURED PER ASTM C913 SPECIFICATIONS.
2. CONCRETE: 4,000 PSI AT 28 DAYS.
3. JOINT SEALANT: 1" BUTYL CS-102.
4. REINFORCING PER ASTM A615 (GRADE 60). WALLS (As .47) #5 BARS AT 8" C/C E.W.
5. WEIGHT:
RISER.....12,669 LBS.

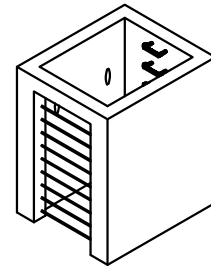

ISOMETRIC VIEW

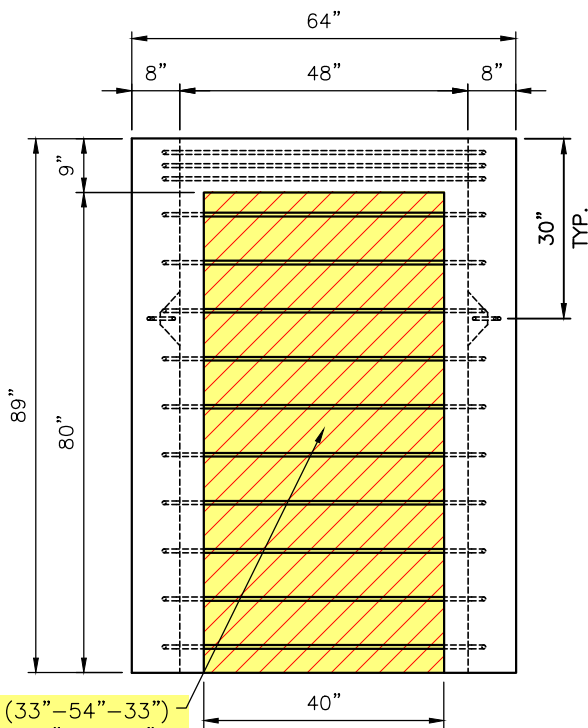

FRONT VIEW

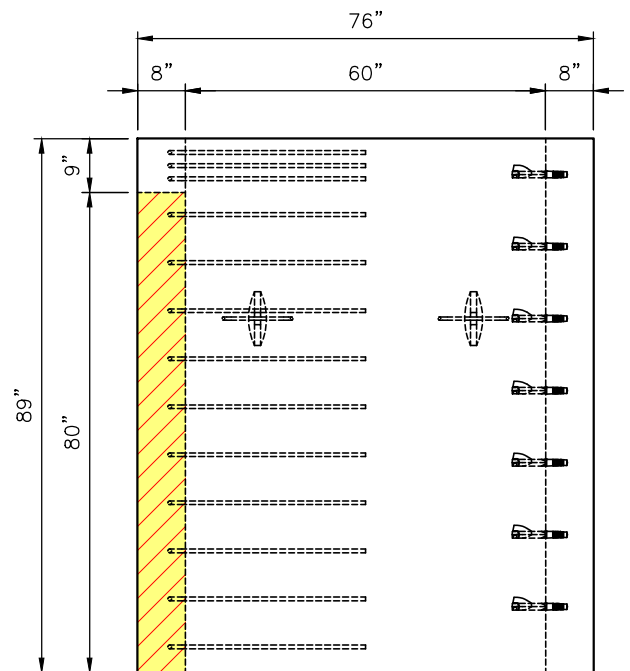

SIDE VIEW

#5 U-BARS (33"-54"-33") @ 8" C/C & 40"W x 80"H STYROFOAM BLOCKING TO REMAIN IN PLACE UNTIL STRUCTURE IS SET IN THE FIELD

GVV 05 - 83+58 E. KENTUCKY ST.

PRODUCTION WORK ORDER		PRODUCT I.D.: CVR	DESCRIPTION: RISER 48"x60"x89"H (8W/8F) F/F		
	QUALITY CONTROL CHECKLIST	PRODUCT VIEW: RIGHT SIDE UP	CUSTOMER: GARNEY COMPANIES, INC.		
	<input type="checkbox"/> ALL DIMENSIONS CORRECT.	PLANT: BEAVER DAM, KY.	PROJECT: KY OAK GLENMARY 48" MAIN REHAB PH.2		
	<input type="checkbox"/> LIFTERS INSTALLED.	WEIGHT: 12,669 LBS.	STRUCTURE: GVV 05 P1		
	<input type="checkbox"/> OPENING CENTERED.	TOP SECTION JOINT: FLAT	ORDER NO: 24-2570		
	<input type="checkbox"/> REINFORCING CORRECT.	BASE SECTION JOINT: FLAT	PC: A. CHAMBERS	DRAWING: M. BILITER	
	<input type="checkbox"/> SURFACE QUALITY ACCEPTABLE.	QC CHECK INITIALS:	DATE: 02/28/25	SCALE: NTS	PG. 1 of 1
<input type="checkbox"/> EDGES CHAMFERED.					
<input type="checkbox"/> ALL PATCHWORK ACCEPTABLE.					