

**Structure ID: A4**

**P1 MH048BAVF**

**MH BASE Custom Ht T/n**

P3) 28" x 28" - CASTING HEIGHT - 7.50" P2) 48" - MH FLAT TOP w/28"x28" Hole F/G - 12" P1) 48" - MH BASE Custom Ht T/n - 67" 1) 48" - Conseal CS-102 1.00" 1) 28" x 28" - Conseal CS-102 1.00" 2) Hole - 34 1) Hole - 22 5) MH Step ML-10-TDS-NCR - 10"	0 lb 1368 lb 5016 lb 0 lb 0 lb 0 lb 0 lb 0 lb 0 lb 0 lb ----- 6384 lb	Structure Total: 6384 lb
---	--	--------------------------

**Structure Notes:**  
 PLAN LABEL: A4  
 1. JBS-3300 PROVIDED BY OTHERS.  
 2. PER ASTM C478 SPECIFICATIONS.  
 3. CONCRETE = 4,000 PSI AT 28 DAYS.  
 4. REINFORCING PER ASTM A615 (GRADE 60).  
 - TOP SLAB (As .62) #5 BARS AT 6" C.C.E.W..  
 - RISER/WALLS (As .12)  
 - FLOOR (As .31) #5 BARS AT 12" C.C.E.W.

Rim: 432'      Rim to Invert: 7'      Slack: 0.5"      Sump: 3"      Step Position: 0°

Position	Elev	Angle	Ext. (cw)	Pipe	Pipe OD	Connector	Hole	Horz Size	Up ( )	Offset
Invert 1	425'	0°	0"	24" RCP B WALL	30"	Hole 34	34"	37.782"	0"	0"
Invert 2	428'	90°	45.5"	15" RCP B WALL	19.5"	Hole 22	22"	22.854"	36.75"	0"
Invert 3	425.2'	180°	91.125"	24" RCP B WALL	30"	Hole 34	34"	37.782"	2.375"	0"
Invert 4										
Invert 5										
Invert 6										
Invert 7										
Invert 8										

RIGHT-SIDE UP VIEW (int. dimensions)

UPSIDE-DOWN VIEW (int. dimensions)

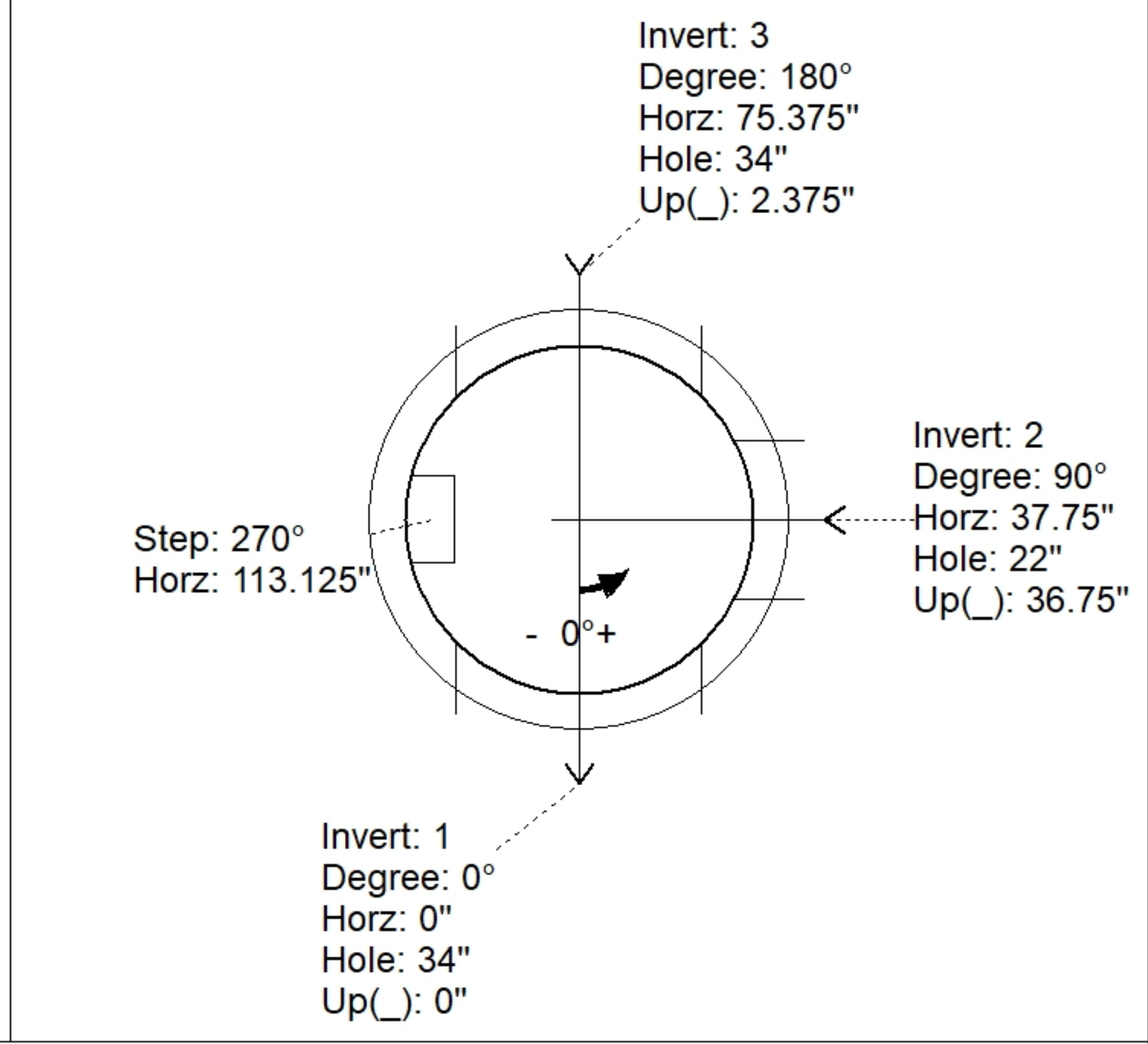
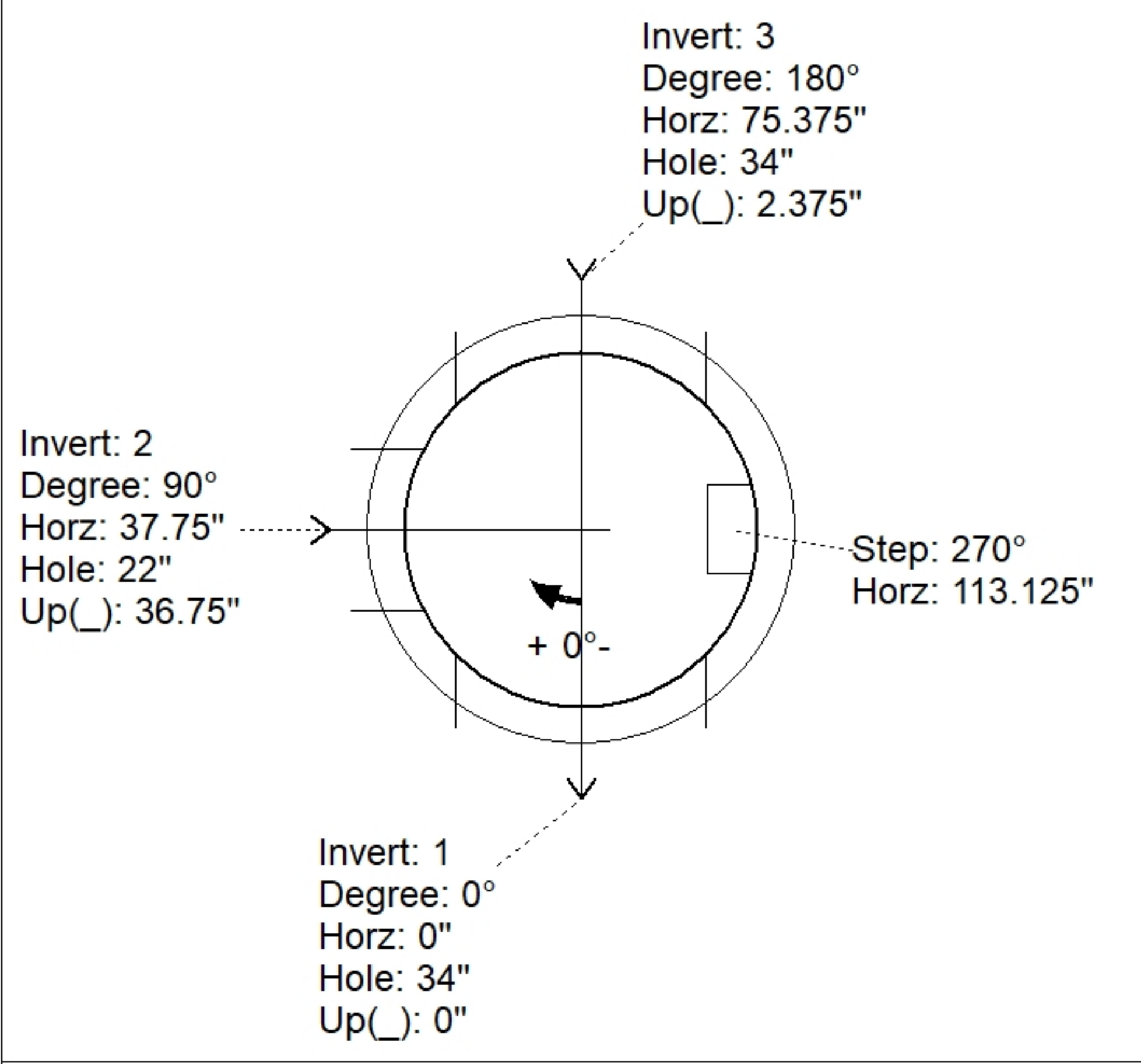
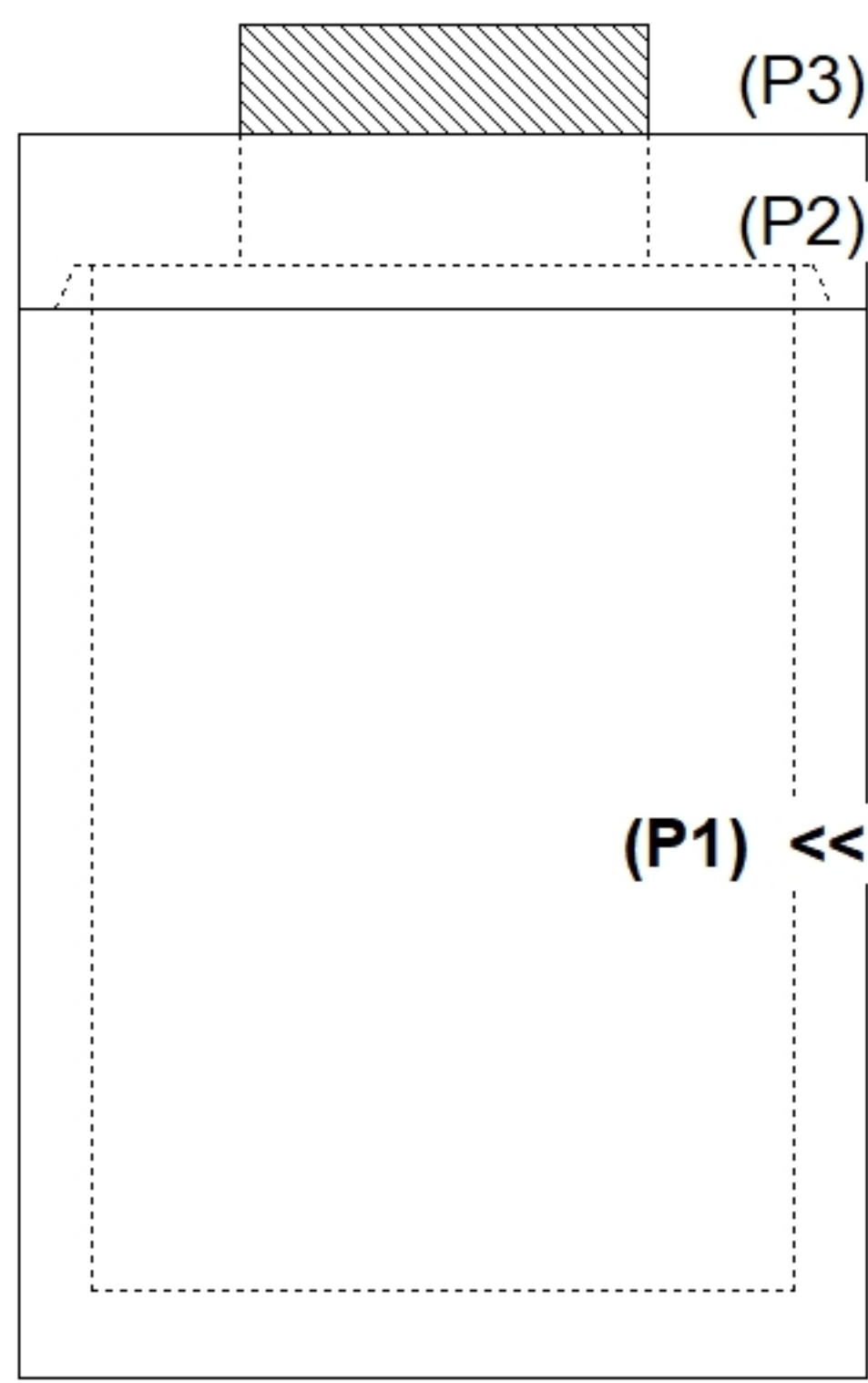

INSIDE WALL DIMENSIONS

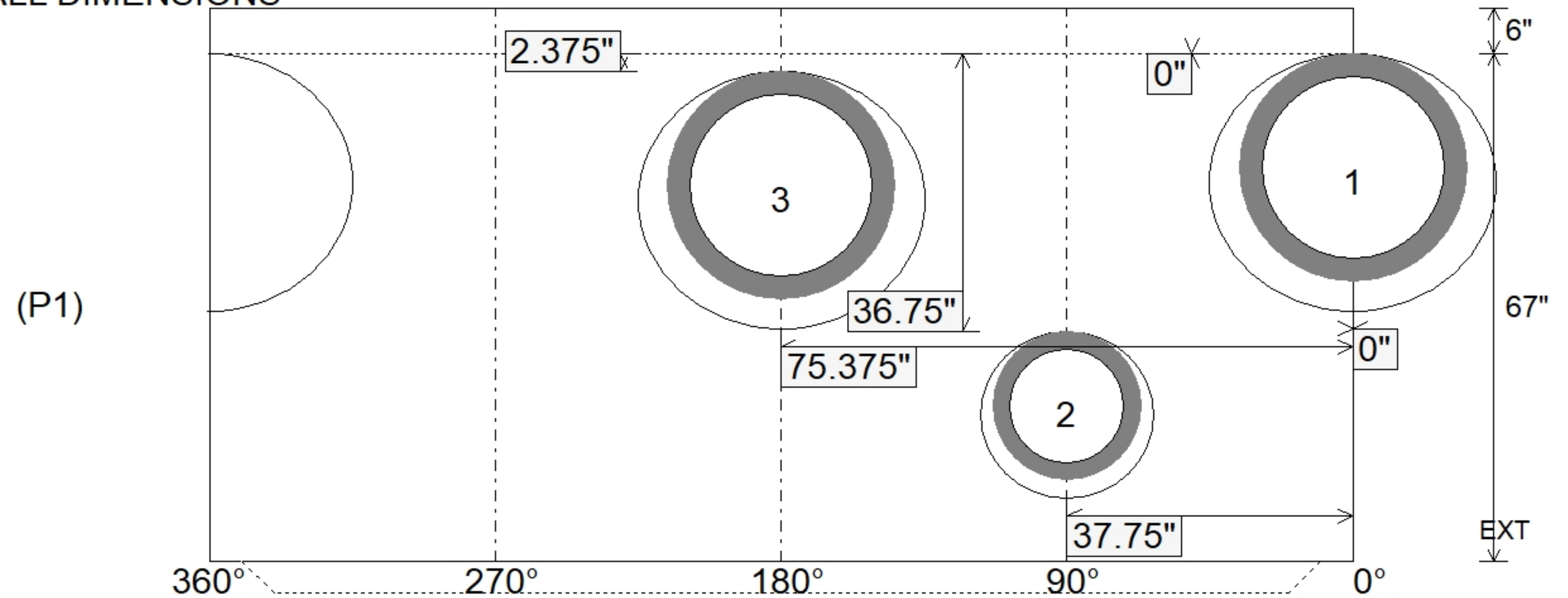

Coating (Int): Coating (Ext):	Seam Up: Tongue Seam Dn: n/a	Wall Thickness: 5" Floor Height: 6"	Height (Int): 67" Height (Ext): 73"	Weight (Net): 5016 lb Volume (Net): 1.28cu.yd
----------------------------------	---------------------------------	--	--	--