

Job Name: 24-2057B The Village At Lemon Mill Sanitary
 Job Location: Georgetown, KY
 Contractor: C Squared Contracting LLC

Plant: Beaver Dam

Tech: J. Coppage

10/14/2025 12:32:48 PM

PC: C. Goff



Structure ID: SSMH-B1-1 0+76.04

P1 MH048BA36

MH BASE

- P4) 24" - CASTING HEIGHT - 7"
- P3) 24" - GRADE RING - 6"
- P2) 48" - ECC CONE w/ 24" HOLE NO STEP - 42"
- P1) 48" - MH BASE - 36"
- 1) JOINT WRAP PRIMER - CONSEAL CS-75 (1 gal.)
- 1) JOINT WRAP - 0.065"x6"x50' CONSEAL CS212
- 1) 48" - MH INVERT CHANNEL - FULL HEIGHT
- 1) CASTING - HOE MC-375 F/C GMWSS
- 1) 48" - DBL 1"x14.5' Butyl (2x)
- 1) A-Lok - 0285
- 1) A-Lok - 0200

- 0 lb
- 405 lb
- 3000 lb
- 3797 lb
- 0 lb
- 0 lb
- 1440 lb
- 271 lb
- 0 lb
- 1 lb
- 1 lb

Structure Notes:

1. JR HOE MC-375 GMWSS PROVIDED BY ICAST.
2. PER ASTM C478 SPECIFICATIONS.
3. CONCRETE = 4,000 PSI AT 28 DAYS.
4. REINFORCING PER ASTM A615 (GRADE 60).
 - CONE (As .12)
 - RISER/WALLS (As .12)
 - FLOOR (As .31) #5 BARS AT 12" C.C.E.W.
5. ****NO STEPS****

Structure Total: 8915 lb

Rim: 869' Rim to Invert: 7.45' Slack: 0.404" Sump: 2.004" Step Position:

Position	Elev	Angle	Ext. (cw)	Pipe	Pipe OD	Connector	Hole	Horz Size	Up ()	Offset
Invert 1	861.55'	0°	0"	8" PVC SDR35	8.5"	A-Lok 0285	9.75"	9.818"	1.129"	0"
Invert 2	861.65'	92°	46.565"	6" PVC SDR35	6.25"	A-Lok 0200	7"	7.025"	2.704"	0"
Invert 3										
Invert 4										
Invert 5										
Invert 6										
Invert 7										
Invert 8										

RIGHT-SIDE UP VIEW (int. dimensions)

UPSIDE-DOWN VIEW (int. dimensions)

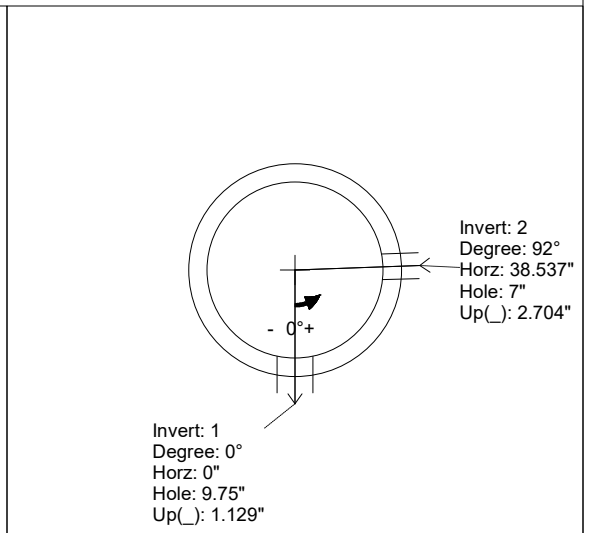
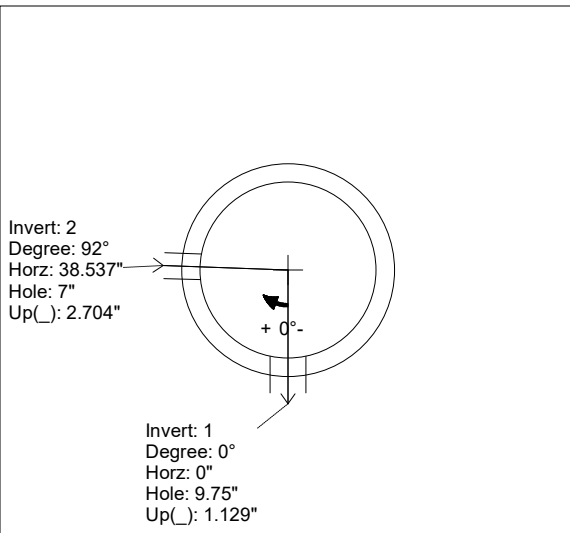
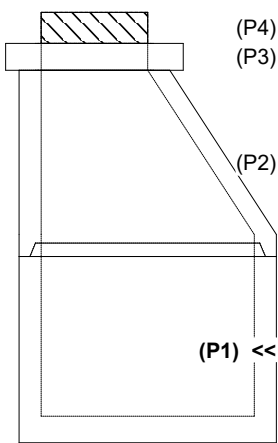

INSIDE WALL DIMENSIONS

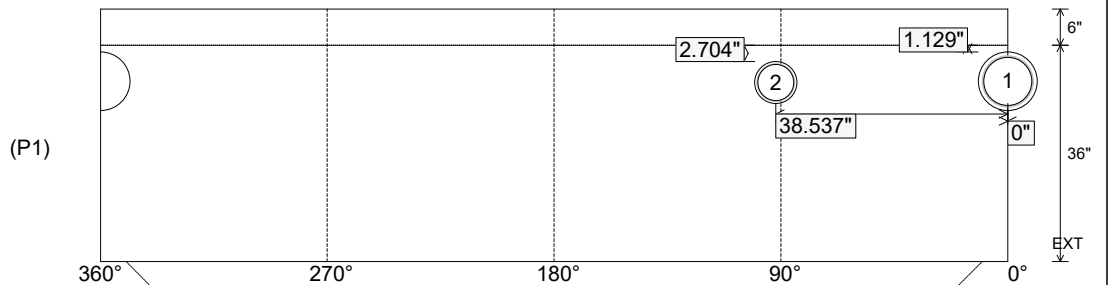

Coating (Int):
Coating (Ext):

Seam Up: Tongue
Seam Dn: n/a

Wall Thickness: 5"
Floor Height: 6"

Height (Int): 36"
Height (Ext): 42"

Weight (Net): 3797 lb
Volume (Net): 0.97cu.yd

Job Name: 24-2057B The Village At Lemon Mill Sanitary
 Job Location: Georgetown, KY
 Contractor: C Squared Contracting LLC

Plant: Beaver Dam
 10/14/2025 12:32:48 PM

Tech: J. Coppage
 PC: C. Goff



Structure ID: SSMH-B1-1 0+76.04

P1 MH048BA36

MH BASE

- P4) 24" - CASTING HEIGHT - 7"
- P3) 24" - GRADE RING - 6"
- P2) 48" - ECC CONE w/ 24" HOLE NO STEP - 42"
- P1) 48" - MH BASE - 36"
- 1) JOINT WRAP PRIMER - CONSEAL CS-75 (1 gal.)
- 1) JOINT WRAP - 0.065"x6"x50' CONSEAL CS212
- 1) 48" - MH INVERT CHANNEL - FULL HEIGHT
- 1) CASTING - HOE MC-375 F/C GMWSS
- 1) 48" - DBL 1"x14.5' Butyl (2x)
- 1) A-Lok - 0285
- 1) A-Lok - 0200

0 lb
 405 lb
 3000 lb
 3797 lb
 0 lb
 0 lb
 1440 lb
 271 lb
 0 lb
 1 lb
 1 lb

Structure Notes:

1. JR HOE MC-375 GMWSS PROVIDED BY ICAST.
2. PER ASTM C478 SPECIFICATIONS.
3. CONCRETE = 4,000 PSI AT 28 DAYS.
4. REINFORCING PER ASTM A615 (GRADE 60).
 - CONE (As .12)
 - RISER/WALLS (As .12)
 - FLOOR (As .31) #5 BARS AT 12" C.C.E.W.
5. ****NO STEPS****

Structure Total: 8915 lb

**INVERT CHANNEL DRAWING
 FULL HEIGHT INVERT**

Rim: 869' Rim to Invert: 7.45' Slack: 0.404" Sump: 2.004" Step Position:

Position	Elev	Angle	Ext. (cw)	Pipe	Pipe OD	Connector	Hole	Horz Size	Up ()	Offset
Invert 1	861.55'	0°	0"	8" PVC SDR35	8.5"	A-Lok 0285	9.75"	9.818"	1.129"	0"
Invert 2	861.65'	92°	46.565"	6" PVC SDR35	6.25"	A-Lok 0200	7"	7.025"	2.704"	0"
Invert 3										
Invert 4										
Invert 5										
Invert 6										
Invert 7										
Invert 8										

RIGHT-SIDE UP VIEW (int. dimensions)

UPSIDE-DOWN VIEW (int. dimensions)

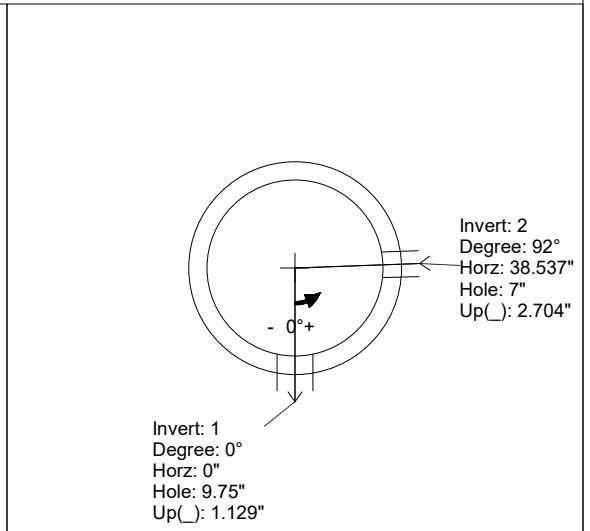
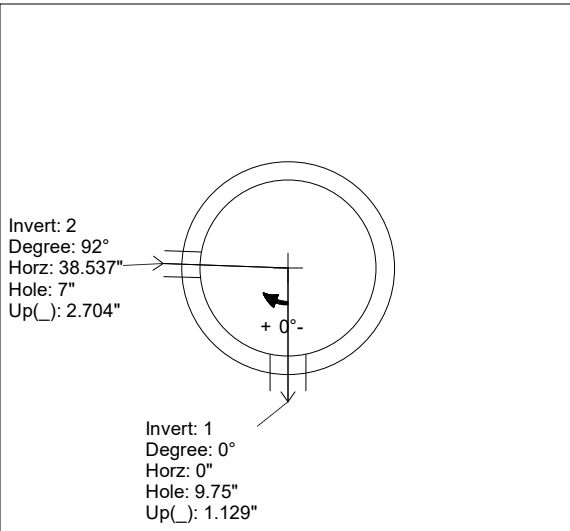
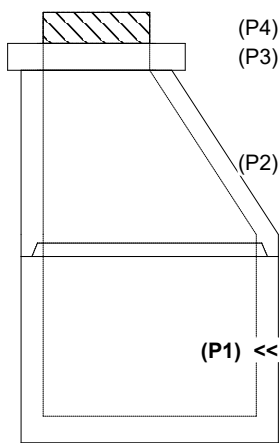

INSIDE WALL DIMENSIONS

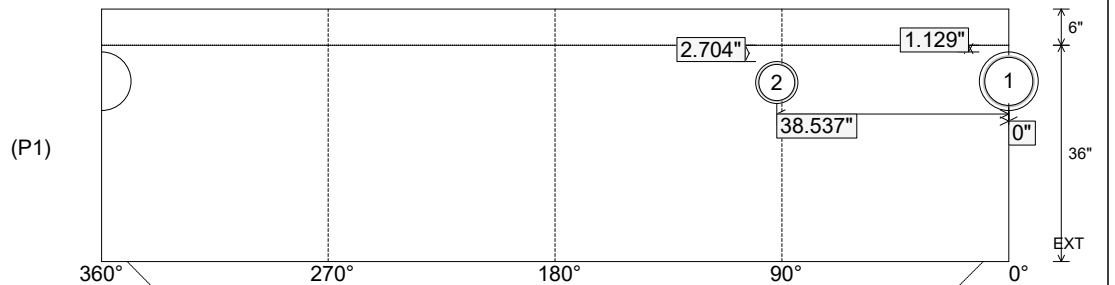

Coating (Int):
 Coating (Ext):

Seam Up: Tongue
 Seam Dn: n/a

Wall Thickness: 5"
 Floor Height: 6"

Height (Int): 36"
 Height (Ext): 42"

Weight (Net): 3797 lb
 Volume (Net): 0.97cu.yd