

Job Name: 24-2057B The Village At Lemon Mill Sanitary  
 Job Location: Georgetown, KY  
 Contractor: C Squared Contracting LLC

Plant: Beaver Dam  
 10/14/2025 12:32:46 PM

Tech: J. Coppage  
 PC: C. Goff



**Structure ID: SSMH-A1-1 0+55.39**

**P1 MH048BA30**

**MH BASE**

- P4) 24" - CASTING HEIGHT - 7"
- P3) 48" - ECC CONE w/ 24" HOLE NO STEP - 24"
- P2) 48" - MH RISER - 36"
- P1) 48" - MH BASE - 30"
- 1) JOINT WRAP PRIMER - CONSEAL CS-75 (1 gal.)
- 1) JOINT WRAP - 0.065"x6"x50' CONSEAL CS212
- 1) 48" - MH INVERT CHANNEL - FULL HEIGHT
- 1) CASTING - HOE MC-375 F/C GMWSS
- 2) 48" - DBL 1"x14.5' Butyl (2x)
- 3) A-Lok - 0285

0 lb  
 1550 lb  
 2515 lb  
 3331 lb  
 0 lb  
 0 lb  
 1440 lb  
 271 lb  
 0 lb  
 3 lb  
 -----  
 Structure Total: 9110 lb

**Structure Notes:**

1. JR HOE MC-375 GMWSS PROVIDED BY ICAST.
2. PER ASTM C478 SPECIFICATIONS.
3. CONCRETE = 4,000 PSI AT 28 DAYS.
4. REINFORCING PER ASTM A615 (GRADE 60).  
 - CONE (As .12)  
 - RISER/WALLS (As .12)  
 - FLOOR (As .31) #5 BARS AT 12" C.C.E.W.
5. \*\*NO STEPS\*\*

Rim: 862.6' Rim to Invert: 8.14' Slack: 2.684" Sump: 2.004" Step Position:

Position	Elev	Angle	Ext. (cw)	Pipe	Pipe OD	Connector	Hole	Horz Size	Up ( )	Offset
Invert 1	854.46'	0°	0"	8" PVC SDR35	8.5"	A-Lok 0285	9.75"	9.818"	1.129"	0"
Invert 2	855.59'	95°	48.084"	8" PVC SDR35	8.5"	A-Lok 0285	9.75"	9.818"	14.689"	0"
Invert 3	854.56'	185°	93.637"	8" PVC SDR35	8.5"	A-Lok 0285	9.75"	9.818"	2.329"	0"
Invert 4										
Invert 5										
Invert 6										
Invert 7										
Invert 8										

RIGHT-SIDE UP VIEW (int. dimensions)

UPSIDE-DOWN VIEW (int. dimensions)

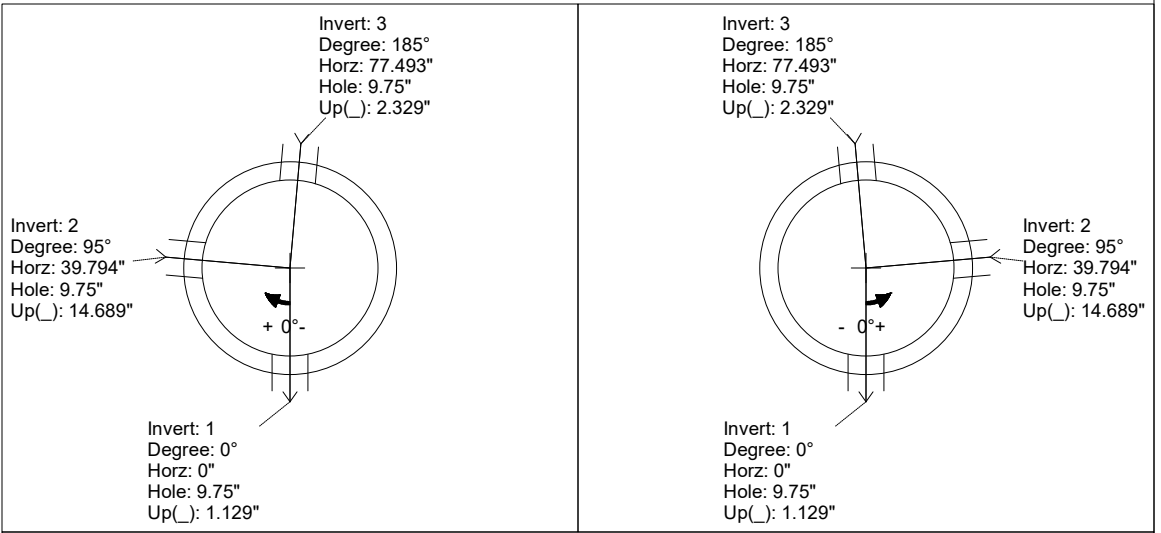

INSIDE WALL DIMENSIONS

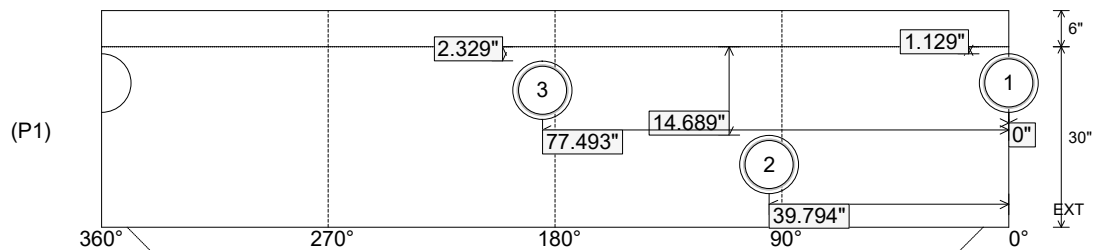

Coating (Int):  
 Coating (Ext):

Seam Up: Tongue  
 Seam Dn: n/a

Wall Thickness: 5"  
 Floor Height: 6"

Height (Int): 30"  
 Height (Ext): 36"

Weight (Net): 3331 lb  
 Volume (Net): 0.85cu.yd

Job Name: 24-2057B The Village At Lemon Mill Sanitary  
 Job Location: Georgetown, KY  
 Contractor: C Squared Contracting LLC

Plant: Beaver Dam

Tech: J. Coppage

10/14/2025 12:32:46 PM

PC: C. Goff



**Structure ID: SSMH-A1-1 0+55.39**

**P1 MH048BA30**

**MH BASE**

- P4) 24" - CASTING HEIGHT - 7"
- P3) 48" - ECC CONE w/ 24" HOLE NO STEP - 24"
- P2) 48" - MH RISER - 36"
- P1) 48" - MH BASE - 30"
- 1) JOINT WRAP PRIMER - CONSEAL CS-75 (1 gal.)
- 1) JOINT WRAP - 0.065"x6"x50' CONSEAL CS212
- 1) 48" - MH INVERT CHANNEL - FULL HEIGHT
- 1) CASTING - HOE MC-375 F/C GMWSS
- 2) 48" - DBL 1"x14.5' Butyl (2x)
- 3) A-Lok - 0285

0 lb  
 1550 lb  
 2515 lb  
 3331 lb  
 0 lb  
 0 lb  
 1440 lb  
 271 lb  
 0 lb  
 3 lb  
 -----  
 Structure Total: 9110 lb

**Structure Notes:**

1. JR HOE MC-375 GMWSS PROVIDED BY ICAST.
2. PER ASTM C478 SPECIFICATIONS.
3. CONCRETE = 4,000 PSI AT 28 DAYS.
4. REINFORCING PER ASTM A615 (GRADE 60).  
 - CONE (As .12)  
 - RISER/WALLS (As .12)  
 - FLOOR (As .31) #5 BARS AT 12" C.C.E.W.
5. \*\*NO STEPS\*\*

**INVERT CHANNEL DRAWING  
 FULL HEIGHT INVERT**

Rim: 862.6' Rim to Invert: 8.14' Slack: 2.684" Sump: 2.004" Step Position:

Position	Elev	Angle	Ext. (cw)	Pipe	Pipe OD	Connector	Hole	Horz Size	Up ( )	Offset
Invert 1	854.46'	0°	0"	8" PVC SDR35	8.5"	A-Lok 0285	9.75"	9.818"	1.129"	0"
Invert 2	855.59'	95°	48.084"	8" PVC SDR35	8.5"	A-Lok 0285	9.75"	9.818"	14.689"	0"
Invert 3	854.56'	185°	93.637"	8" PVC SDR35	8.5"	A-Lok 0285	9.75"	9.818"	2.329"	0"
Invert 4										
Invert 5										
Invert 6										
Invert 7										
Invert 8										

**RIGHT-SIDE UP VIEW (int. dimensions)**

**UPSIDE-DOWN VIEW (int. dimensions)**

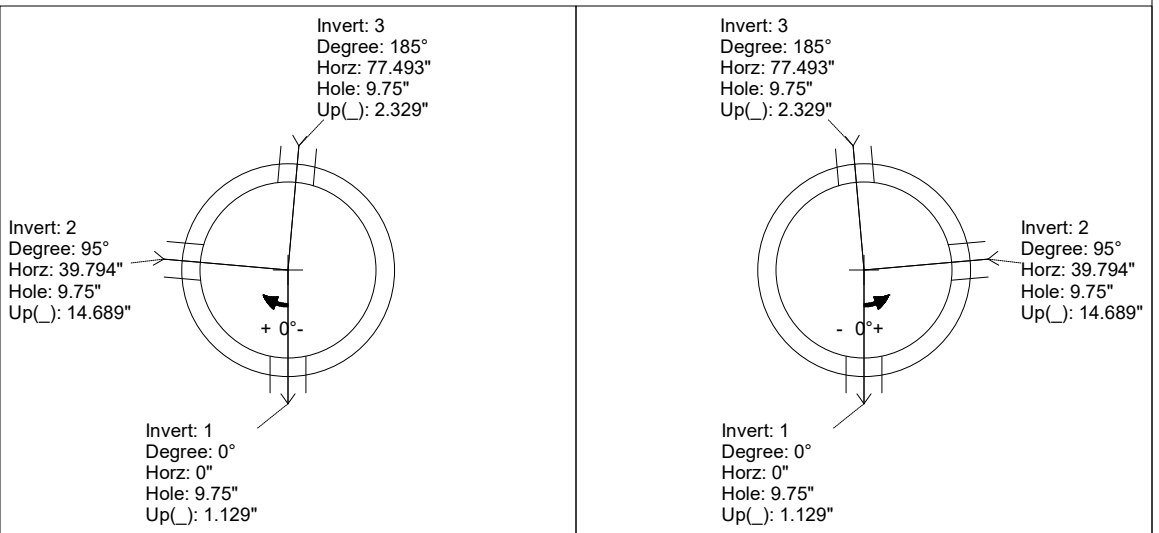

**INSIDE WALL DIMENSIONS**

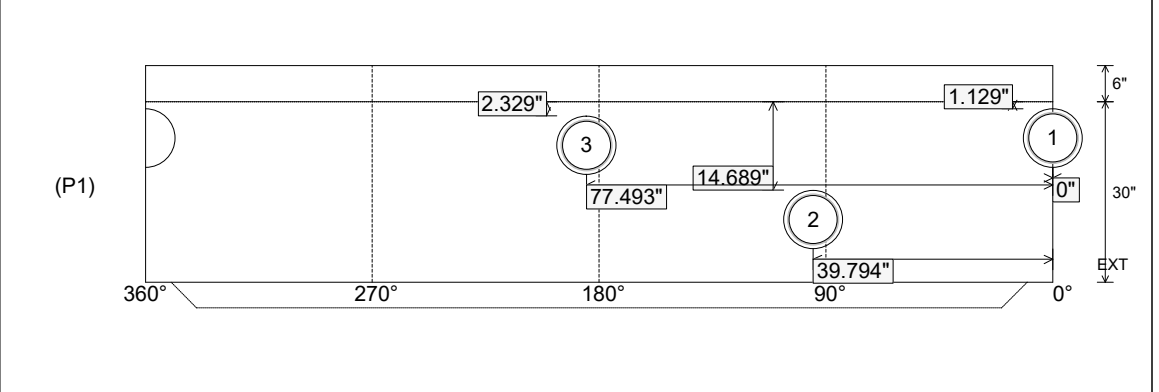

Coating (Int): Coating (Ext):	Seam Up: Tongue Seam Dn: n/a	Wall Thickness: 5" Floor Height: 6"	Height (Int): 30" Height (Ext): 36"	Weight (Net): 3331 lb Volume (Net): 0.85cu.yd
----------------------------------	---------------------------------	--	--	--