

Job Name: 24-2057B The Village At Lemon Mill Sanitary
 Job Location: Georgetown, KY
 Contractor: C Squared Contracting LLC

Plant: Beaver Dam
 10/14/2025 12:32:45 PM

Tech: J. Coppage
 PC: C. Goff



Structure ID: SSMH-A1 0+67.87

P1 MH060BA60

MH BASE

P5) 24" - CASTING HEIGHT - 7"	0 lb
P4) 48" - MH FLAT TOP w/ 24" ECC Hole - 12"	1561 lb
P3) 48" - MH RISER SPECIAL/CUST. HT - 22"	1537 lb
P2) 60" - MH Transition Slab 48" Hole - 13"	1928 lb
P1) 60" - MH BASE - 60"	8884 lb
1) JOINT WRAP - 0.065"x6"x50' CONSEAL CS212	0 lb
1) JOINT WRAP PRIMER - CONSEAL CS-75 (1 gal.)	0 lb
1) 60" - MH INVERT CHANNEL - FULL HEIGHT	2692 lb
1) CASTING - HOE MC-375 F/C GMWSS	271 lb
1) 60" - DBL 1"x14.5' Butyl (2x)	0 lb
2) 48" - DBL 1"x14.5' Butyl (2x)	0 lb
3) A-Lok - 0285	3 lb
Structure Total:	16875 lb

- Structure Notes:**
1. JR HOE MC-375 GMWSS PROVIDED BY ICAST.
 2. PER ASTM C478 SPECIFICATIONS.
 3. CONCRETE = 4,000 PSI AT 28 DAYS.
 4. REINFORCING PER ASTM A615 (GRADE 60).
 - CONE (As .12)
 - TRANS SLAB (As .62) #5 BARS AT 6" C.C.E.W.
 - RISER/WALLS (As .18)
 - FLOOR (As .31) #5 BARS AT 12" C.C.E.W.
 5. **NO STEPS**
 6. INTERNAL DROP BY OTHERS

Rim: 863.03' Rim to Invert: 9.38' Slack: 0.564" Sump: 2.004" Step Position:

Position	Elev	Angle	Ext. (cw)	Pipe	Pipe OD	Connector	Hole	Horz Size	Up ()	Offset
Invert 1	853.65'	0°	0"	8" PVC SDR35	8.5"	A-Lok 0285	9.75"	9.793"	1.129"	0"
Invert 2	854.18'	262°	164.619"	8" PVC SDR35	8.5"	A-Lok 0285	9.75"	9.793"	7.489"	0"
Invert 3	856.85'	92°	57.805"	8" PVC SDR35	8.5"	A-Lok 0285	9.75"	9.793"	39.529"	0"
Invert 4										
Invert 5										
Invert 6										
Invert 7										
Invert 8										

RIGHT-SIDE UP VIEW (int. dimensions)

UPSIDE-DOWN VIEW (int. dimensions)

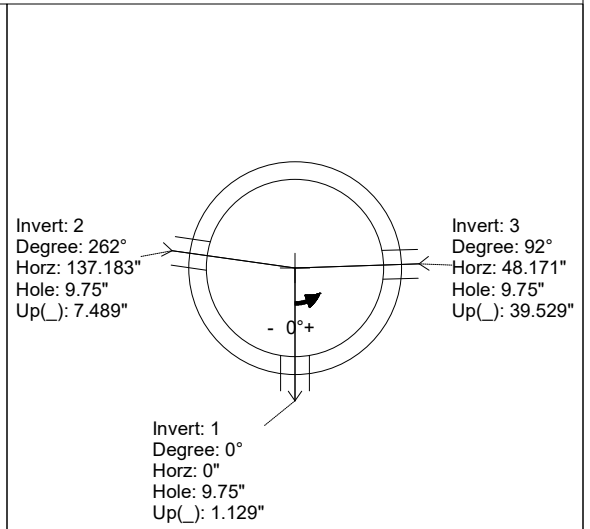
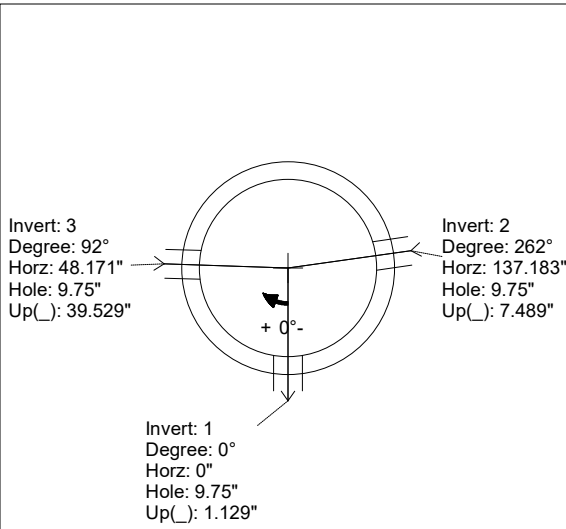
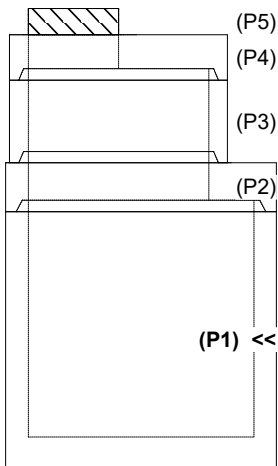

INSIDE WALL DIMENSIONS

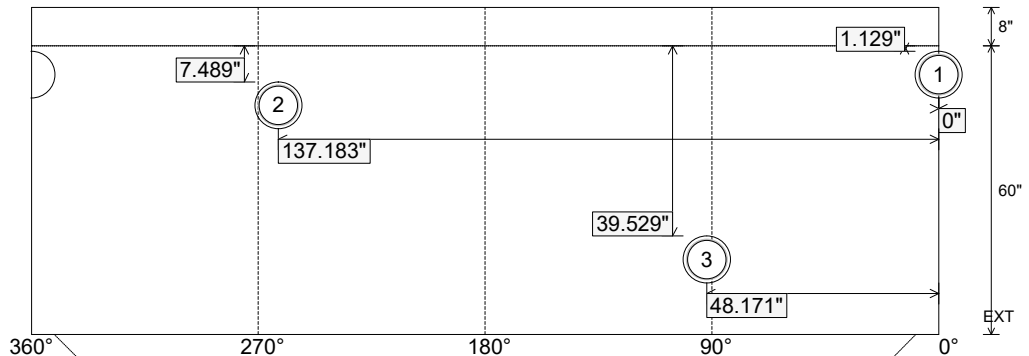

Coating (Int): Coating (Ext):	Seam Up: Tongue Seam Dn: n/a	Wall Thickness: 6" Floor Height: 8"	Height (Int): 60" Height (Ext): 68"	Weight (Net): 8884 lb Volume (Net): 2.27cu.yd
----------------------------------	---------------------------------	--	--	--

Job Name: 24-2057B The Village At Lemon Mill Sanitary
 Job Location: Georgetown, KY
 Contractor: C Squared Contracting LLC

Plant: Beaver Dam
 10/14/2025 12:32:45 PM

Tech: J. Coppage
 PC: C. Goff



Structure ID: SSMH-A1 0+67.87

P1 MH060BA60

MH BASE

- P5) 24" - CASTING HEIGHT - 7"
- P4) 48" - MH FLAT TOP w/ 24" ECC Hole - 12"
- P3) 48" - MH RISER SPECIAL/CUST. HT - 22"
- P2) 60" - MH Transition Slab 48" Hole - 13"
- P1) 60" - MH BASE - 60"
- 1) JOINT WRAP - 0.065"x6"x50' CONSEAL CS212
- 1) JOINT WRAP PRIMER - CONSEAL CS-75 (1 gal.)
- 1) 60" - MH INVERT CHANNEL - FULL HEIGHT
- 1) CASTING - HOE MC-375 F/C GMWSS
- 1) 60" - DBL 1"x14.5' Butyl (2x)
- 2) 48" - DBL 1"x14.5' Butyl (2x)
- 3) A-Lok - 0285

0 lb
 1561 lb
 1537 lb
 1928 lb
 8884 lb
 0 lb
 0 lb
 2692 lb
 271 lb
 0 lb
 0 lb
 3 lb

 Structure Total: 16875 lb

- Structure Notes:**
1. JR HOE MC-375 GMWSS PROVIDED BY ICAST.
 2. PER ASTM C478 SPECIFICATIONS.
 3. CONCRETE = 4,000 PSI AT 28 DAYS.
 4. REINFORCING PER ASTM A615 (GRADE 60).
 - CONE (As .12)
 - TRANS SLAB (As .62) #5 BARS AT 6" C.C.E.W.
 - RISER/WALLS (As .18)
 - FLOOR (As .31) #5 BARS AT 12" C.C.E.W.
 5. ****NO STEPS****
 6. INTERNAL DROP BY OTHERS

**INVERT CHANNEL DRAWING
 FULL HEIGHT INVERT**

Rim: 863.03' Rim to Invert: 9.38' Slack: 0.564" Sump: 2.004" Step Position:

Position	Elev	Angle	Ext. (cw)	Pipe	Pipe OD	Connector	Hole	Horz Size	Up ()	Offset
Invert 1	853.65'	0°	0"	8" PVC SDR35	8.5"	A-Lok 0285	9.75"	9.793"	1.129"	0"
Invert 2	854.18'	262°	164.619"	8" PVC SDR35	8.5"	A-Lok 0285	9.75"	9.793"	7.489"	0"
Invert 3	856.85'	92°	57.805"	8" PVC SDR35	8.5"	A-Lok 0285	9.75"	9.793"	39.529"	0"
Invert 4										
Invert 5										
Invert 6										
Invert 7										
Invert 8										

RIGHT-SIDE UP VIEW (int. dimensions)

UPSIDE-DOWN VIEW (int. dimensions)

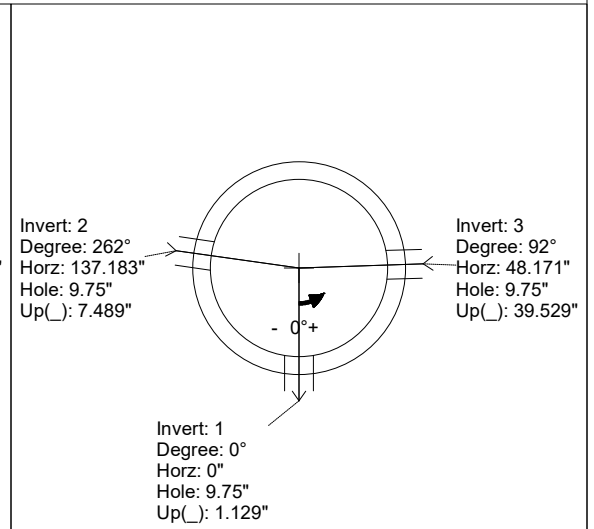
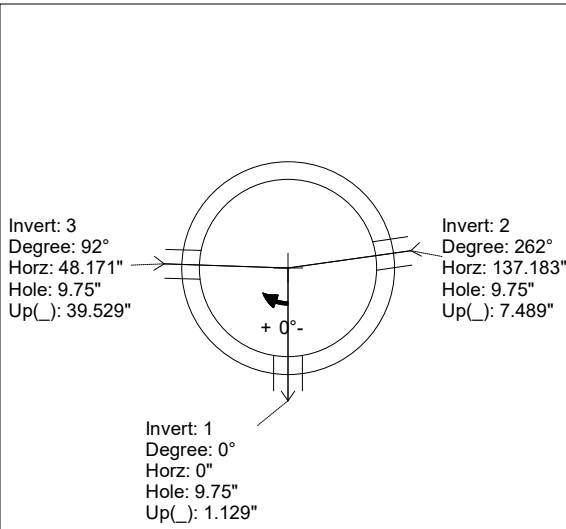
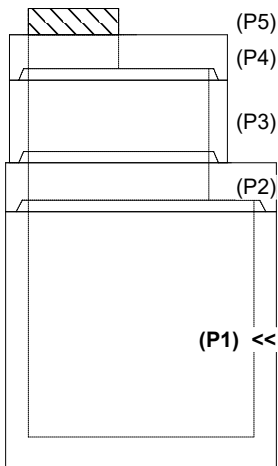

INSIDE WALL DIMENSIONS

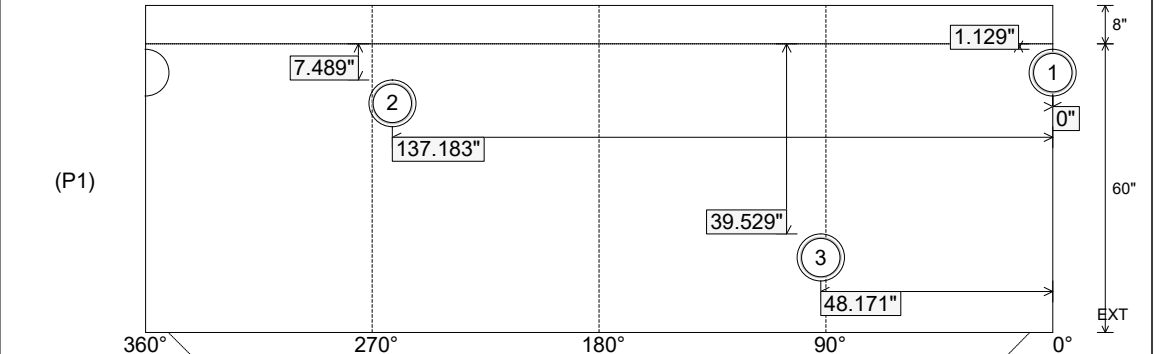

Coating (Int): Coating (Ext):	Seam Up: Tongue Seam Dn: n/a	Wall Thickness: 6" Floor Height: 8"	Height (Int): 60" Height (Ext): 68"	Weight (Net): 8884 lb Volume (Net): 2.27cu.yd
----------------------------------	---------------------------------	--	--	--