

Job Name: 24-1632 - KYTC Letting Call 100 (241306) Sanitary  
 Job Location: Jackson, KY 41339  
 Contractor: Triton Construction, Inc.

Plant: Beaver Dam, KY  
 1/9/2026 7:04:58 AM

Tech: K. Cardwell  
 PC: C. Goff



**Structure ID: MH-N411 Base Remake (1-8-26)**

**P1 MH060BAEVFX**

**MH BASE w/FLANGE/XYPEX T/n**

- P6) 24" - CASTING HEIGHT - 7" 0 lb
- P5) 48" - ECC XYPEX CONE w/ 24" HOLE F/G - 42" 3116 lb
- P4) 48" - MH RISER w/XYPEX T/G - 60" 4192 lb
- P3) 48" - MH RISER w/XYPEX SPECIAL T/G - 60" 4144 lb
- P2) 60" - XYPEX MH FT REDUCER 48" HOLE T/G - 13" 1888 lb
- P1) 60" - MH BASE w/FLANGE/XYPEX T/n - 36" 7453 lb
- 1) JOINT WRAP PRIMER - CONSEAL CS-75 (1 gal.) 0 lb
- 1) JOINT WRAP - 0.065"x6"x50' CONSEAL CS212 0 lb
- 1) SECONDARY POUR - EXTENDED FLANGE 0 lb
- 1) 60" - MH INVERT CHANNEL w/XYPEX - FULL HEIGHT 2962 lb
- 1) CASTING - HOE MC-350 F/C Sanitary 305 lb
- 1) 60" - Conseal CS-102 1.00" (Double) 0 lb
- 3) 48" - Conseal CS-102 1.00" (Double) 0 lb
- 2) PSX - 16M DD 16 lb
- 1) PSX - 12-08 NYLO 8 lb
- 17) MH Step ML-10-TDS-NCR - 10" 0 lb

- Structure Notes:**  
 STATION: 44+77.58
1. PER KYTC & ASTM C-478 SPECIFICATIONS
  2. CONCRETE: 5,000 PSI AT 28 DAYS
  3. REINFORCEMENT: PER ASTM A615
  4. INVERT CHANNEL REQUIRED
  5. XYPEX ADMIXTURE REQUIRED
  6. TIDFLEX DUCKBILL CHECK VALVE TO BE INSTALLED BY ICAST INSIDE OF MANHOLE OVER OPENING FOR INVERT 2
  7. BASE REMAKE ONLY

Structure Total: 24084 lb

**FIRST POUR (BASE): 6,100 LBS**  
**SECOND POUR (EXT. FLANGE): 1,353 LBS**

Rim: 730' Rim to Invert: 18' Slack: 0" Sump: 2" Step Position: 0°

Position	Elev	Angle	Ext. (cw)	Pipe	Pipe OD	Connector	Hole	Horz Size	Up (")	Offset
Invert 1	712'	0°	0"	12" PVC SDR35	12.5"	PSX 16M DD	16"	16.196"	0"	0"
Invert 2	713.1'	124°	77.911"	12" PVC SDR35	12.5"	PSX 16M DD	16"	16.196"	13.2"	0"
Invert 3										
Invert 4										
Invert 5										
Invert 6										
Invert 7										
Invert 8										

RIGHT-SIDE UP VIEW (int. dimensions)

UPSIDE-DOWN VIEW (int. dimensions)

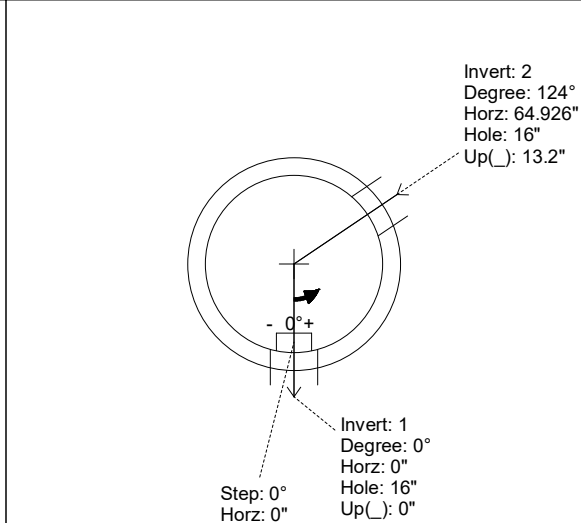
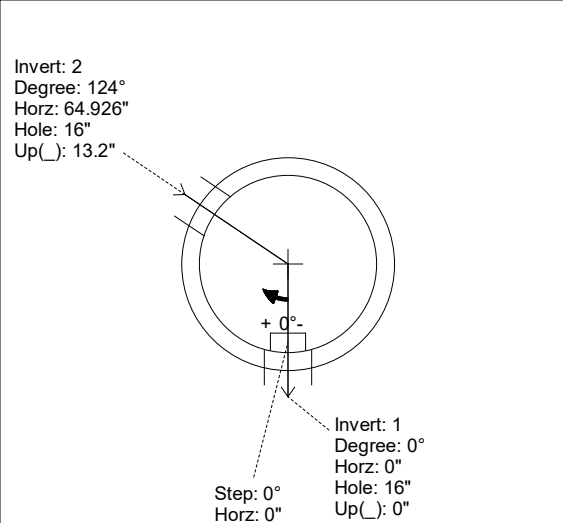
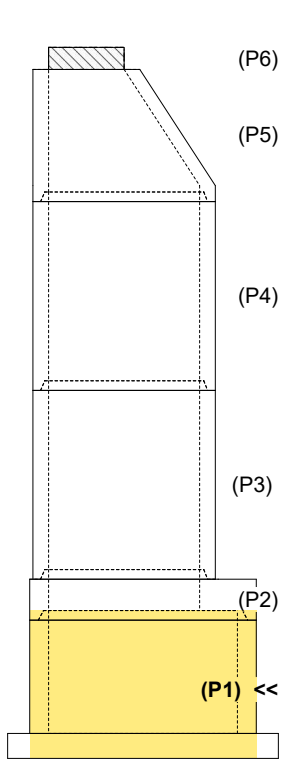

INSIDE WALL DIMENSIONS

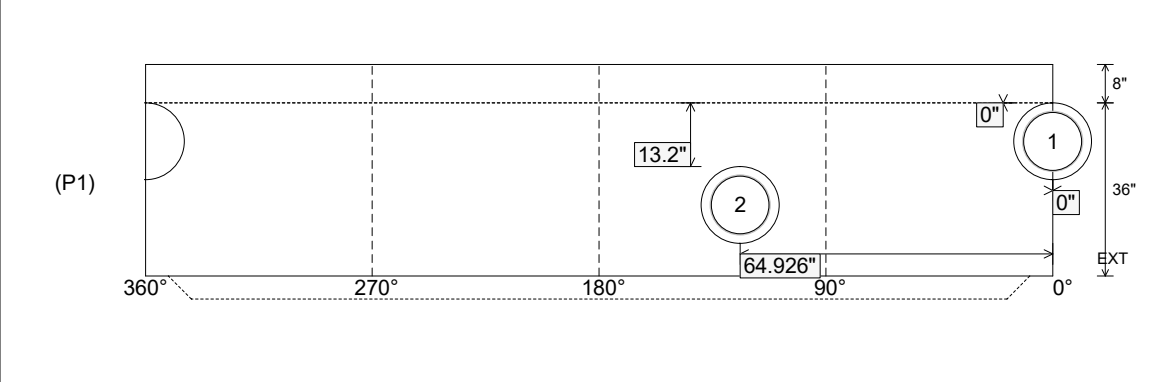

Coating (Int): Coating (Ext):	Seam Up: Tongue Seam Dn: n/a	Wall Thickness: 6" Floor Height: 8"	Height (Int): 36" Height (Ext): 44"	Weight (Net): 7453 lb Volume (Net): 1.9cu.yd
----------------------------------	---------------------------------	--	--	---

Job Name: 24-1632 - KYTC Letting Call 100 (241306) Sanitary  
 Job Location: Jackson, KY 41339  
 Contractor: Triton Construction, Inc.

Plant: Beaver Dam, KY  
 1/9/2026 7:04:58 AM

Tech: K. Cardwell  
 PC: C. Goff



**Structure ID: MH-N411 Base Remake (1-8-26)**

**P1 MH060BAEVFX**

**MH BASE w/FLANGE/XYPEX T/n**

- P6) 24" - CASTING HEIGHT - 7" 0 lb
- P5) 48" - ECC XYPEX CONE w/ 24" HOLE F/G - 42" 3116 lb
- P4) 48" - MH RISER w/XYPEX T/G - 60" 4192 lb
- P3) 48" - MH RISER w/XYPEX SPECIAL T/G - 60" 4144 lb
- P2) 60" - XYPEX MH FT REDUCER 48" HOLE T/G - 13" 1888 lb
- P1) 60" - MH BASE w/FLANGE/XYPEX T/n - 36" 7453 lb
- 1) JOINT WRAP PRIMER - CONSEAL CS-75 (1 gal.) 0 lb
- 1) JOINT WRAP - 0.065"x6"x50' CONSEAL CS212 0 lb
- 1) SECONDARY POUR - EXTENDED FLANGE 0 lb
- 1) 60" - MH INVERT CHANNEL w/XYPEX - FULL HEIGHT 2962 lb
- 1) CASTING - HOE MC-350 F/C Sanitary 305 lb
- 1) 60" - Conseal CS-102 1.00" (Double) 0 lb
- 3) 48" - Conseal CS-102 1.00" (Double) 0 lb
- 2) PSX - 16M DD 16 lb
- 1) PSX - 12-08 NYLO 8 lb
- 17) MH Step ML-10-TDS-NCR - 10" 0 lb

**Structure Notes:**  
 STATION: 44+77.58  
 1. PER KYTC & ASTM C-478 SPECIFICATIONS  
 2. CONCRETE: 5,000 PSI AT 28 DAYS  
 3. REINFORCEMENT: DRILL & DOWEL #5 BAR @ 12" C.C. E.W. (GRADE 60) OUT OF BASE FLOOR FOR EXTENDED FLANGE POUR TIE-IN - MIN. 4" PENETRATION INTO BASE FLOOR & 2" MIN. REBAR CLEARANCE (TYP)  
 4. INVERT CHANNEL REQUIRED  
 5. XYPEX ADMIXTURE REQUIRED  
 6. TIDEFLEX DUCKBILL CHECK VALVE TO BE INSTALLED BY ICAST INSIDE OF MANHOLE OVER OPENING FOR INVERT 2  
 7. BASE REMAKE ONLY

Structure Total: 24084 lb

**FIRST POUR (BASE): 6,100 LBS**  
**SECOND POUR (EXT. FLANGE): 1,353 LBS**

Rim: 730'	Rim to Invert: 18'	Slack: 0"	Sump: 2"	Step Position: 0°						
Position	Elev	Angle	Ext. (cw)	Pipe	Pipe OD	Connector	Hole	Horz Size	Up ( )	Offset
Invert 1	712'	0°	0"	12" PVC SDR35	12.5"	PSX 16M DD	16"	16.196"	0"	0"
Invert 2	713.1'	124°	77.911"	12" PVC SDR35	12.5"	PSX 16M DD	16"	16.196"	13.2"	0"
Invert 3										
Invert 4										
Invert 5										
Invert 6										
Invert 7										
Invert 8										

RIGHT-SIDE UP VIEW (int. dimensions)

UPSIDE-DOWN VIEW (int. dimensions)

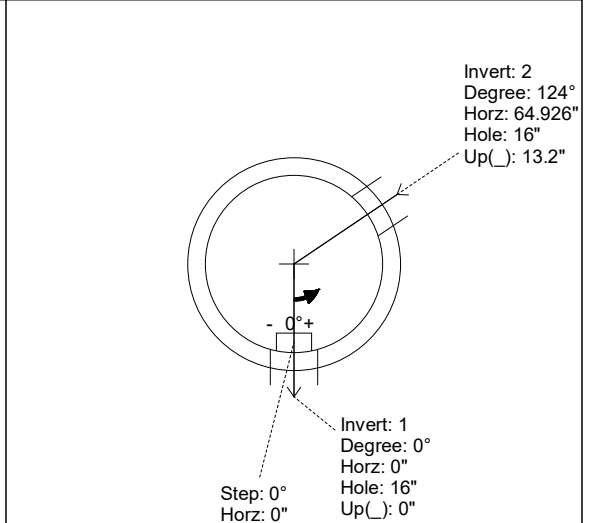
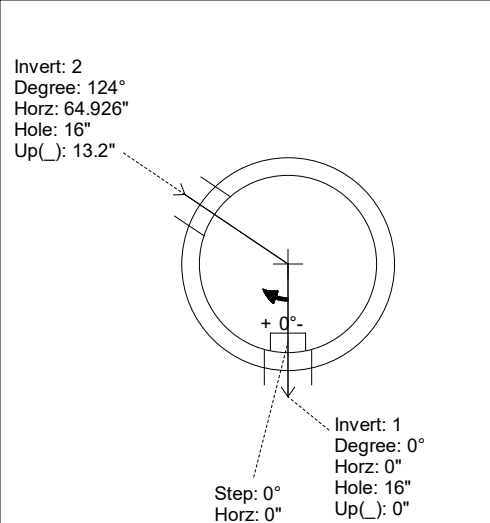
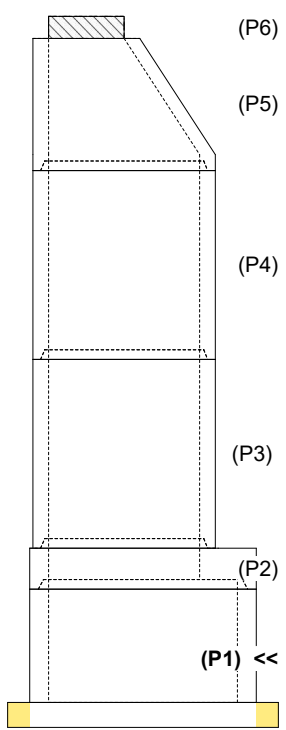

INSIDE WALL DIMENSIONS

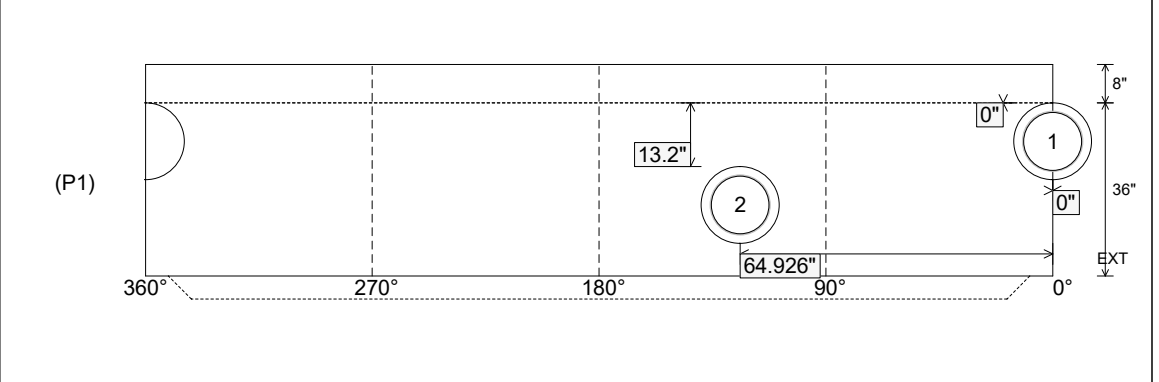

Coating (Int): Coating (Ext):	Seam Up: Tongue Seam Dn: n/a	Wall Thickness: 6" Floor Height: 8"	Height (Int): 36" Height (Ext): 44"	Weight (Net): 7453 lb Volume (Net): 1.9cu.yd
----------------------------------	---------------------------------	--	--	---

Job Name: 24-1632 - KYTC Letting Call 100 (241306) Sanitary  
 Job Location: Jackson, KY 41339  
 Contractor: Triton Construction, Inc.

Plant: Beaver Dam, KY  
 1/9/2026 7:04:58 AM

Tech: K. Cardwell  
 PC: C. Goff



**Structure ID: MH-N411 Base Remake (1-8-26)**

**P1 MH060BAEVFX**

**MH BASE w/FLANGE/XYPEX T/n**

- P6) 24" - CASTING HEIGHT - 7" 0 lb
  - P5) 48" - ECC XYPEX CONE w/ 24" HOLE F/G - 42" 3116 lb
  - P4) 48" - MH RISER w/XYPEX T/G - 60" 4192 lb
  - P3) 48" - MH RISER w/XYPEX SPECIAL T/G - 60" 4144 lb
  - P2) 60" - XYPEX MH FT REDUCER 48" HOLE T/G - 13" 1888 lb
  - P1) 60" - MH BASE w/FLANGE/XYPEX T/n - 36" 7453 lb
  - 1) JOINT WRAP PRIMER - CONSEAL CS-75 (1 gal.) 0 lb
  - 1) JOINT WRAP - 0.065"x6"x50' CONSEAL CS212 0 lb
  - 1) SECONDARY POUR - EXTENDED FLANGE 0 lb
  - 1) 60" - MH INVERT CHANNEL w/XYPEX - FULL HEIGHT 2962 lb
  - 1) CASTING - HOE MC-350 F/C Sanitary 305 lb
  - 1) 60" - Conseal CS-102 1.00" (Double) 0 lb
  - 3) 48" - Conseal CS-102 1.00" (Double) 0 lb
  - 2) PSX - 16M DD 16 lb
  - 1) PSX - 12-08 NYLO 8 lb
  - 17) MH Step ML-10-TDS-NCR - 10" 0 lb
- Structure Total: 24084 lb

- Structure Notes:**  
 STATION: 44+77.58
1. PER KYTC & ASTM C-478 SPECIFICATIONS
  2. CONCRETE: 5,000 PSI AT 28 DAYS
  3. REINFORCEMENT: PER ASTM A615
  4. INVERT CHANNEL REQUIRED
  5. XYPEX ADMIXTURE REQUIRED
  6. TIDFLEX DUCKBILL CHECK VALVE TO BE INSTALLED BY ICAST INSIDE OF MANHOLE OVER OPENING FOR INVERT 2
  7. BASE REMAKE ONLY

Rim: 730' Rim to Invert: 18' Slack: 0" Sump: 2" Step Position: 0°

Position	Elev	Angle	Ext. (cw)	Pipe	Pipe OD	Connector	Hole	Horz Size	Up ( )	Offset
Invert 1	712'	0°	0"	12" PVC SDR35	12.5"	PSX 16M DD	16"	16.196"	0"	0"
Invert 2	713.1'	124°	77.911"	12" PVC SDR35	12.5"	PSX 16M DD	16"	16.196"	13.2"	0"
Invert 3										
Invert 4										
Invert 5										
Invert 6										
Invert 7										
Invert 8										

RIGHT-SIDE UP VIEW (int. dimensions)

UPSIDE-DOWN VIEW (int. dimensions)

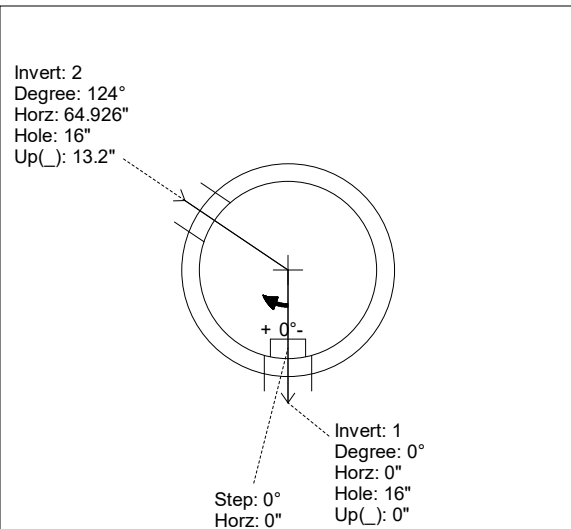
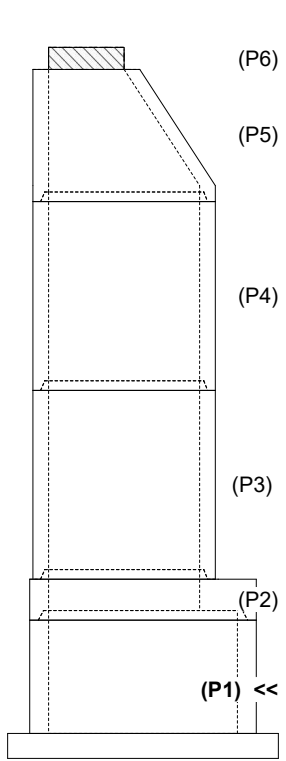

INVERT CHANNEL  
DRAWING

INSIDE WALL DIMENSIONS

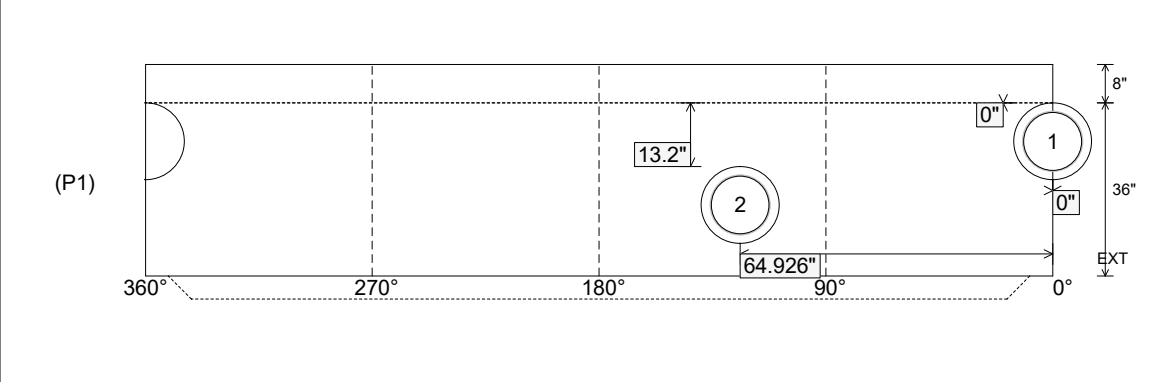

Coating (Int): Coating (Ext):	Seam Up: Tongue Seam Dn: n/a	Wall Thickness: 6" Floor Height: 8"	Height (Int): 36" Height (Ext): 44"	Weight (Net): 7453 lb Volume (Net): 1.9cu.yd
----------------------------------	---------------------------------	--	--	---