

Job Name: 24-1632 - KYTC Letting Call 100 (241306) Sanitary
 Job Location: Jackson, KY 41339
 Contractor: Triton Construction, Inc.

Plant: Beaver Dam, KY
 1/23/2026 8:01:31 AM

Tech: K. Cardwell
 PC: C. Goff



Structure ID: MH-K105

P1 MH048BAEVFx

MH BASE EF/Xypex Cust. Ht. 08"F (08"EF =74"OD)

P4) 24" - CASTING HEIGHT - 7"	0 lb
P3) 48" - ECC XYPEX CONE w/ 24" HOLE F/G - 42"	3116 lb
P2) 48" - MH RISER w/XYPEX T/G - 60"	4192 lb
P1) 48" - MH BASE EF/Xypex Cust. Ht. 08"F (08"EF =74"OD) T/n - 24"	4468 lb
1) JOINT WRAP PRIMER - CONSEAL CS-75 (1 gal.)	0 lb
1) JOINT WRAP - 0.065"x6"x50' CONSEAL CS212	0 lb
1) 48" - MH INVERT CHANNEL w/XYPEX - FULL HEIGHT	1440 lb
1) ADMIXTURE XYPEX C-500 NF RED	0 lb
1) CASTING - HOE MC-350 F/C Sanitary	305 lb
2) 48" - Conseal CS-102 1.00" (Double)	0 lb
2) PSX - 12-08 NYLO	16 lb
11) MH Step ML-10-TDS-NCR - 10"	0 lb
Structure Total:	13537 lb

Structure Notes:
 STATION: 559+26.31
 1. PER KYTC & ASTM C-478 SPECIFICATIONS
 2. CONCRETE: 5,000 PSI AT 28 DAYS
 3. REINFORCEMENT: PER ASTM A615
 4. INVERT CHANNEL REQUIRED
 5. XYPEX ADMIXTURE REQUIRED
 6. STEPS AT 0 DEGREES
 7. HOE MC-350 FRAME & COVER "SANITARY" SUPPLIED BY ICAST

Rim: 743.03' Rim to Invert: 11.06' Slack: 1.72" Sump: 2" Step Position: 0°

Position	Elev	Angle	Ext. (cw)	Pipe	Pipe OD	Connector	Hole	Horz Size	Up ()	Offset
Invert 1	731.97'	0°	0"	8" PVC SDR35	8.5"	PSX 12-08 NYLO	12"	12.129"	0"	0"
Invert 2	732.07'	237°	119.956"	8" PVC SDR35	8.5"	PSX 12-08 NYLO	12"	12.129"	1.2"	0"
Invert 3										
Invert 4										
Invert 5										
Invert 6										
Invert 7										
Invert 8										

RIGHT-SIDE UP VIEW (int. dimensions)

UPSIDE-DOWN VIEW (int. dimensions)

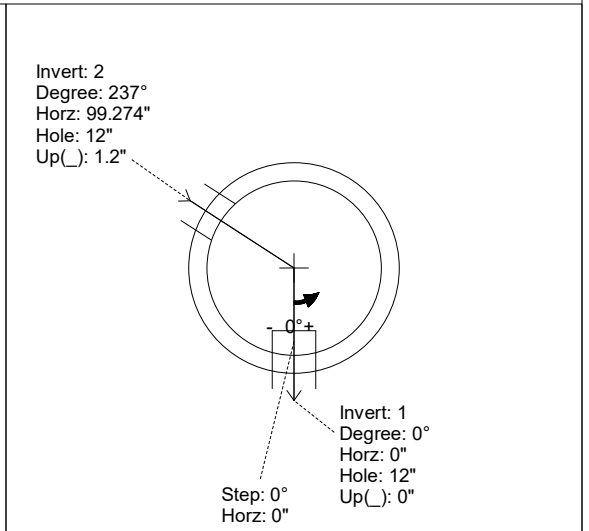
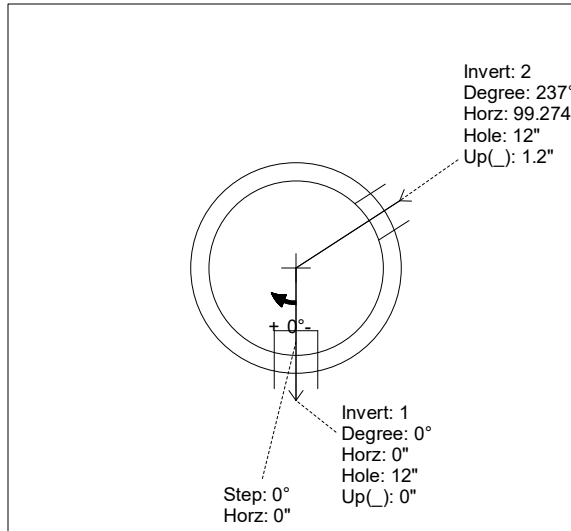
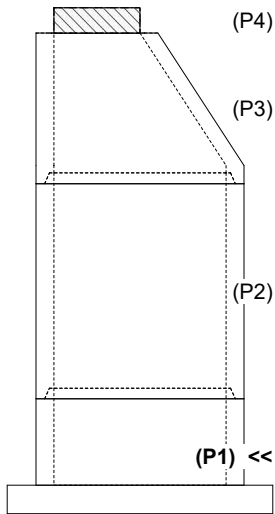

INSIDE WALL DIMENSIONS

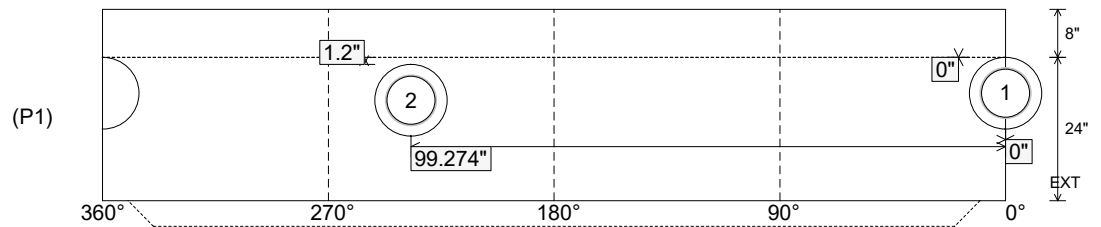

Coating (Int):
 Coating (Ext):

Seam Up: Tongue
 Seam Dn: n/a

Wall Thickness: 5"
 Floor Height: 8"

Height (Int): 24"
 Height (Ext): 32"

Weight (Net): 4468 lb
 Volume (Net): 1.14cu.yd

Job Name: 24-1632 - KYTC Letting Call 100 (241306) Sanitary
 Job Location: Jackson, KY 41339
 Contractor: Triton Construction, Inc.

Plant: Beaver Dam, KY
 1/23/2026 8:01:31 AM

Tech: K. Cardwell
 PC: C. Goff



Structure ID: MH-K105

P1 MH048BAEVfx

MH BASE EF/Xypex Cust. Ht. 08"F (08"EF =74"OD)

P4) 24" - CASTING HEIGHT - 7"	0 lb
P3) 48" - ECC XYPEX CONE w/ 24" HOLE F/G - 42"	3116 lb
P2) 48" - MH RISER w/XYPEX T/G - 60"	4192 lb
P1) 48" - MH BASE EF/Xypex Cust. Ht. 08"F (08"EF =74"OD) T/n - 24"	4468 lb
1) JOINT WRAP PRIMER - CONSEAL CS-75 (1 gal.)	0 lb
1) JOINT WRAP - 0.065"x6"x50' CONSEAL CS212	0 lb
1) 48" - MH INVERT CHANNEL w/XYPEX - FULL HEIGHT	1440 lb
1) ADMIXTURE XYPEX C-500 NF RED	0 lb
1) CASTING - HOE MC-350 F/C Sanitary	305 lb
2) 48" - Conseal CS-102 1.00" (Double)	0 lb
2) PSX - 12-08 NYLO	16 lb
11) MH Step ML-10-TDS-NCR - 10"	0 lb
Structure Total:	13537 lb

Structure Notes:
 STATION: 559+26.31
 1. PER KYTC & ASTM C-478 SPECIFICATIONS
 2. CONCRETE: 5,000 PSI AT 28 DAYS
 3. REINFORCEMENT: PER ASTM A615
 4. INVERT CHANNEL REQUIRED
 5. XYPEX ADMIXTURE REQUIRED
 6. STEPS AT 0 DEGREES
 7. HOE MC-350 FRAME & COVER "SANITARY" SUPPLIED BY ICAST

Rim: 743.03' Rim to Invert: 11.06' Slack: 1.72" Sump: 2" Step Position: 0°

Position	Elev	Angle	Ext. (cw)	Pipe	Pipe OD	Connector	Hole	Horz Size	Up ()	Offset
Invert 1	731.97'	0°	0"	8" PVC SDR35	8.5"	PSX 12-08 NYLO	12"	12.129"	0"	0"
Invert 2	732.07'	237°	119.956"	8" PVC SDR35	8.5"	PSX 12-08 NYLO	12"	12.129"	1.2"	0"
Invert 3										
Invert 4										
Invert 5										
Invert 6										
Invert 7										
Invert 8										

RIGHT-SIDE UP VIEW (int. dimensions)

UPSIDE-DOWN VIEW (int. dimenions)

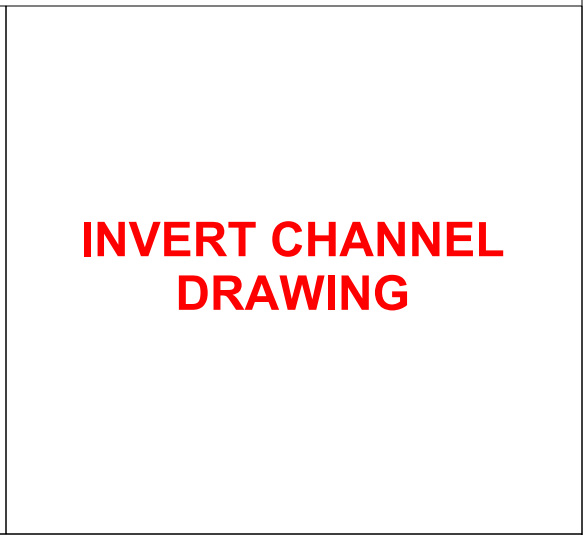
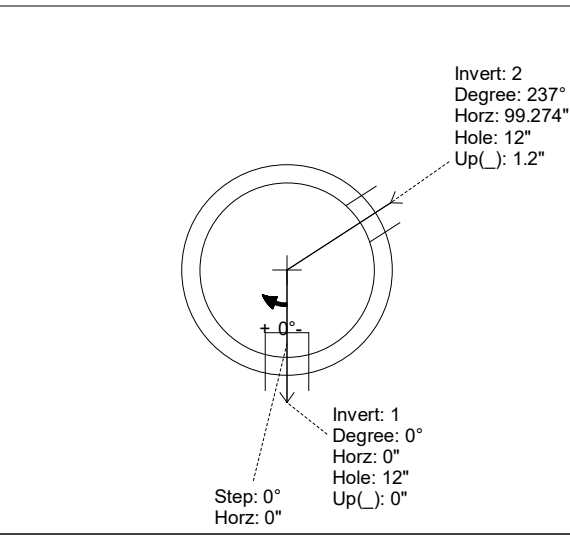
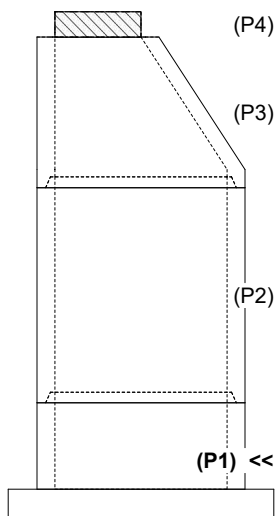

INSIDE WALL DIMENSIONS

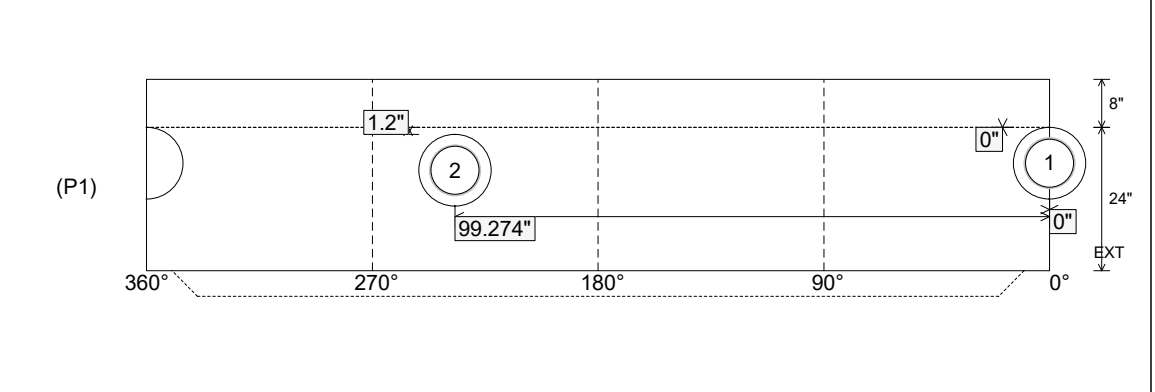

Coating (Int): Coating (Ext):	Seam Up: Tongue Seam Dn: n/a	Wall Thickness: 5" Floor Height: 8"	Height (Int): 24" Height (Ext): 32"	Weight (Net): 4468 lb Volume (Net): 1.14cu.yd
----------------------------------	---------------------------------	--	--	--