

Job Name: 24-1632 - KYTC Letting Call 100 (241306) Sanitary  
 Job Location: Jackson, KY 41339  
 Contractor: Triton Construction, Inc.

Plant: Beaver Dam, KY  
 1/23/2026 8:01:30 AM

Tech: K. Cardwell  
 PC: C. Goff



**Structure ID: MH-K104**

**P1 MH048BAEVfx**

**MH BASE EF/Xypex Cust. Ht. 08"F (08"EF =74"OD)**

P5) 24" - CASTING HEIGHT - 7"	0 lb
P4) 24" - XYPEX GRADE RING F/F - 3"	202 lb
P3) 48" - ECC XYPEX CONE w/ 24" HOLE F/G - 42"	3116 lb
P2) 48" - MH RISER w/XYPEX T/G - 36"	2515 lb
P1) 48" - MH BASE EF/Xypex Cust. Ht. 08"F (08"EF =74"OD) T/n - 18"	4049 lb
1) JOINT WRAP PRIMER - CONSEAL CS-75 (1 gal.)	0 lb
1) JOINT WRAP - 0.065"x6"x50" CONSEAL CS212	0 lb
1) 48" - MH INVERT CHANNEL w/XYPEX - FULL HEIGHT	1440 lb
1) ADMIXTURE XYPEX C-500 NF RED	0 lb
1) CASTING - HOE MC-350 F/C Sanitary	305 lb
2) 48" - Conesal CS-102 1.00" (Double)	0 lb
2) PSX - 12-08 NYLO	16 lb
8) MH Step ML-10-TDS-NCR - 10"	0 lb
<b>Structure Total:</b>	<b>11644 lb</b>

**Structure Notes:**  
 STATION: 560+75.80  
 1. PER KYTC & ASTM C-478 SPECIFICATIONS  
 2. CONCRETE: 5,000 PSI AT 28 DAYS  
 3. REINFORCEMENT: PER ASTM A615  
 4. INVERT CHANNEL REQUIRED  
 5. XYPEX ADMIXTURE REQUIRED  
 6. STEPS AT 0 DEGREES  
 7. HOE MC-350 FRAME & COVER "SANITARY" SUPPLIED BY ICAST

Rim: 739.79' Rim to Invert: 8.72' Slack: 0.64" Sump: 2" Step Position: 0°

Position	Elev	Angle	Ext. (cw)	Pipe	Pipe OD	Connector	Hole	Horz Size	Up ( )	Offset
Invert 1	731.07'	0°	0"	8" PVC SDR35	8.5"	PSX 12-08 NYLO	12"	12.129"	0"	0"
Invert 2	731.17'	182°	92.118"	8" PVC SDR35	8.5"	PSX 12-08 NYLO	12"	12.129"	1.2"	0"
Invert 3										
Invert 4										
Invert 5										
Invert 6										
Invert 7										
Invert 8										

RIGHT-SIDE UP VIEW (int. dimensions)

UPSIDE-DOWN VIEW (int. dimensions)

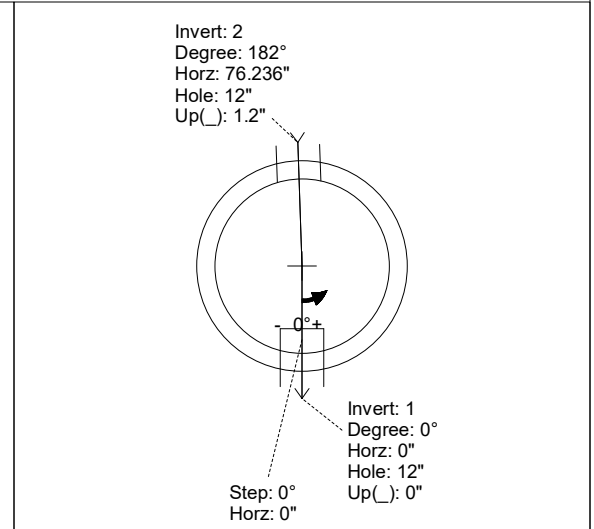
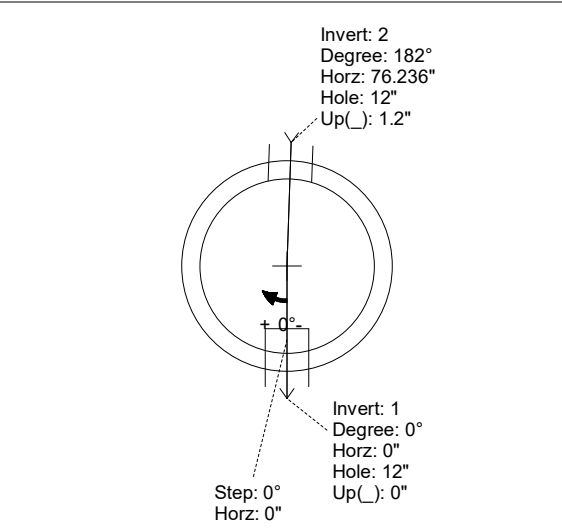
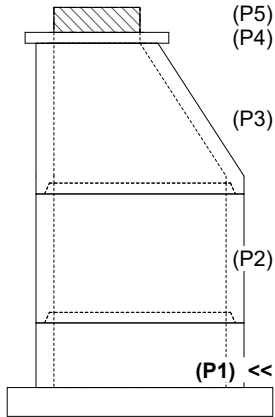

INSIDE WALL DIMENSIONS

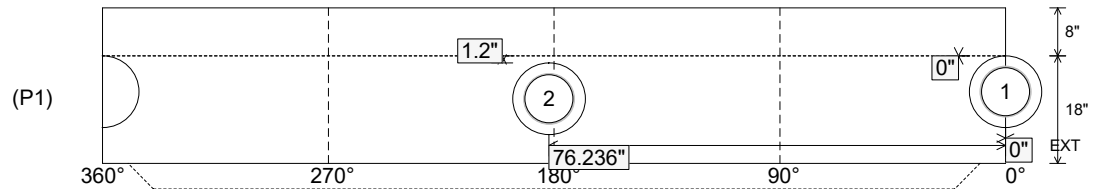

Coating (Int):  
 Coating (Ext):

Seam Up: Tongue  
 Seam Dn: n/a

Wall Thickness: 5"  
 Floor Height: 8"

Height (Int): 18"  
 Height (Ext): 26"

Weight (Net): 4049 lb  
 Volume (Net): 1.03cu.yd

Job Name: 24-1632 - KYTC Letting Call 100 (241306) Sanitary  
 Job Location: Jackson, KY 41339  
 Contractor: Triton Construction, Inc.

Plant: Beaver Dam, KY  
 1/23/2026 8:01:30 AM

Tech: K. Cardwell  
 PC: C. Goff



**Structure ID: MH-K104**

**P1 MH048BAEVfx**

**MH BASE EF/Xypex Cust. Ht. 08"F (08"EF =74"OD)**

P5) 24" - CASTING HEIGHT - 7"	0 lb
P4) 24" - XYPEX GRADE RING F/F - 3"	202 lb
P3) 48" - ECC XYPEX CONE w/ 24" HOLE F/G - 42"	3116 lb
P2) 48" - MH RISER w/XYPEX T/G - 36"	2515 lb
P1) 48" - MH BASE EF/Xypex Cust. Ht. 08"F (08"EF =74"OD) T/n - 18"	4049 lb
1) JOINT WRAP PRIMER - CONSEAL CS-75 (1 gal.)	0 lb
1) JOINT WRAP - 0.065"x6"x50" CONSEAL CS212	0 lb
1) 48" - MH INVERT CHANNEL w/XYPEX - FULL HEIGHT	1440 lb
1) ADMIXTURE XYPEX C-500 NF RED	0 lb
1) CASTING - HOE MC-350 F/C Sanitary	305 lb
2) 48" - Conesal CS-102 1.00" (Double)	0 lb
2) PSX - 12-08 NYLO	16 lb
8) MH Step ML-10-TDS-NCR - 10"	0 lb
<b>Structure Total:</b>	<b>11644 lb</b>

**Structure Notes:**  
 STATION: 560+75.80  
 1. PER KYTC & ASTM C-478 SPECIFICATIONS  
 2. CONCRETE: 5,000 PSI AT 28 DAYS  
 3. REINFORCEMENT: PER ASTM A615  
 4. INVERT CHANNEL REQUIRED  
 5. XYPEX ADMIXTURE REQUIRED  
 6. STEPS AT 0 DEGREES  
 7. HOE MC-350 FRAME & COVER "SANITARY" SUPPLIED BY ICAST

Rim: 739.79' Rim to Invert: 8.72' Slack: 0.64" Sump: 2" Step Position: 0°

Position	Elev	Angle	Ext. (cw)	Pipe	Pipe OD	Connector	Hole	Horz Size	Up ( )	Offset
Invert 1	731.07'	0°	0"	8" PVC SDR35	8.5"	PSX 12-08 NYLO	12"	12.129"	0"	0"
Invert 2	731.17'	182°	92.118"	8" PVC SDR35	8.5"	PSX 12-08 NYLO	12"	12.129"	1.2"	0"
Invert 3										
Invert 4										
Invert 5										
Invert 6										
Invert 7										
Invert 8										

**RIGHT-SIDE UP VIEW (int. dimensions) UPSIDE-DOWN VIEW (int. dimenions)**

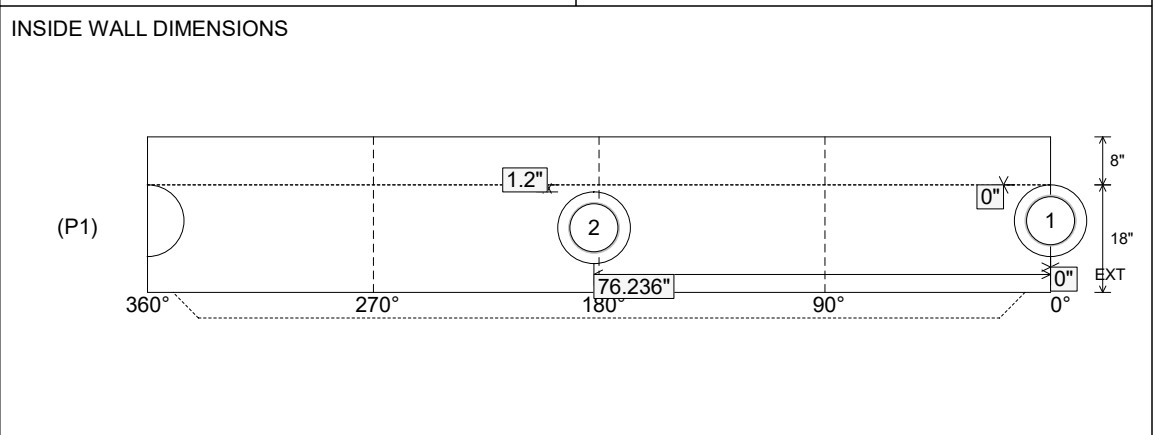
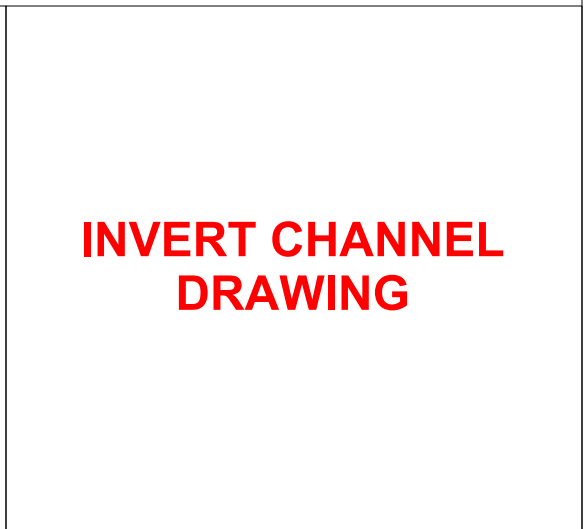
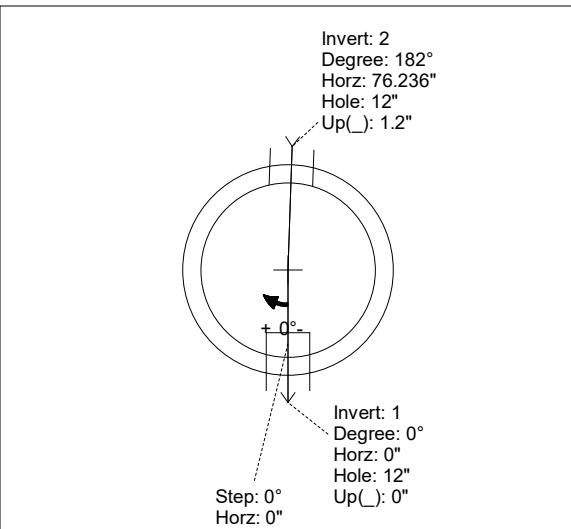
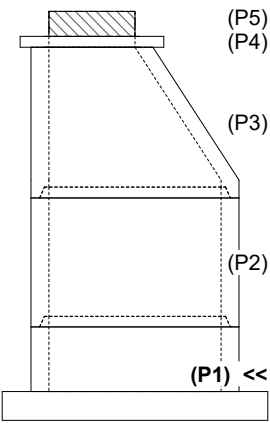

Coating (Int): Coating (Ext):	Seam Up: Tongue Seam Dn: n/a	Wall Thickness: 5" Floor Height: 8"	Height (Int): 18" Height (Ext): 26"	Weight (Net): 4049 lb Volume (Net): 1.03cu.yd
----------------------------------	---------------------------------	--	--	--