

Job Name: 24-1260 - Combined Sewer Separation Project Phase 3
 Job Location: Morganfield, KY 42437
 Contractor: Deig Bros Lumber & Construction Co, Inc.

Plant: Beaver Dam, KY
 10/7/2025 9:04:00 AM

Tech: K. Cardwell
 PC: A. Chambers



Structure ID: STMH 9+62

P1 MH060BAEVF

MH BASE w/FLANGE (08F/07EF) T/n

- P4) 24" - CASTING HEIGHT - 8"
- P3) 60" - MH FLAT LID w/24in ECC Hole F/G - 13"
- P2) 60" - MH RISER SPECIAL T/G - 54"
- P1) 60" - MH BASE w/FLANGE (08F/07EF) T/n - 54"
- 1) 60" - EXT. FLG (60ø MH)7"WD/8"THK
- 1) CASTING - HOE KY-510 F/C (KY TY.2)
- 2) 60" - Conseal CS-102 1.00"
- 2) Hole - 48
- 2) Hole - 18
- 9) MH Step ML-10-TDS-NCR - 10"

0 lb
 2800 lb
 5507 lb
 6186 lb
 1167 lb
 510 lb
 0 lb
 0 lb
 0 lb
 0 lb
 0 lb
 16170 lb

Structure Notes:
 STATION: 9+62 STORM LN A
 1. PER KYTC MH B / ASTM C-478 SPECS
 2. CONCRETE: 5,000 PSI AT 28 DAYS
 3. REINFORCEMENT: PER ASTM A615
 4. STORM INVERT BY OTHERS
 5. STEPS AT 245 DEGREES
 6. KY-510 FRAME & COVER SUPPLIED BY ICAST
 7. INVERT 4 OFFSET 3" FROM CENTER

Structure Total: 16170 lb

FIRST POUR (BASE): 6,186 LBS
SECOND POUR (EXT. FLANGE): 1,167 LBS

Rim: 424.41' Rim to Invert: 10.45' Slack: 2.4" Sump: 0" Step Position: 245

Position	Elev	Angle	Ext. (cw)	Pipe	Pipe OD	Connector	Hole	Horz Size	Up ()	Offset
Invert 1	413.96'	0°	0"	36" RCP B WALL	44"	Hole 48	48"	55.638"	0"	0"
Invert 2										
Invert 3	413.96'	168°	105.558"	36" RCP B WALL	44"	Hole 48	48"	55.638"	0"	0"
Invert 4	416.44'	295°	182.35"	12" HDPE	14.5"	Hole 18	18"	18.386"	32.76"	-3"
Invert 5										
Invert 6										
Invert 7										
Invert 8										

RIGHT-SIDE UP VIEW (int. dimensions)

UPSIDE-DOWN VIEW (int. dimensions)

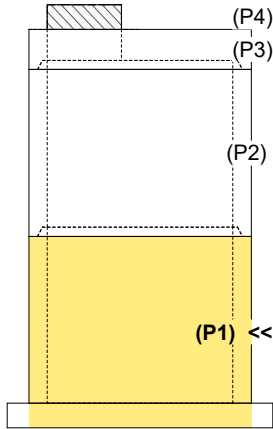
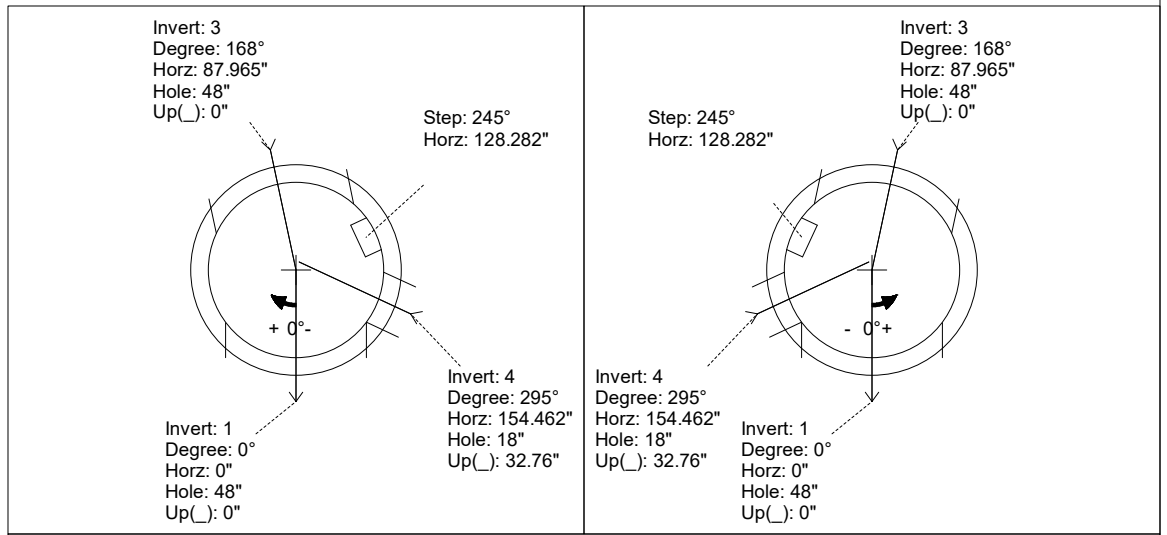

INSIDE WALL DIMENSIONS

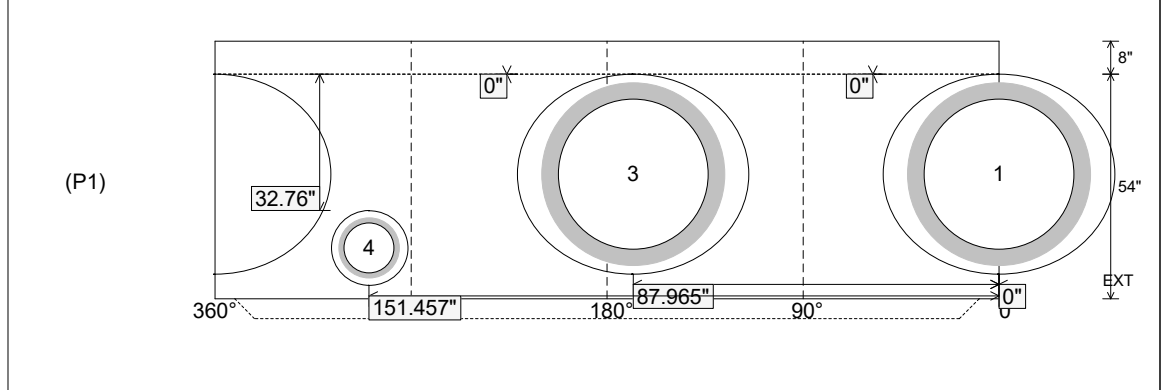

Coating (Int):
 Coating (Ext):

Seam Up: Tongue
 Seam Dn: n/a

Wall Thickness: 6"
 Floor Height: 8"

Height (Int): 54"
 Height (Ext): 62"

Weight (Net): 7353 lb
 Volume (Net): 1.88cu.yd

Job Name: 24-1260 - Combined Sewer Separation Project Phase 3
 Job Location: Morganfield, KY 42437
 Contractor: Deig Bros Lumber & Construction Co, Inc.

Plant: Beaver Dam, KY
 10/7/2025 9:04:00 AM

Tech: K. Cardwell
 PC: A. Chambers



Structure ID: STMH 9+62

P1 MH060EXBAP

7" EXTENDED FLANGE POUR

- P4) 24" - CASTING HEIGHT - 8"
- P3) 60" - MH FLAT LID w/24in ECC Hole F/G - 13"
- P2) 60" - MH RISER SPECIAL T/G - 54"
- P1) 60" - MH BASE w/FLANGE (08F/07EF) T/n - 54"
- 1) 60" - EXT. FLG (60ø MH)7"WD/8"THK
- 1) CASTING - HOE KY-510 F/C (KY TY.2)
- 2) 60" - Conseal CS-102 1.00"
- 2) Hole - 48
- 2) Hole - 18
- 9) MH Step ML-10-TDS-NCR - 10"

0 lb
 2800 lb
 5507 lb
 6186 lb
 1167 lb
 510 lb
 0 lb
 0 lb
 0 lb
 0 lb
 Structure Total: 16170 lb

- Structure Notes:**
 STATION: 9+62 STORM LN A
1. PER KYTC MH B / ASTM C-478 SPECS
 2. CONCRETE: 5,000 PSI AT 28 DAYS
 3. REINFORCEMENT: DRILL & DOWEL #5 BAR @ 8" C.C. E.W. (GRADE 60) FOR FLANGE POUR TIE-IN - MIN. 4" PENETRATION INTO BASE FLOOR & 2" MIN. REBAR CLEARANCE (TYP)
 4. STORM INVERT BY OTHERS
 5. STEPS AT 245 DEGREES
 6. KY-510 FRAME & COVER SUPPLIED BY ICAST
 7. INVERT 4 OFFSET 3" FROM CENTER

FIRST POUR (BASE): 6,186 LBS
SECOND POUR (EXT. FLANGE): 1,167 LBS

Rim: 424.41' Rim to Invert: 10.45' Slack: 2.4" Sump: 0" Step Position: 245

Position	Elev	Angle	Ext. (cw)	Pipe	Pipe OD	Connector	Hole	Horz Size	Up ()	Offset
Invert 1	413.96'	0°	0"	36" RCP B WALL	44"	Hole 48	48"	55.638"	0"	0"
Invert 2										
Invert 3	413.96'	168°	105.558"	36" RCP B WALL	44"	Hole 48	48"	55.638"	0"	0"
Invert 4	416.44'	295°	182.35"	12" HDPE	14.5"	Hole 18	18"	18.386"	32.76"	-3"
Invert 5										
Invert 6										
Invert 7										
Invert 8										

RIGHT-SIDE UP VIEW (int. dimensions)

UPSIDE-DOWN VIEW (int. dimensions)

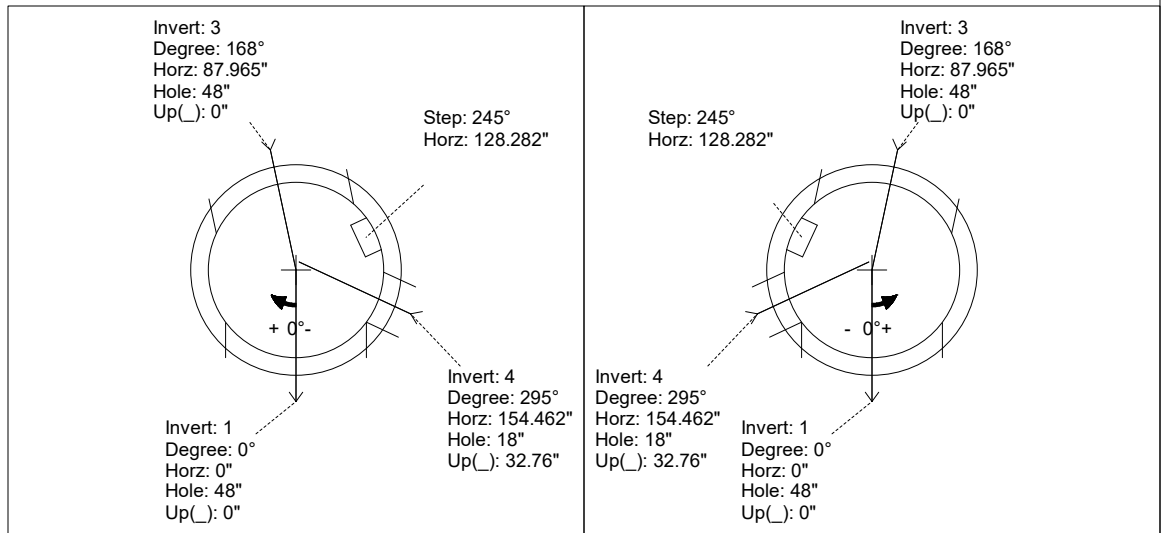

INSIDE WALL DIMENSIONS

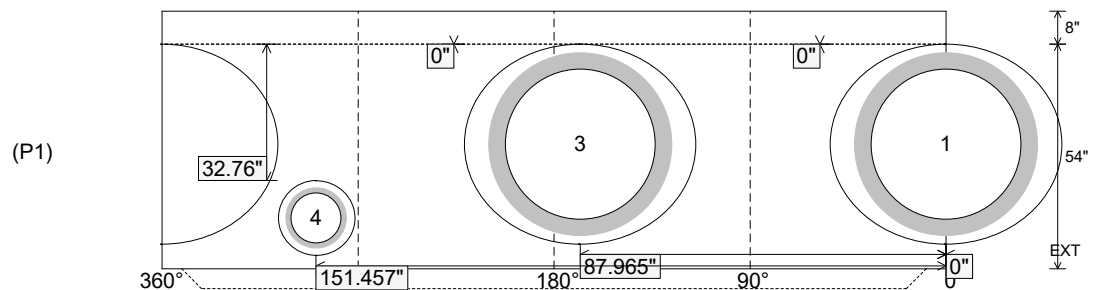

DRILL & DOWEL #5 BAR @ 8" C.C. E.W. (GRADE 60) FOR FLANGE POUR TIE-IN - MIN. 4" PENETRATION INTO BASE FLOOR & 2" MIN. REBAR CLEARANCE (TYP)

Coating (Int):
 Coating (Ext):

Seam Up: Tongue
 Seam Dn: n/a

Wall Thickness: 6"
 Floor Height: 8"

Height (Int): 54"
 Height (Ext): 62"

Weight (Net): 7353 lb
 Volume (Net): 1.88cu.yd