

Job Name: 24-1260 - Combined Sewer Separation Project Ph 3  
 Job Location: Morganfield, KY 42437  
 Contractor: Deig Bros Lumber & Construction Co, Inc.

Plant: Beaver Dam, KY

Tech: K. Cardwell

12/18/2025 9:47:49 AM

PC: J. Jarvis



**Structure ID: SSMH 3+65**

**P2 MH048CN42**

**ECC CONE w/ 24" HOLE F/G**

- P4) 24" - CASTING HEIGHT - 7"
- P3) 24" - GRADE RING F/F - 4"
- P2) 48" - ECC CONE w/ 24" HOLE F/G - 42"
- P1) 48" - MH BASE T/n - 36"
- 1) JOINT WRAP - 0.065"x6"x50" CONSEAL CS212
- 1) JOINT WRAP PRIMER - CONSEAL CS-75 (1 gal.)
- 1) 48" - MH INVERT CHANNEL - FULL HEIGHT
- 1) Chimney Seal - Trelleborg FlexRib Chimney Seal
- 1) CASTING - HOE MC-420 F/C Sanitary
- 1) 48" - Conseal CS-102 1.00" (Double)
- 2) PSX - 12-08 NYLO
- 6) MH Step ML-10-TDS-NCR - 10"

- 0 lb
- 270 lb
- 3200 lb
- 3749 lb
- 0 lb
- 0 lb
- 1440 lb
- 10 lb
- 340 lb
- 0 lb
- 16 lb
- 0 lb

Structure Notes:  
 STATION: 3+65 SAN LN F  
 1. PER ASTM C-478 SPECS  
 2. CONCRETE: 5,000 PSI AT 28 DAYS  
 3. REINFORCEMENT: PER ASTM A615  
 4. INVERT CHANNEL REQUIRED  
 5. HOE MC-420 "SANITARY" SUPPLIED BY ICAST  
 6. STEPS AT 0 DEGREES  
 7. TRELLEBORG FLEXRIB 8.5" CHIMNEY SEAL SUPPLIED BY ICAST

Structure Total: 9025 lb

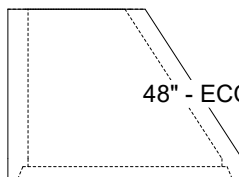
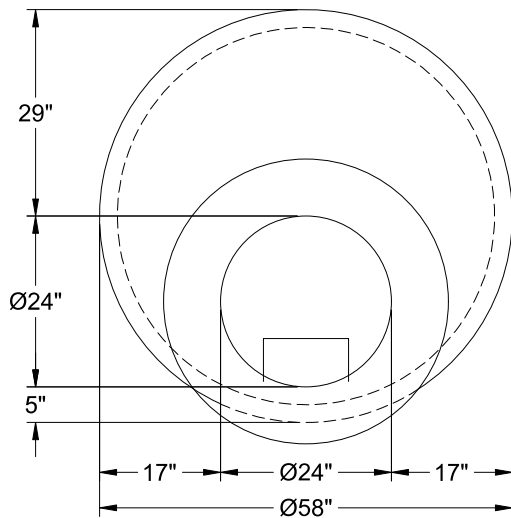

48" - ECC CONE w/ 24" HOLE F/G - 42" - (P2)

Coating (Int):  
 Coating (Ext):

Seam Up: Flat  
 Seam Dn: Groove

Wall Thickness: 5"

Height (Ext): 42"

Weight (Net): 3200 lb  
 Volume (Net): 0.5cu.yd