

Job Name: 24-1260 - Combined Sewer Separation Project Ph 3
 Job Location: Morganfield, KY 42437
 Contractor: Deig Bros Lumber & Construction Co, Inc.

Plant: Beaver Dam, KY

Tech: K. Cardwell

12/18/2025 9:47:49 AM

PC: J. Jarvis



Structure ID: SSMH 2+48

P2 MH048CN42

ECC CONE w/ 24" HOLE F/G

- P4) 24" - CASTING HEIGHT - 7"
- P3) 24" - GRADE RING F/F - 3"
- P2) 48" - ECC CONE w/ 24" HOLE F/G - 42"
- P1) 48" - MH BASE T/n - 30"
- 1) JOINT WRAP - 0.065"x6"x50' CONSEAL CS212
- 1) JOINT WRAP PRIMER - CONSEAL CS-75 (1 gal.)
- 1) 48" - MH INVERT CHANNEL - FULL HEIGHT
- 1) Chimney Seal - Trelleborg FlexRib Chimney Seal
- 1) CASTING - HOE MC-420 F/C Sanitary
- 1) 48" - Conseal CS-102 1.00" (Double)
- 2) PSX - 12-08 NYLO
- 1) PSX - 16Y NYLO
- 6) MH Step ML-10-TDS-NCR - 10"

- 0 lb
- 202 lb
- 3200 lb
- 3244 lb
- 0 lb
- 0 lb
- 1440 lb
- 10 lb
- 340 lb
- 0 lb
- 16 lb
- 8 lb
- 0 lb

Structure Notes:
 STATION: 2+48 SAN LN F
 1. PER ASTM C-478 SPECS
 2. CONCRETE: 5,000 PSI AT 28 DAYS
 3. REINFORCEMENT: PER ASTM A615
 4. INVERT CHANNEL REQUIRED
 5. HOE MC-420 "SANITARY" SUPPLIED BY ICAST
 6. STEPS AT 0 DEGREES
 7. TRELLEBORG FLEXRIB 8.5" CHIMNEY SEAL SUPPLIED BY ICAST

Structure Total: 8461 lb

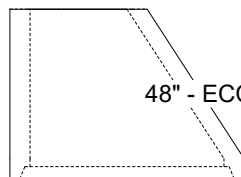
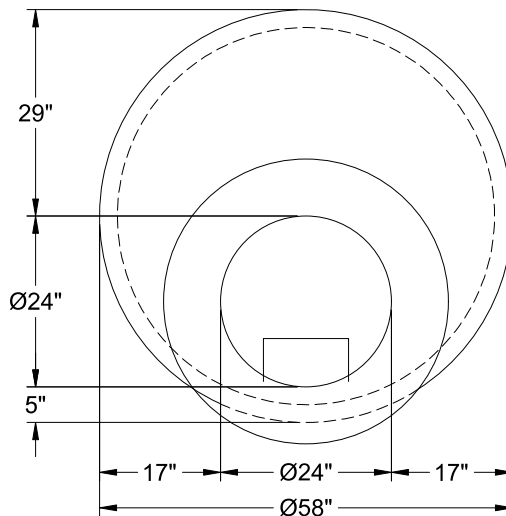

48" - ECC CONE w/ 24" HOLE F/G - 42" - (P2)

Coating (Int):
 Coating (Ext):

Seam Up: Flat
 Seam Dn: Groove

Wall Thickness: 5"

Height (Ext): 42"

Weight (Net): 3200 lb
 Volume (Net): 0.5cu.yd