

Job Name: 24-1260 - Combined Sewer Separation Project Ph 3  
 Job Location: Morganfield, KY 42437  
 Contractor: Deig Bros Lumber & Construction Co, Inc.

Plant: Beaver Dam, KY  
 11/13/2025 2:20:08 PM

Tech: K. Cardwell  
 PC: J. Jarvis



**Structure ID: SSMH 2+01B**

**P3 MH048LD12ECC**

**MH FLAT TOP w/ 24" ECC Hole F/G**

- P4) 24" - CASTING HEIGHT - 7"
- P3) 48" - MH FLAT TOP w/ 24" ECC Hole F/G - 12"
- P2) 48" - MH RISER Custom Ht T/G - 49"
- P1) 48" - MH BASE T/n - 24"
- 1) JOINT WRAP - 0.065"x6"x50' CONSEAL CS212
- 1) JOINT WRAP PRIMER - CONSEAL CS-75 (1 gal.)
- 1) 48" - MH INVERT CHANNEL - FULL HEIGHT
- 1) Chimney Seal - Trelleborg FlexRib Chimney Seal
- 1) CASTING - HOE MC-420 F/C Sanitary
- 2) 48" - Conseal CS-102 1.00" (Double)
- 2) PSX - 12-08 NYLO
- 1) Kor-N-Seal1 - S406-10AW
- 1) PSX - 12-06 NYLO
- 5) MH Step ML-10-TDS-NCR - 10"

- |                                                                                                                                                                                                                                                                                              |                                                                                                                                                                                                                                                                                                                                                                                                                                                                                                                                                                          |
|----------------------------------------------------------------------------------------------------------------------------------------------------------------------------------------------------------------------------------------------------------------------------------------------|--------------------------------------------------------------------------------------------------------------------------------------------------------------------------------------------------------------------------------------------------------------------------------------------------------------------------------------------------------------------------------------------------------------------------------------------------------------------------------------------------------------------------------------------------------------------------|
| <ul style="list-style-type: none"> <li>0 lb</li> <li>1561 lb</li> <li>3342 lb</li> <li>2911 lb</li> <li>0 lb</li> <li>0 lb</li> <li>1440 lb</li> <li>10 lb</li> <li>340 lb</li> <li>0 lb</li> <li>16 lb</li> <li>6 lb</li> <li>8 lb</li> <li>0 lb</li> <li>-----</li> <li>9635 lb</li> </ul> | <p><b>Structure Notes:</b><br/>         STATION: 2+01B SAN LN D</p> <ol style="list-style-type: none"> <li>1. PER ASTM C-478 SPECS</li> <li>2. CONCRETE: 5,000 PSI AT 28 DAYS</li> <li>3. REINFORCEMENT: #4 BAR @ 10" C.C. E.W. (GRADE 60) - 2" MIN. REBAR CLEARANCE (TYP)</li> <li>4. INVERT CHANNEL REQUIRED</li> <li>5. HOE MC-420 "SANITARY" SUPPLIED BY ICAST</li> <li>6. STEPS AT 0 DEGREES</li> <li>7. TRELLEBORG FLEXRIB 8.5" CHIMNEY SEAL SUPPLIED BY ICAST</li> <li>8. LIFTERS: 3 EA. WRA016 CONAC WIRE ROPE ANCHORS FOR PLANT &amp; FIELD HANDLING</li> </ol> |
|----------------------------------------------------------------------------------------------------------------------------------------------------------------------------------------------------------------------------------------------------------------------------------------------|--------------------------------------------------------------------------------------------------------------------------------------------------------------------------------------------------------------------------------------------------------------------------------------------------------------------------------------------------------------------------------------------------------------------------------------------------------------------------------------------------------------------------------------------------------------------------|

Structure Total: 9635 lb

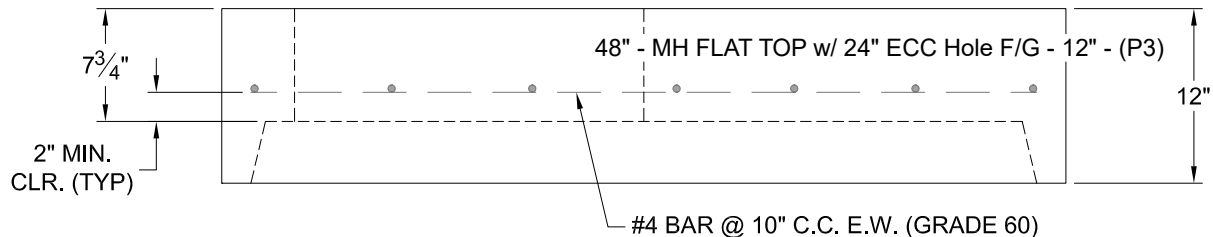
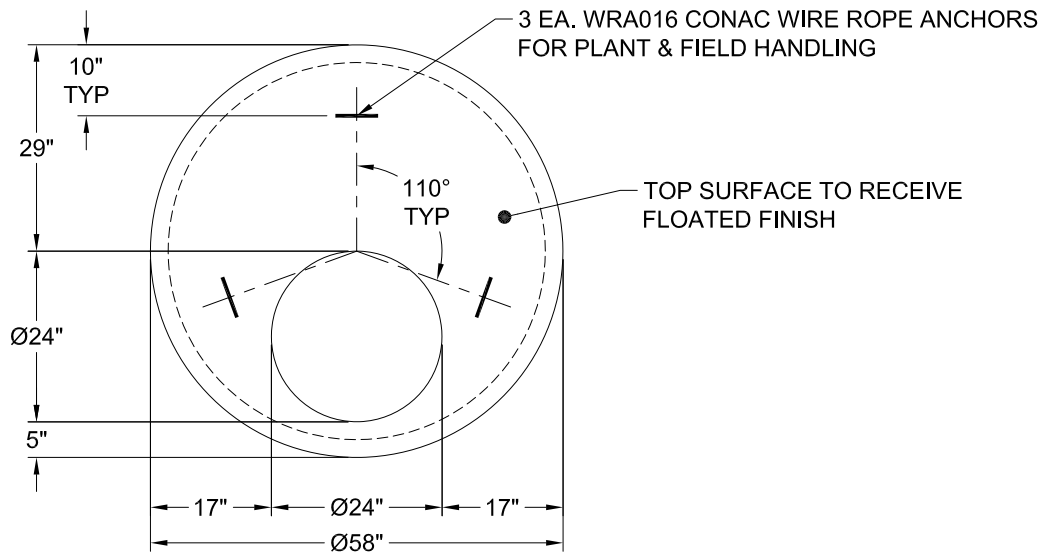

Coating (Int): Coating (Ext):	Seam Up: Flat Seam Dn: Groove	Wall Thickness: 5"	Height (Ext): 12"	Weight (Net): 1561 lb Volume (Net): 0.42cu.yd
----------------------------------	----------------------------------	--------------------	-------------------	--------------------------------------------------