

Job Name: 24-1260 - Combined Sewer Separation Project Ph 3  
 Job Location: Morganfield, KY 42437  
 Contractor: Deig Bros Lumber & Construction Co, Inc.

Plant: Beaver Dam, KY  
 11/13/2025 2:20:00 PM

Tech: K. Cardwell  
 PC: J. Jarvis



**Structure ID: SSMH 12+25**

**P3 MH048CN30**

**ECC CONE w/ 24" HOLE F/G**

- P5) 24" - CASTING HEIGHT - 7"
- P4) 24" - GRADE RING F/F - 4"
- P3) 48" - ECC CONE w/ 24" HOLE F/G - 30"
- P2) 48" - MH RISER T/G - 48"
- P1) 48" - MH BASE T/n - 24"
- 1) JOINT WRAP - 0.065"x6"x50' CONSEAL CS212
- 1) JOINT WRAP PRIMER - CONSEAL CS-75 (1 gal.)
- 1) 48" - MH INVERT CHANNEL - FULL HEIGHT
- 1) Chimney Seal - Trelleborg FlexRib Chimney Seal
- 1) CASTING - HOE MC-420 F/C Sanitary
- 2) 48" - Conseal CS-102 1.00" (Double)
- 2) PSX - 16Y NYLO
- 2) PSX - 12-06 NYLO
- 8) MH Step ML-10-TDS-NCR - 10"

0 lb  
 270 lb  
 2050 lb  
 3353 lb  
 2738 lb  
 0 lb  
 0 lb  
 1440 lb  
 10 lb  
 340 lb  
 0 lb  
 16 lb  
 16 lb  
 0 lb

**Structure Notes:**  
 STATION: 12+25 SAN LN A  
 1. PER ASTM C-478 SPECS  
 2. CONCRETE: 5,000 PSI AT 28 DAYS  
 3. REINFORCEMENT: PER ASTM A615  
 4. INVERT CHANNEL REQUIRED  
 5. HOE MC-420 "SANITARY" SUPPLIED BY ICAST  
 6. STEPS AT 0 DEGREES  
 7. TRELLEBORG FLEXRIB 8.5" CHIMNEY SEAL SUPPLIED BY ICAST

Structure Total: 10233 lb

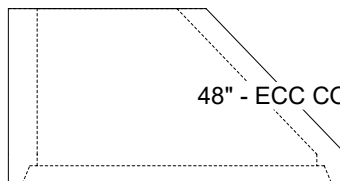
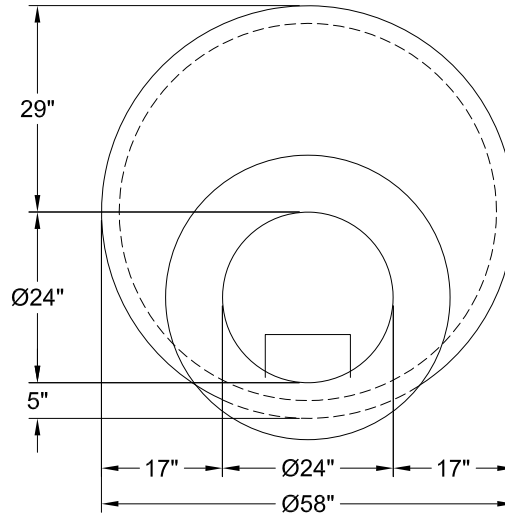

48" - ECC CONE w/ 24" HOLE F/G - 30" - (P3)

Coating (Int):  
 Coating (Ext):

Seam Up: Flat  
 Seam Dn: Groove

Wall Thickness: 5"

Height (Ext): 30"

Weight (Net): 2050 lb  
 Volume (Net): 0.41cu.yd