

Job Name: 24-1260 - Combined Sewer Separation Project Phase 3
 Job Location: Morganfield, KY 42437
 Contractor: Deig Bros Lumber & Construction Co, Inc.

Plant: Beaver Dam, KY

Tech: K. Cardwell

10/7/2025 9:04:04 AM

PC: A. Chambers



Structure ID: CB 25

P1 BX24300808VF

BOX BASE 8inW, 8inF, Variable Ht T/n

- P3) 24" x 30" - CASTING HEIGHT - 4"
- P2) 24" x 30" - BOX RISER 8inW F/G - 24"
- P1) 24" x 30" - BOX BASE 8inW, 8inF, Variable Ht T/n - 29"
- 1) CASTING - HOE KY-460-11 F/G (DBI 11)
- 2) 24" x 30" - Conseal CS-102 1.00"
- 1) Hole - 18

0 lb
 2256 lb
 3772 lb
 421 lb
 0 lb
 0 lb

 Structure Total: 6449 lb

Structure Notes:
 STATION: 12+40 STORM LN A
 1. KYTC DBI TYPE 11 / ASTM C-913 SPECS
 2. CONCRETE: 5,000 PSI AT 28 DAYS
 3. REINFORCEMENT: #5 BAR @ 12" C.C. E.W. (GRADE 60) - 2" MIN. REBAR CLEARANCE (TYP)
 4. KY-460 FRAME & GRATE SUPPLIED BY ICAST

Rim: 425' Rim to Invert: 5' Slack: 3" Sump: 0" Step Position:

Position	Elev	Angle	Ext. (cw)	Pipe	Pipe OD	Connector	Hole	Horz Size	Up ()	Offset
Invert 1	420'	115°	25.706"	12" ADS N-12	14.5"	Hole 18	18"	19.861"	-3"	-6"
Invert 2										
Invert 3										
Invert 4										
Invert 5										
Invert 6										
Invert 7										
Invert 8										

RIGHT-SIDE UP VIEW (int. dimensions)

UPSIDE-DOWN VIEW (int. dimensions)

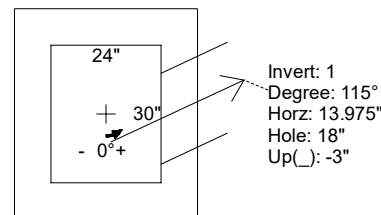
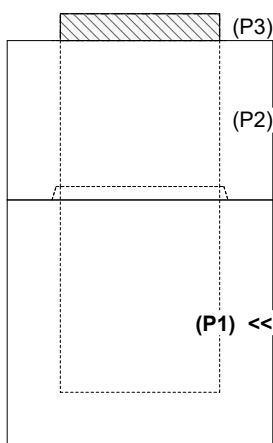

INSIDE WALL DIMENSIONS

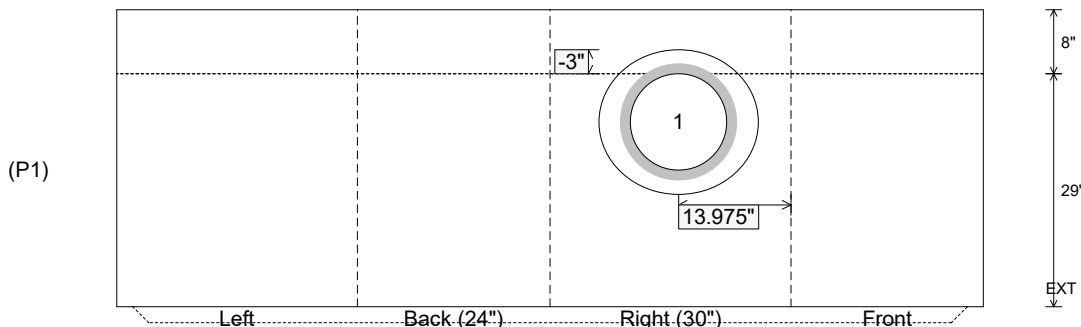

Coating (Int):
 Coating (Ext):

Seam Up: Tongue
 Seam Dn: n/a

Wall Thickness: 8"
 Floor Height: 8"

Height (Int): 29"
 Height (Ext): 37"

Weight (Net): 3772 lb
 Volume (Net): 0.96cu.yd