

Job Name: 23-2792 - Teal Dr. Development  
 Job Location: Gallatin, TN  
 Contractor: Stewart Richey

Plant: 100  
 3/25/2026 1:41:43 PM

Tech: J. Horsley - F  
 PC: C. Goff



**Structure ID: STM-E5**

**P1 BX2828-06BA42**

**BOX BASE 6inW, 6inF F/n**

- P2) 28" x 28" - CASTING HEIGHT - 6"
- P1) 28" x 28" - BOX BASE 6inW, 6inF F/n - 42"
- 1) CASTING - JBS 3101 Single Set (F/G/H)
- 1) 28" x 28" - Conseal CS-102 1.00"
- 2) Hole - 22

0 lb  
 3299 lb  
 619 lb  
 0 lb  
 0 lb  
 -----  
 0 lb  
 Structure Total: 3918 lb

**Structure Notes:**  
 1. PER ASTM C913 SPECIFICATIONS.  
 2. CONCRETE = 4,000 PSI AT 28 DAYS.  
 3. NO STEPS AND NO INVERT CHANNEL.  
 4. CASTING BY ICAST (JBS 3101 SINGLE SET (F/G/H)).

REINFORCING PER ASTM A615 (GRADE 60).  
 - WALLS (As .31) #5 BARS AT 12" C.C.E.W.  
 - FLOOR (As .31) #5 BARS AT 12" C.C.E.W.

Rim: 472.54' Rim to Invert: 4.02' Slack: 0.24" Sump: 0" Step Position:

Position	Elev	Angle	Ext. (cw)	Pipe	Pipe OD	Connector	Hole	Horz Size	Up ( )	Offset
Invert 1	468.52'	0°	20"	15" RCP B WALL	19.5"	Hole 22	22"	22"	-2.25"	0"
Invert 2	468.52'	180°	20"	15" RCP B WALL	19.5"	Hole 22	22"	22"	-2.25"	0"
Invert 3										
Invert 4										
Invert 5										
Invert 6										
Invert 7										
Invert 8										

RIGHT-SIDE UP VIEW (int. dimensions)

UPSIDE-DOWN VIEW (int. dimensions)

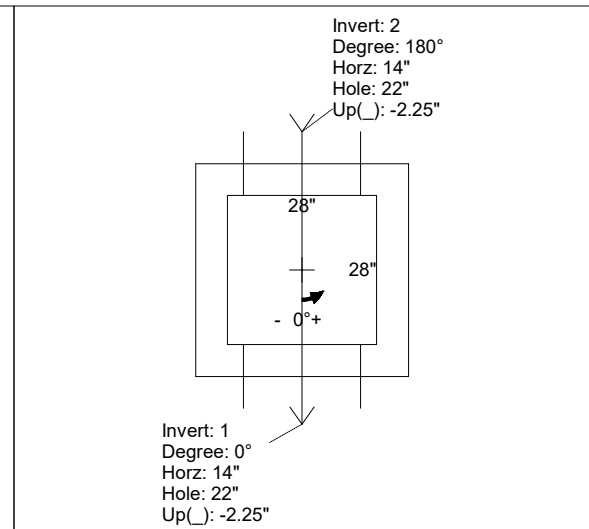
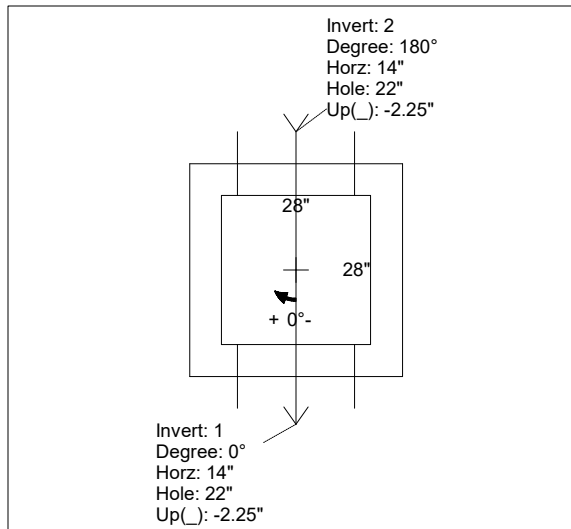
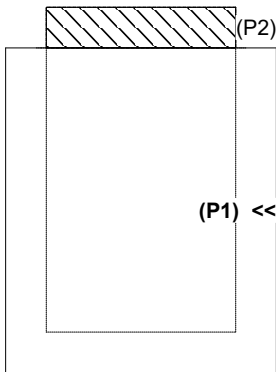

INSIDE WALL DIMENSIONS

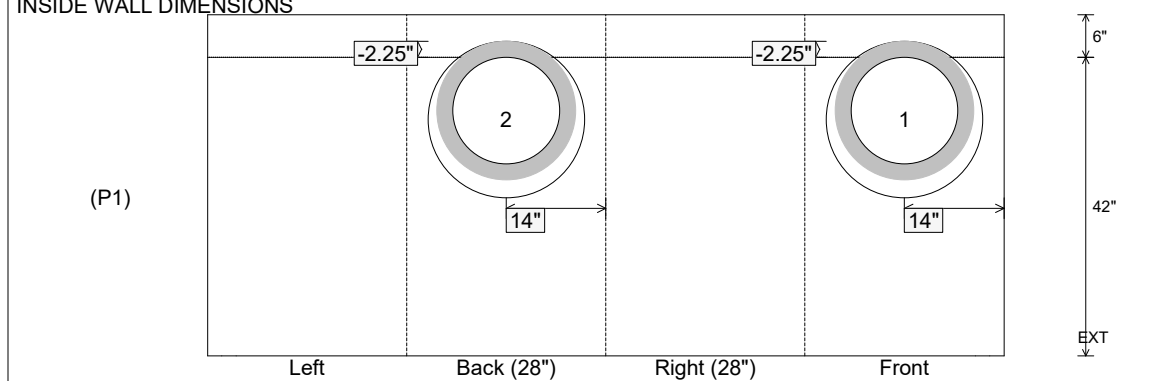

Coating (Int):  
 Coating (Ext):

Seam Up: Flat  
 Seam Dn: n/a

Wall Thickness: 6"  
 Floor Height: 6"

Height (Int): 42"  
 Height (Ext): 48"

Weight (Net): 3299 lb  
 Volume (Net): 0.84cu.yd