

Job Name: 23-2792 - Teal Dr. Development  
 Job Location: Gallatin, TN  
 Contractor: Stewart Richey

Plant: 100  
 3/25/2026 1:41:41 PM

Tech: J. Horsley - F  
 PC: C. Goff



**Structure ID: STM-E3**

**P1 MH048BA48**

**MH BASE T/n**

- P3) 30" x 30" - CASTING HEIGHT - 6"
- P2) 48" - MH FLAT TOP w/30"x30" Hole F/G - 12"
- P1) 48" - MH BASE T/n - 48"
- 1) CASTING - JBS 3101 Single Set (F/G/H)
- 1) 48" - Conseal CS-102 1.00"
- 1) 30" x 30" - Conseal CS-102 1.00"
- 2) Hole - 22
- 4) MH Step ML-10-TDS-NCR - 10"

0 lb  
 1350 lb  
 4354 lb  
 619 lb  
 0 lb  
 0 lb  
 0 lb  
 0 lb  
 0 lb  
 Structure Total: 6323 lb

**Structure Notes:**  
 1. PER ASTM C478 SPECIFICATIONS.  
 2. CONCRETE = 4,000 PSI AT 28 DAYS.  
 3. NO INVERT CHANNEL.  
 4. CASTING BY ICAST (JBS 3101 SINGLE SET (F/G/H))

REINFORCING PER ASTM A615 (GRADE 60).  
 - TOP SLAB (As .62) #5 BARS AT 6" C.C.E.W..  
 - RISER/WALLS (As .12)  
 - FLOOR (As .31) #5 BARS AT 12" C.C.E.W.

Rim: 473.07' Rim to Invert: 5.55' Slack: 0.6" Sump: 0" Step Position: 130°

| Position | Elev    | Angle | Ext. (cw) | Pipe           | Pipe OD | Connector | Hole | Horz Size | Up ( ) | Offset |
|----------|---------|-------|-----------|----------------|---------|-----------|------|-----------|--------|--------|
| Invert 1 | 467.52' | 0°    | 0"        | 15" RCP B WALL | 19.5"   | Hole 22   | 22"  | 22.854"   | -2.25" | 0"     |
| Invert 2 | 467.52' | 260°  | 131.625"  | 15" RCP B WALL | 19.5"   | Hole 22   | 22"  | 22.854"   | -2.25" | 0"     |
| Invert 3 |         |       |           |                |         |           |      |           |        |        |
| Invert 4 |         |       |           |                |         |           |      |           |        |        |
| Invert 5 |         |       |           |                |         |           |      |           |        |        |
| Invert 6 |         |       |           |                |         |           |      |           |        |        |
| Invert 7 |         |       |           |                |         |           |      |           |        |        |
| Invert 8 |         |       |           |                |         |           |      |           |        |        |

RIGHT-SIDE UP VIEW (int. dimensions)

UPSIDE-DOWN VIEW (int. dimensions)

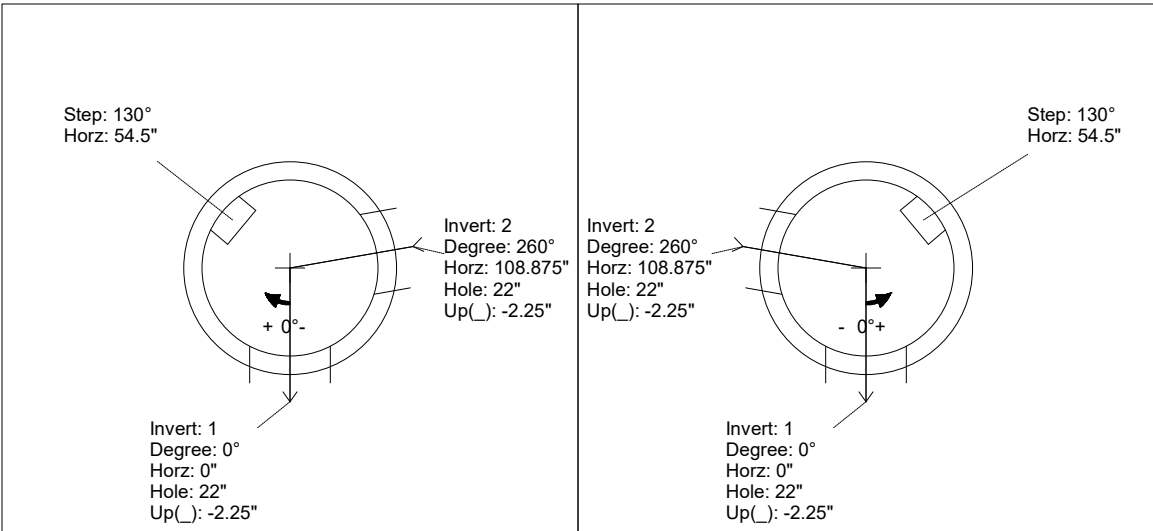
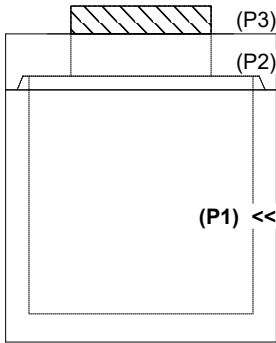

INSIDE WALL DIMENSIONS

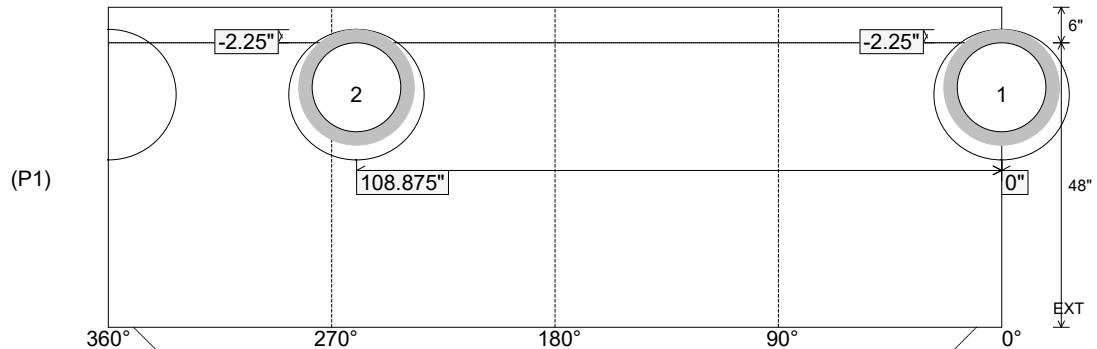

Coating (Int):  
 Coating (Ext):

Seam Up: Tongue  
 Seam Dn: n/a

Wall Thickness: 5"  
 Floor Height: 6"

Height (Int): 48"  
 Height (Ext): 54"

Weight (Net): 4354 lb  
 Volume (Net): 1.11cu.yd