

Job Name: 23-2792 - Teal Dr. Development  
 Job Location: Gallatin, TN  
 Contractor: Stewart Richey

Plant: 100  
 3/25/2026 1:41:38 PM

Tech: J. Horsley - F  
 PC: C. Goff



**Structure ID: STM-D3**

**P1 MH048BAVF**

**MH BASE Custom Ht F/n**

- P3) 30" x 30" - CASTING HEIGHT - 4"
- P2) 48" - MH FLAT TOP w/30"x30" Hole F/F - 7"
- P1) 48" - MH BASE Custom Ht F/n - 37"
- 1) CASTING - JBS 4315 F/G
- 1) 48" - Conseal CS-102 1.00"
- 1) 30" x 30" - Conseal CS-102 1.00"
- 2) Hole - 32
- 3) MH Step ML-10-TDS-NCR - 10"

0 lb  
 1264 lb  
 3188 lb  
 500 lb  
 0 lb  
 0 lb  
 0 lb  
 0 lb  
 0 lb  
 Structure Total: 4952 lb

**Structure Notes:**  
 1. PER ASTM C478 SPECIFICATIONS.  
 2. CONCRETE = 4,000 PSI AT 28 DAYS.  
 3. NO INVERT CHANNEL.  
 4. CASTING BY ICAST (JBS 4315 F/G)

REINFORCING PER ASTM A615 (GRADE 60).  
 - TOP SLAB (As .62) #5 BARS AT 6" C.C.E.W..  
 - RISER/WALLS (As .12)  
 - FLOOR (As .31) #5 BARS AT 12" C.C.E.W.

Rim: 470.05' Rim to Invert: 3.77' Slack: 0.24" Sump: 3" Step Position: 255"

Position	Elev	Angle	Ext. (cw)	Pipe	Pipe OD	Connector	Hole	Horz Size	Up ( )	Offset
Invert 1	466.28'	0°	0"	24" RCP B WALL	30"	Hole 32	32"	35.027"	0"	0"
Invert 2	466.28'	150°	75.875"	24" RCP B WALL	30"	Hole 32	32"	35.027"	0"	0"
Invert 3										
Invert 4										
Invert 5										
Invert 6										
Invert 7										
Invert 8										

RIGHT-SIDE UP VIEW (int. dimensions)

UPSIDE-DOWN VIEW (int. dimensions)

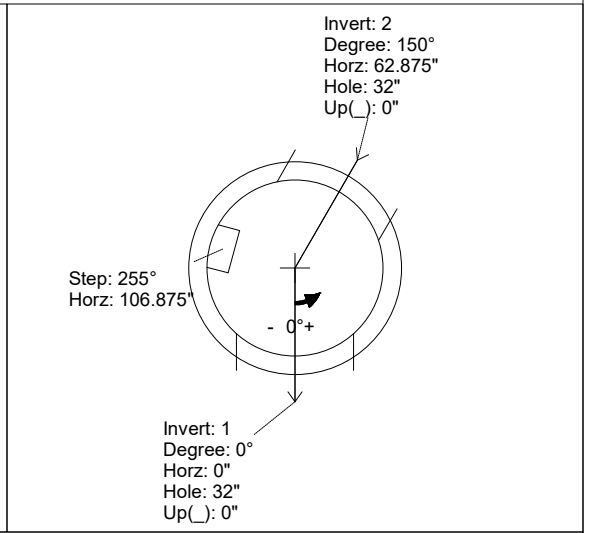
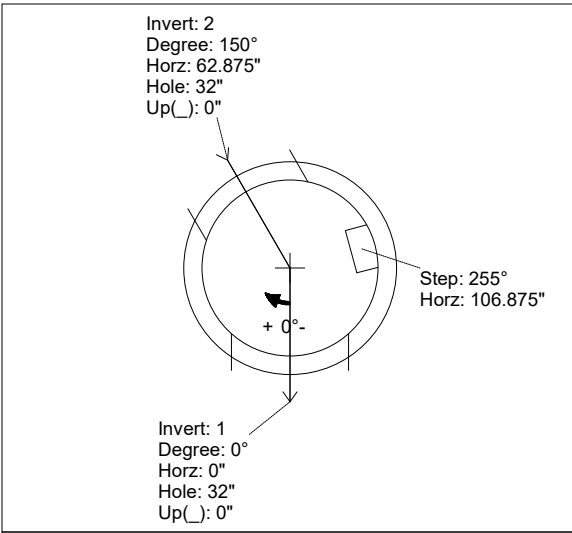
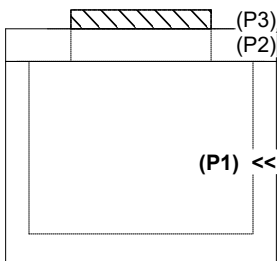

INSIDE WALL DIMENSIONS

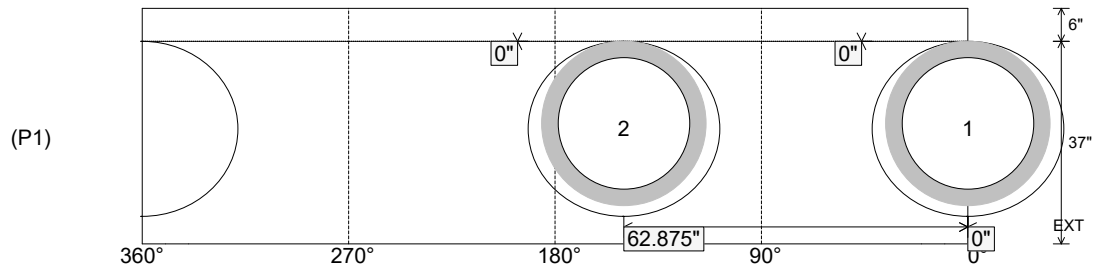

Coating (Int):  
 Coating (Ext):

Seam Up: Flat  
 Seam Dn: n/a

Wall Thickness: 5"  
 Floor Height: 6"

Height (Int): 37"  
 Height (Ext): 43"

Weight (Net): 3188 lb  
 Volume (Net): 0.81cu.yd