

Job Name: 23-2792 - Teal Dr. Development
 Job Location: Gallatin, TN
 Contractor: Stewart Richey

Plant: 100
 3/25/2026 1:41:33 PM

Tech: J. Horsley - F
 PC: C. Goff



Structure ID: STM-C3

P1 MH060BAVF

MH BASE Custom Ht T/n

- P3) 30" x 30" - CASTING HEIGHT - 6"
- P2) 60" - MH FLAT TOP w/30"x30" Hole F/G - 13"
- P1) 60" - MH BASE Custom Ht T/n - 68"
- 1) CASTING - JBS 3101 Single Set (F/G/H)
- 1) 60" - Conseal CS-102 1.00"
- 1) 30" x 30" - Conseal CS-102 1.00"
- 2) Hole - 40
- 5) MH Step ML-10-TDS-NCR - 10"

0 lb
 2400 lb
 8469 lb
 619 lb
 0 lb
 0 lb
 0 lb
 0 lb
 0 lb

Structure Total: 11487 lb

- Structure Notes:**
1. PER ASTM C478 SPECIFICATIONS.
 2. CONCRETE = 4,000 PSI AT 28 DAYS.
 3. NO INVERT CHANNEL.
 4. CASTING BY ICAST (JBS 3101 SINGLE SET (F/G/H))

REINFORCING PER ASTM A615 (GRADE 60).
 - TOP SLAB (As .62) #5 BARS AT 6" C.C.E.W..
 - RISER/WALLS (As .18)
 - FLOOR (As .37) #5 BARS AT 10" C.C.E.W.

Rim: 471.79' Rim to Invert: 6.99' Slack: 0.38" Sump: 3.5" Step Position: 90°

Position	Elev	Angle	Ext. (cw)	Pipe	Pipe OD	Connector	Hole	Horz Size	Up ()	Offset
Invert 1	464.8'	0°	0"	30" RCP B WALL	37"	Hole 40	40"	43.784"	0"	0"
Invert 2	464.8'	180°	113.125"	30" RCP B WALL	37"	Hole 40	40"	43.784"	0"	0"
Invert 3										
Invert 4										
Invert 5										
Invert 6										
Invert 7										
Invert 8										

RIGHT-SIDE UP VIEW (int. dimensions)

UPSIDE-DOWN VIEW (int. dimensions)

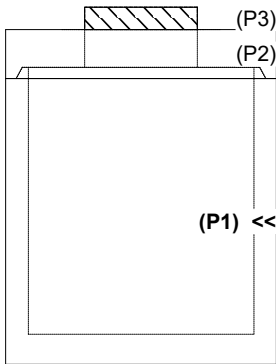
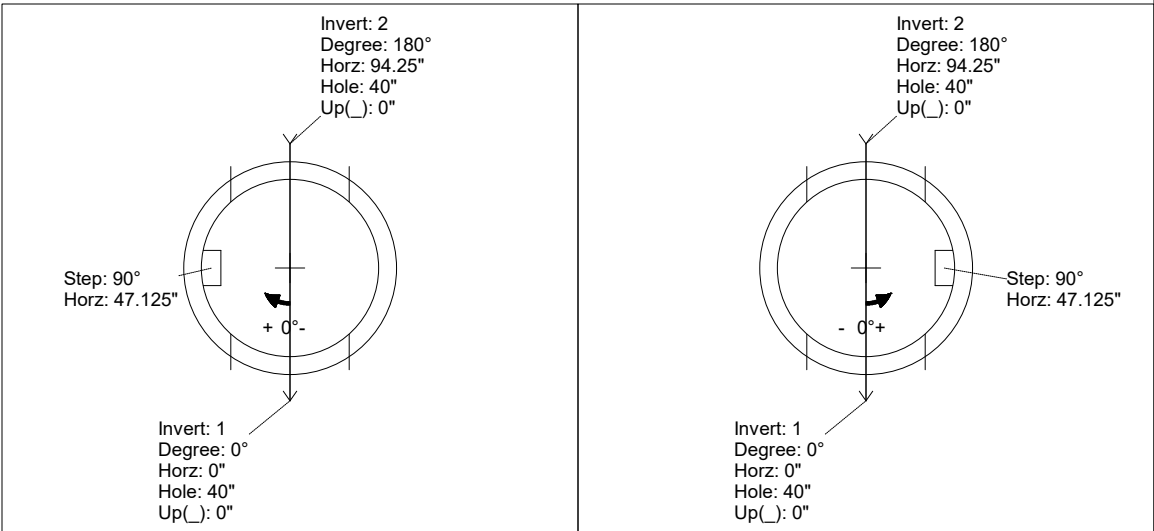

INSIDE WALL DIMENSIONS

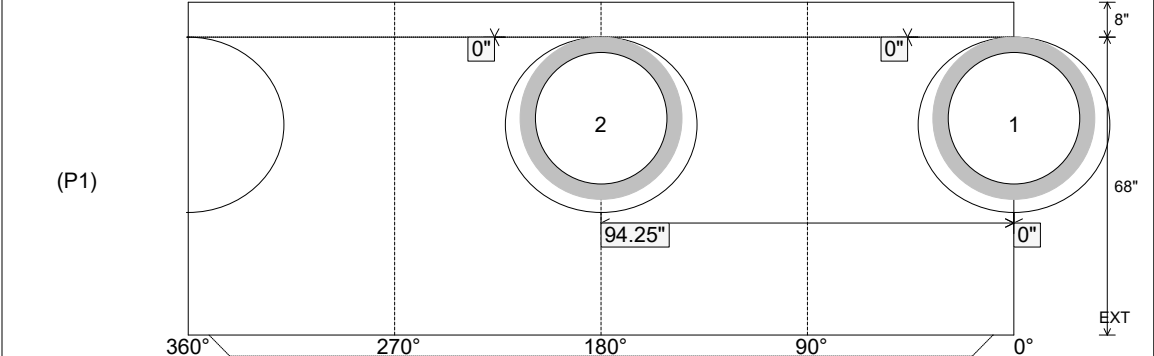

Coating (Int):
 Coating (Ext):

Seam Up: Tongue
 Seam Dn: n/a

Wall Thickness: 6"
 Floor Height: 8"

Height (Int): 68"
 Height (Ext): 76"

Weight (Net): 8469 lb
 Volume (Net): 2.16cu.yd